

# PROCEEDING

ISBN : 979 820 450-6

**INTERNATIONAL CONFERENCE**  
on Vocational Education and Training  
(ICVET) 2011

## THE ROLES OF VOCATIONAL EDUCATION IN THE PREPARATION OF PROFESSIONAL LABOR FORCE

Yogyakarta, 9 July 2011



**TECHNISCHE  
UNIVERSITÄT  
DRESDEN**



**Yogyakarta State University  
Indonesia**

# Proceeding

## International Conference on Vocational Education and Training (ICVET) 2011

---

**Publishing Institute**  
Yogyakarta State University

**Director of Publication**  
Bruri Triyono

**Chief Editor**  
Titik Sudartinah

**Secretary**  
Herlinna

**Editor**  
Eko Marpanaji

**Lay Out**  
Apri Nuryanto  
Bayu Aryoyudanta  
Anjar Fiandrianto  
Arwan Nur Ramadhan  
Agus Setiawan  
A. Anton Wahyu A.  
Lukman Rian Affandi  
Sigit Purnama

**Administrator**  
Herlinna

**Address**  
Graduate School, Yogyakarta State University

**ISBN: 979 820 450-6**

© 2011 Yogyakarta State University

All rights reserved. No part of this publication may be reproduced without the prior written permission of Yogyakarta State University

Printed in Yogyakarta  
By Yogyakarta State University  
Address : Jl. Colombo, Karangmalang, Yogyakarta 55281  
Email : [icvet@uny.ac.id](mailto:icvet@uny.ac.id) | Website : <http://icvet.uny.ac.id/>

<p>All articles in the Proceeding of International Conference on Vocational Education and Training (ICVET) 2011 are not the official opinions and standings of editors. Contents and consequences resulted from the articles are sole responsibilities of individual writers.</p>
---

## **FOREWORD**

This Proceeding compiles all papers from the invited speakers and complementary papers in International Conference on Vocational Education and Training (ICVET) 2011. The conference is organized by Graduate School and Faculty of Engineering of Yogyakarta State University in collaboration with SEAMEO Voctech on 9 July, 2011. The conference is conducted as one of the programs to celebrate the 47<sup>th</sup> Yogyakarta State University Anniversary.

The main theme of this conference is “ The Roles of Vocational Education in the Preparation of Professional Labor Force”. Three sub themes are covered in this conference: 1) Human Resources: Character Building in the Professional Development in Vocational Labor Force; 2) Organization: the Challenge of Vocational Education in the Changes of Technology; and 3) Financing and Infrastructure: the Alternatives of Vocational Education Financing.

I should apologize for the discontentment and inconvenience concerning both the conference and proceeding. I hope this proceeding will give deeper insights about vocational education and training.

Yogyakarta, 9 July 2011  
Editor

## TABLE OF CONTENTS

Title Page	
Foreword .....	iii
Table of Contents .....	iv

### PART ONE

Shaping Teaching and Learning in TVET for Developing Character Labor Force (Review Model of Project Based Laboratory) (Ana, Ade Gaffar, and Dadang Lukman Hakim).....	2
The Integrated of Character Building and Soft Skill Education to Increase Professional Human Resources in Vocational High Schools (Arik Susanti) .....	6
Developing Entrepreneurial Spirit of Vocational High School Students (Hasanah) .....	11
Re-conceptualization Vocational Education and Training In Indonesia Based on “wiwekasanga” (Putu Sudira) .....	17
Realizing Entrepreneurial Character through Curriculum Implementation in Vocational High School (Rita Patriasih, Cica Yulia, and Dian Hardijana) .....	26
Entrepreneurial Innovation in Traditional Weaving Craftsmen Designed Batik for Improving The Tourism Industry in Klaten (Sri Murni, Rahmawati, S Nurlaela, and Celviana Winidyaningrum) .....	33
Analysis of Entrepreneurship Learning to Improve Mental Entrepreneurial in Student (Suranto) .....	37
Training and Skill Development in Individual’s Productive Capacity (Muhamad Thaufiq Pinat).....	42
Integrating Virtual Training Environment Into Vocational High School To Facilitate Character Education To Deliver A Professional Workforce (Hendra Jaya) .....	46
Nation & Character Building; To Develop And Maintain The Stability Of Profesionalism To Achieve Optimum Productivity And Quality (Hamiyati).....	51
Building Character At Vocational High Schools Students For Readiness Of Work In Industry (Siti Mariah).....	58
.....	

### PART TWO

Vocational education and knowledge cooperation in professional contexts. European experiences with new technologies (Thomas Köhler).....	67
Transforming Technical And Vocational Education And Training (Tvet) By Addressing The 21st Century Issues And Challenges (Paryono).....	71
Incorporating Character Building And Development Of English Proficiency For Vocational School Students Grade X Majoring At Official Administration (Agustina Ari Wisudawati) .....	79
Principal’s Entrepreneur Leadership Model for Stakeholders Fidelity, Loyalty, Commitment, and Participation Enhancement on Vocational Schools Educations Development (Ahmad Dardiri) .....	85
Multi-connection Phone-based Mobile Internet to Support E-learning and ICT Literacy for Rural Community (Eko Marpanaji, Herman Dwi Surjono, Suprpto, and Kadarisman Tejo Yuwono) .....	91
Self-Directed Professional Development Approach: An Alternative to Enhance Vocational Teacher’s Character (Istanto Wahyu Djatmiko) .....	97
Developing the Competence of Graduates through the Implementation of a Cooperative and Interactive Program between Vocational Education and Industrial World (Janulis P. Purba and Ganti Depari) .....	102

Technical and Vocational Education Programs and Projects in Bangladesh Aiming Human Resource Development (Mahmud Al Haq Patwary) .....	107
Contribution of Mechanical Aptitude, Intrinsic Motivation, and Career Guidance to The Study Results of Light Vehicle Technical Skills Competency (Mukhidin and Heri Susanto) .....	112
Enhancing The Quality of Learning Basic Mathematic Approach for Problem Based Learning through Constructivistic In Hospitality Department (Neneng Siti Silfi Ambarwati) .....	119
Application of Assessment of Learning (AfL) to Improve Students' Self-Assesment and Technical Skills in Vocational Education and Training Program ( Sudyatno ) .....	124
Enhancing the teaching quality by implementating Instructional Design in Vocational Education (M Bruri Triyono).....	129
The mapping of Vocational High School's Profiles in Western Indonesia (Nizwardi Jalinus, Ganefri, Syahril).....	135
Study on Performance Appraisal Method of Vocational Education Teachers using PROMETHEE II (Handaru Jati).....	139
Catching Up With The Technological Progress In the Surveying and Mapping Workplace By Intensifying School-Industry Partnership (Sunar Rohmadi).....	145
Development Of Students' Metacognition at The Industrial Electronics Vocational Program In Vocational High Schools (Purnamawati).....	152
The Development of Self - Directed Learning in TVET to Prepare for a Productive Workforce (Isma Widiaty, Antelas Eka W, and Liunir Z).....	158
Analysis Of Hazards Control And Condition In Workshops/Laboratories For Ensuring Work Health And Safety In Vocational High Schools (Putut Hargiyarto) .....	162

### **PART THREE**

Educational Infrastructure And Workforce Development In Tourism And Hospitality Industry: The Case Of Thailand (Chanin Yoopetch).....	170
The CNC Simulator as Teaching and Training Aid of CNC Programming (Bambang Setiyo Hari Purwoko) .....	179
Bench Vice Production Line as an industrial model in Politeknik Manufaktur Bandung (Gamawan Ananto and Albertus B. Setiawan) .....	184
Conventional to Virtual Laboratory in Vocational Education (Bernardus Sentot Wijanarko) .....	187
The Production Unit Organizational Structure for Vocational High School in the Form of "Koperasi": Dream or Solution? (Mila Mumpuni & Widarto).....	191
The Entrepreneurship Training Model for Bamboo Waste Handycraft Product with Batik Design for School Dropouts in Klaten District, Indonesia (Rahmawati, Anastasia Riani, Asri Laksmi Riani).....	195
Managing Research And Development Organization In Vocational Higher Education (Ediana Sutjiredjeki, Katharina Priyatiningsih, and Nani Yuningsih) .....	201
Alternatives Financing Model for Vocational High Schools Field of Civil Engineering Study Program (Machmud Sugandi) .....	205

# PART ONE

Human Resources: Character Building in  
the Professional Development in  
Vocational Labor Force

# SHAPING TEACHING AND LEARNING IN TVET FOR DEVELOPING CHARACTER LABOR FORCE (REVIEW MODEL OF PROJECT BASED LABORATORY)

Ana, Ade Gaffar & Dadang Lukman Hakim

ana\_syarief@yahoo.co.id

## Abstract

Lecturers should perform a variety of innovations for practical activities to be an interesting challenge and motivate students. Routine procedures implementing the standards in the learning laboratory practicum should be changed so that students and faculty got a challenge in carrying out laboratory activities. The ability to innovate teaching and learning will have positive impact for student learning outcomes. Lectures ready critical can be a model for students to address their performance by doing a variety of innovations like the case of teachers. As a new approach to learning, project-based laboratory potential to improve learning practices in technological and vocational education. This learning approach has great potential to make the learning experience interesting and meaningful for students to enter employment. Project-based laboratory applied to develop the competence of company workers, trainees become more active in their learning, and many skills in the workplace who successfully built the project in its class, such as skill building team, cooperative decision-making, problem-solving group, and the management team. Skills are of great value in the workplace and that is a difficult skill that is taught through traditional learning. Refers to the success some colleges implement project-based learning laboratory at the School of Electrical and Information Engineering University of Sydney Department of Electronic Engineering Lunghwa University in Taiwan and the School of Electrical and Information Engineering University of South Australia, the impact on development the character students as prospective employees. This paper presents the study of innovation using project-based learning laboratory as an effort to sharpen the character of TVET students as future workers.

**Keywords:** Project based laboratory

## 1. Introduction

As an institution, Lembaga Pendidik dan Tenaga Kependidikan (LPTK), plays a vital role in building qualified learning system and building the culture of quality in this institution's learning system. Changes that occur rapidly caused today's learning quality to be different with the past's, even be expired in the future's. Therefore, the effort in improving the learning quality in LPTK will not ever stop.

Today's learning quality guidance in university level forces LPTK to be responsible for the education in the institution. LPTK has been criticized for it is separated from knowledge development source center. Therefore, the quality and relevance of LPTK has been perceived as insufficient [1]. Aside from that, programs in LPTK are reputed to be least relevance with the need of work field and the quality of the graduates is least suitable with the required skill. In the specific vocational education, the very important issue is about the incapability of LPTK graduates in performing their skill in real life [2]. It is because the quality of the graduates which is far from the market demand and the unsuitability between the graduates supply and the demand.

The very important problem that has to be solved is about how the learning performance as the

implementation of competence-based curriculum in university can be appropriate with the demand from society especially from the work fields, businesses or industries. It is believed that the future's characteristic of work field demand high level thinking skill, problem solving and collaborative working skill. A study shows that nowadays, companies from over the world want the university or school graduates to be able to improve communicative, team work and problem solving skill [3]. Considering that the future's work field will be dynamic, one's ability to construct and adopt knowledge, attitude and skills which are suitable with the experience and to be able to work in any context, will become a very important skill.

In this global era, complex tasks which will be faced in industrial and business world can only be completed by the vocational graduates which are ready to be developed, adaptive, and able to work in a team and individually. Therefore, university students are expected to play bigger role in deciding their learning objectives, to be active in exploring ideas and knowledge. They are expected not only to comprehend the culture of verbalism-formality, but also to explore the phenomena deeper in order to seek needed information through learning process, so they will acquire skill in their major.

Practical learning activity in laboratorium is a part of TVET curriculum. According the result of the pre-observation toward all practical learning activity in laboratorium, the procedure in conducting the practical learning activity is oftenly generalized, for example: the university students work in group, learn the practicum regulation, do certain testing, analize the result and make practicum report. That kind of pattern makes the students bored and unchallenged. The lecturer is suggested to design several inovations to make the practicum becomes an interesting challenge and motivates students. In this paper, the writer would like to share ideas in developing learning activity in TVET through inovated project based laboratory learning. The learning inovation which will be shared is expected to help the graduates of TVET to be manpowers which has suitable characteristic with the wrok field.

## 2. Discussion

The lecturers are expected to try several innovations so the practicum becomes an interesting challenge and motivates the students. The current practicum procedure should be modified so the students and the lecturers may face challenge in conducting the laboratorial activity. The lecturers' ability in designing learning innovation may give positive impact to the students learning. Every criticism from the lecturer is expected to be a model for the students in responding the lecturers' innovation.

As a new learning approach, the laboratory-based project is potential to fix learning practice in vocational and technological educations. This approach has big possibility to create interesting and meaningful learning experience before entering the job. According to Gaer's experience [4] in project-based learning, skills that is emphasize on is developing the company employer's competence, improving the trainees to be more active and developing skills that is build in the classroom project, for example: team building skill, cooperative decision making skill, group problem solving skill and team management skill. Those skills are valued greatly in the work place and are skills that difficult to be taught through traditional learning.

Project-based laboratory learning is a learning approach adopted from project-based laboratory. Project-based laboratory is seen as a learning model for vocational and technological education in responding issues in vocational and technological education quality improvement and big changes happened in the work field. Project-based laboratory is a learning model which focuses on the central principals and concepts of certain subject, involving the students in solving problem activity and the other meaningful tasks, gives the students to work independently and reduces valuable and

realistic learning products [5]. Unlike the traditional learning models which have isolated short duration class practicum and teacher-centered learning activity; project-based laboratory model emphasize on relative, holistic-interdisciplinary, students-centered and integrated learning.

According to Alamaki [6], the project has to be conducted collaboratively, innovatively, uniquely, and focused on problem solving related to students' life or the local industry and the society needs. This learning type has a big potency in making the more interesting and meaningful learning experience for adult learners such as university students, whether they are learning in a university or transitional training before entering the job [4]. In project-based laboratory the students are motivated to be more active in their learning. This learning method enables the instructor to supervise behind the students, so they can be initiative. This learning method also enables the instructor to give ease and to evaluate the meaningfulness and the application of the project in daily life. The product that is produced by the students during the project, shows authentic result which can be assessed by the teachers or the instructors. Therefore, in project-based learning laboratory, the lecturers or the instructors act passively and directly train, assist, facilitate and understand the students.

Dealing with an under-staffed PBL laboratory is not an easy task; instructors have to think in advance which strategies are efficient in handling teaching and learning activities, taking into account that they have such a large number of students. In small-scale laboratories this is not usually a big issue, as instructors manage a small number of working teams and their dedication to them can be quite intensive. In the past few years we have designed and implemented a set of strategies and tools to be able to deal with our PBL laboratories efficiently (according to Guarasa, et all, 2005) [7]:

1. *Strategies for the design of efficient practical documentation*: The new PBL approach has increased the complexity of the laboratory assignment, so that the traditional stand-alone laboratory assignment document is not enough in order to maximize student productivity. Our proposal involves:
  - a. *A very detailed assignment document*,
  - b. *A textbook*, updated yearly and plenty of general information about practical details on the design, implementation and testing.
  - c. *A Frequently Asked Questions* system, where the students can get information on practical issues closely related to the specific assignment of the course.
2. *Strategies for the teaching sessions*: In spite of the detailed documentation provided, the complexity of the PBL assignment makes some lectures necessary (no matter how long the



- documentation). We have evaluated two approaches:
- a. A detailed initial lecture: At the beginning of the course, instructors give a lecture that describes the whole system thoroughly.
  - b. Intermediate lectures: In every laboratory session, instructors give an initial brief lecture describing the main issues related to the subsystems that should be developed in this session, according to the proposed timetable.
3. *Strategies and tools for student progress monitoring*: A large number of enrolled students makes it more difficult to carry out a detailed progress monitoring of the course. In order to facilitate the progress monitoring process and to automate its analysis, we have designed and developed a tool for annotating the development stage the students have reached at any time. By comparing this information to the proposed timetable, the tool can detect major differences between current progress and the planned schedule. With the information gathered by the tool, we can estimate accurate statistics on the students' progress and identify possible problems in the planned schedule or unforeseeable difficulties in the laboratory assignment. The granularity of the reports is also adjustable, so that you can track the overall progress, specific workgroups or even selections of workgroups. Another way of keeping track of the students' progress is by means of requesting intermediate progress reports from the students (which can include performance measurements, design schematics, source code, etc.). In order to facilitate the reports management by instructors, we have developed a tool that allows the students to submit their reports.
4. *Strategies for guiding the advising sessions*: In a PBL course, advising students is probably the main task of the instructors. We can define two major instruction strategies: *polling* (the instructor talks to each team orderly on a one to one basis) and *interruption-based* (the instructor answers students' question as they arise). In PBL course with a high student-to-faculty ratio, the polling strategy has serious drawbacks: the instructors spend most of their advising time in polling and there is hardly no time for urgent questions. Because of the complexity of the system (different problems for different teams), if the instructor does not assist the students at these times, they may not be able to succeed.
5. *Strategies for efficient and exhaustive evaluation*: The work of students in PBL laboratories, because of its practical complex projects, it is rather difficult to grade. We may assume that the development of a fully working

prototype can guarantee that students have learnt the key points that make engineering projects successful. However, as PBL is more a process than a final result, we must look at the process, not just the final system.

In a study about effective employer [8], it is found a finding that strengthens the constructivism learning theory in vocational education. The study concluded that an effective employer has to: (1) be able to simplify the tasks, use effective shortcut and find certain strategy in order to optimize the effort in completing the task, (2) has certain flexible strategy and be able to re-organize the task to be suitable with the current asset, (3) do collaboration with partners and customers in order to develop new possibilities and find alternative solutions, (4) continually develop his competence, (5) want to change and improve himself, avoid fixed procedure. Therefore, constructivism learning theory sees the learners in an authentic context so the authentic task can be a part of educational practice as modification.

This project-based learning's effectiveness is supported by findings which prove that this learning can improve certain competence, such as academic achievement, high-level thinking ability and critical thinking ability. The learning also may improve problem solving ability and develop creativity, strengthen independence and ability to see something from better perspective, develop understanding about learning material, develop positive thinking behavior toward the subject, build more positive and supportive relationship with partners, improve communication skill and improve learning motivation [9].

Pan, et al [9], one of the researchers who studied the effectiveness of PBL laboratory, focus on project-based electronics manufacturing laboratory course for lower-division engineering students. He found that:

1. This project provides a good challenge through having to learn new subject matter and having to critically think through the issues that arose throughout the process. Also, it tests your patience, and your ability to follow instructions. These are great characteristics that will serve as a great tool for yourself and will carry through in the future when working for your future employer.
2. "Overall, this was a very educational experience. I feel that the laboratory component of this class, although very rigorous, supported the concepts presented in the class very well. Throughout the project, every aspect of the electronics manufacturing process was new to me, and I feel that I now have intimate knowledge of the art. From soldering, to etching, to board design, I felt that I truly experienced Cal Poly's 'learn by doing' philosophy."

According to the characteristic of laboratory project-based learning, it can be concluded that this learning has similarity with vocational education innovation concept, especially in these cases: (1) the learners gain the basic sciences which is useful for solving the problem related to his major, (2) the learners actively and independently learn the integrated and relevance teaching material which is usually called student-centered learning, (3) the learners are able to think critically and develop their initiation. Therefore, the application of this learning model in vocational education create opportunity in improving the learning process, learning innovation, and preparing graduates whose skill is suitable with the characteristic of the work field.

### 3. Conclusion

Shaping teaching learning in TVET through innovation learning as PBL laboratory to develop the competence of company workers, trainees become more active in their learning, and many skills in the workplace who successfully built the project in its class, such as skill building team, cooperative decision-making, problem-solving group, and the management team. Through project-based laboratory, students not only learn technical skills, but also develop their project management and communication skills.

### REFERENCES

- [1] DitjenDikt. (2005). *Peningkatan Kualitas Pembelajaran*. Jakarta : Ditjen Pendidikan Tinggi. Direktorat Pendidikan Tenaga Kependidikan dan Ketenagaan Perguruan Tinggi.
- [2] WahyuNurharjadmo. (2008). Evaluasi Implementasi Kebijakan Pendidikan Sistem Ganda di Sekolah Kejuruan. *Jurnal Spirit Publik* Volume 4, Nomor 2 halaman 215-228 Oktober 2008.
- [3] Jaques, D.(2000). *“Learning in Groups (3<sup>rd</sup> ed.)”*. London: Kogan Page.
- [4] Gaer, S. (1998). *What is Project-Based Learning?*. Diambil pada tanggal 7 Maret 2008 dari <http://members.aol.com/CulebraMom/pblprt.html>
- [5] Buck Institute for Education (BIE). (1999). *Project-Based Learning*. Diambil pada tanggal 19 September 2008 dari: <http://www.bgsu.edu/organizations/etl/proj.html>.
- [6] Alamaki, A. (1999). Current Trends in Technology Education in Finland. *The Journal of Technology Studies*. Tersedia di : Digital Library and Archives.
- [7] Guarasa, Marcias J. et.all (2005). *Tools and Strategies for Improving PBL Laboratory Courses with a High Student-to-Faculty Ratio*. 35th ASEE/IEEE Frontiers in Education Conference, October 19 – 22, 2005, Indianapolis, IN.
- [8] Sukamto. (2001). *Perubahan Karakteristik Dunia Kerjadan Revitalisasi Pembelajaran dalam Kurikulum Pendidikan Kejuruan*. Pidato Pengukuhan Guru Besar dalam Pendidikan Kejuruan Pada Fakultas Teknik Universitas Negeri Yogyakarta.
- [9] Ana. (2008). Project Based Learning: Alternative of Teaching and Learning Model for Pre- service Teacher Education in TVET. *International Journal of Education* Vol.2 No.2, May 2008
- [10] Pan, Jianbiao. et.all (2008). *A Project-Based Electronics Manufacturing Laboratory Course For Lower-Division Engineering Students*. American Society for Engineering Education.

# THE INTEGRATED OF CHARACTER BUILDING AND SOFT SKILL EDUCATION TO INCREASE PROFESSIONAL HUMAN RESOURCES IN VOCATIONAL HIGH SCHOOLS

**Arik Susanti**

arik.susanti@gmail.com

## Abstract

Today the world of education is decreasing. This is signed by the existence of robbery, sexual harassment, and fighting between the students. The education sector plays an important role to form the learner's character and behavior.

To achieve educational goals, it is required the teachers' readiness. Teachers are required to create a more pleasant learning environment, mutual respect, shared responsibility, and independent. It is hoped that the learners can acquire skills, knowledge, and adequate attitude to prepare their future life.

It is known that character education is based on moral values and national culture. Moreover, it is also based on moral behavior or affective domains in the learning process. If it is connected, character education is related to soft skills education. The concept of soft skills is the development of the concept of emotional intelligence, that is intrapersonal and interpersonal skills. Emotional intelligence and character education for the students are expected to be integrated with a variety of subjects. It is more efficient and effective to continue the sustainability and excellence in the future nation. The effective learning method will produce successful students. They are always creative, innovative, humble, positive thinking, and able to communicate. The teacher should assess not only the cognitive but also the affection and psychomotor aspect. By knowing and understanding, it is hoped that the learners can implement it in their life, inside or outside school. Finally, the national goal of our country can be achieved and all the society can live welfare and prosperously.

**Keywords:** character building, Soft skills, human resources, vocational school.

---

## 1. Introduction

Entering the 21st century, the world of education faces three major challenges. First, as a result of the economic crisis, the education is required to maintain the results of educational development which has been achieved. Second, to anticipate globalization era, education is required to prepare human resources competent in order to compete in the global marketplace. Third, in line with the decentralization it is necessary to change and adjust to the national education system to realize a more democratic educational process, take into account the diversity of needs regional circumstances and learners, and encourage community participation.

The world of education today declines. This is evidenced by mass cheating in the National Exam by elementary students, a high school girl who becomes a pimp for a her teacher. Federal Bureau of Investigation (FBI) says there are about 84,000 women who reported rape victims in one year. In Indonesia, cases of rape was ranked number 2 after the assassination (Darwin, 2000). Meanwhile, the Foundation for Consumer Child Care (BROTHER) during 2000 recorded 90 cases of sexually experienced by the children of Surakarta and rape

cases that have reached 18 people (Suara Merdeka, 2001). The conditions is mentioned above, it is alarming and endangering the life of the nation and state. In this regard, the education sector plays a centrist in the formation of character and behavior of students. It is according to National Education System Number 20 year 2003 Article 3 which reads

"National education serves to develop skills and form the character and civilization of the nation's dignity in the framework of the intellectual life of the nation, aims at developing students' potential to become a man of faith, and fear of the Almighty God, noble, healthy, knowledgeable, capable, creative, independent and become citizens of a democratic and responsible "

What it is mandated by the Law on National Education System (National Education Law) above, it is in line with the vision of national development priorities 2009-2014 to implement the 15 priorities, one of which is the improvement the quality of education, infrastructure, teacher welfare and free education for poor children.

In the perspective of formal education is required readiness and ability of schools to manage

education and cooperate with public schools as well as the readiness of teachers who are able to plan learning with a variety of approaches, models, strategies and effective methods according to the vision and mission of each school. In designing and implementing learning, teachers are required to create a learning environment (psychological and physical) that is more fun, mutual respect, shared responsibility, honest, brave, helpful, efficient and independent. It is hoped that they can acquire skills, knowledge, and adequate attitude for the preparation of his future life. To foster polite attitude of life, it is not enough to explain the lesson theoretically, but it is needed explanation by example and action. The theory explained by the teachers will be less meaningful than the attitude, example and action. Because of that, the teachers' behavior within and outside the classroom has become the center of attention, the ideal image and idol of the students. The teachers should emit the attitude and behavior that was exemplary.

In addition, the teachers should always enhance their skills and ability in educating to increase the students' interest in learning to achieve goals. The teachers, as the classroom management, means the controlling the direction of teaching and learning process. This means that students are not learning objects of teaching, but as a subject that can develop their personal potential through conscious effort in teaching and learning process. The teachers must teach based on the student centered learning.

Teachers should support and ensure the success of the learning process. Besides, they must motivate the students. They must be active and creative in the process of teaching learning. It is hoped that the students can study well. Education and public awareness about the educational character has become one of the nation program of government. With the educational national character, the process of the teaching learning will be based on moral values and national culture. Therefore, teachers must identify themselves with the values and practices of moral principles, which means that teachers are always inspired and based on moral values. Character education demands on the nation's moral behavior or affective domains of learning. If it is connected with the theory of education, character education is related with soft skills education.

It is showed that 60 percent of a person's success in life is influenced by soft skills such as ability to work in collaboration, communicate clearly and others. While the cognitive competencies affects only about 30 percent. With the development of soft skills, learners have the life skills to compete in the workforce and become more independent.

The purpose of this article is to determine: (1) the relationship between soft skills and character

education, (2) The importance of developing soft skills and character education for students and (3) strategies for developing soft skills and character education in learning.

## 2. DISCUSSION

### 2.1. Relationship Between Soft Skill and Character Education

There are many skill in curriculum, namely hard skills, soft skills, and life skills. Hard skills is general knowledge, specialized, technology, and design models. While soft skills is related to communication skills, teamwork, creativity, initiative, and emotional skills. (Wakiran, 2009). The term soft skills is related to EQ (Emotional Quotient). It is a set of personality traits, social graces, communication, language, habits, personality, friendliness, and optimism. Someone who has a EQ (soft skills) can obtain success in the organization or in the community of the association. They can relate to each other in order to make relationship with their friends in their school. So that soft skills includes a group of personality traits, language skills to form the values and attitudes. Learners who have soft skills are able to do the job with full responsibility. In general, learners will have the ability to read or type a letter. It is very necessary in the working world.

Soft skills are divided into two, they are intrapersonal and interpersonal skills. Intrapersonal skills include: self-awareness (self-confident, self assessment, trait and preference, emotional awareness) and self skill (improvement, self control, trust, worthiness, time / source management, conscience). While interpersonal skills include social awareness (political awareness, developing others, leveraging diversity, service orientation, empathy, and social skills (leadership, influence, communication, management conflict, cooperation, team work, synergy) (Daniel: 1995)

The learners are expected to have emotional intelligence (soft skill). It can be obtained if the teachers integrate it into various subjects. According to KTSP, various subjects are integrated in a single theme, known as thematic. Hopefully, the students can develop themselves through self-development that has been poured in the curriculum. Thus, soft skills can be developed through the curriculum.

Humans as social beings produce thinking systems, values, morals, norms, and beliefs. Conversely, when humans interact with them and the natural life, it is governed by a system of human thought, values, morals, norms, and beliefs that have been produced. When human life is continually evolving, it is true that social system, economic system, belief system, science, technology, and art developed. Education is a planned effort to develop students' potential, so they have a system of thought, values, morals, and

beliefs to pass and develop their life of the present and future.

Character is defined as character, morals, or personality that is formed from the internalization of various virtues which is believed and used as a basis for perspective, thinking, and acting. Virtue consists of a number of values, morals, and norms, such as honest, courageous act, trustworthy, and respectful to others. Interaction with others cultivate one's community character and national character. Therefore, the development of national character can only be done through the development of one's individual character. However, humans who live in particular social and cultural environment can develop their character. It can only be done in the certain environment. It means the development of culture and national character can only be done in an educational process which does not release students from the social environment, culture, and national culture.

Social and cultural environment in our nation is Pancasila. It means the character of the nation's education should be based on the values of Pancasila. In other words, educating the nation's culture and character is to develop the values of Pancasila. All the students' behavior must respect them. It is known that education is a conscious and systematic effort to develop students' potential. It is also a business community and the nation in preparing young people for the continuity of community life and better future of the nation. The sustainability is characterized by the inheritance of culture and character that has been owned by the community and nation. Therefore, education is the process of inheritance of culture and national character for the younger generation and also the process of developing the culture and character of the nation to increase the quality of future life in communities and nations. In the process of cultural and national character education, students actively develop their own potentials, do their internalization, and appreciation of values into their personalities in the community. It can develop a more prosperous society, and a dignified life of the nation.

Soft skills and character education must go hand in hand so that the learners can be successful men. If we hear stories of successful people, they have tips that refers to three things, such as creative and innovative, humble, positive thinking, living in a harmonious family, focus, and able to communicate. In other words, the key success is dominated by the soft skills and character education implemented optimally that will get successful learners.

This is in line with the concept of vocational education that produces professionals skilled workforce that is creative and innovative, humble, always positive thinking, and able to

communicate. If all workers in Indonesia have a personality like that, it is believed there is no longer corruption in Indonesia.

## **2.2. The Importance of the Development Soft Skills and Character Education Toward The Students**

Berthhall (Diknas, 2008) states that the soft skills are personal and interpersonal behaviors that can develop human performance (through training, teamwork, initiative and decision making. Soft skill is basic capital to develop students' personality. It is important to develop soft skills and life skills for students, because many graduate schools are not able to apply their knowledge in society. This is because the school only to teach input, process and output aspects while the students come out unnoticed. As it is known that out come of the students is one of the measure of successfull school (Kresnayana Yahya, 2001). It will be better that the schools should teach the soft skills toward the learners. Soft skills are things that are smooth, and covers the skills of psychological, emotional and spiritual. According to Krishna (2001) soft skill is an important science.

Work World believes that superior human resources are those that do not only have the hard skills but also soft skills. The result of the research at Harvard University American States suggests that a person's success is determined not only by the knowledge and technical skills (hard skills), but also determined the ability to cultivate self and others (soft skills).The study also reveals, success is determined only about 20% by the hard skills and the remaining 80% by soft skills. The fact shows that education in Indonesia gives a larger portion in hard skills than soft skill.

The fact shows that soft skills would be an urgent need in education. The teachers should provide soft skills in the learning process. To achieve that goals, it is necessary to implement some ways, namely, learning to know, learning to do, learning to live together, and learning to be. Therefore, Krishna (2001) suggests that learning does not only teach on theory but also the practices. Supposedly, the teacher takes the learner into the world of real, it is not just theory. It is known that there are many college graduates are unemployed. It is caused the graduated students are unable to apply knowledge in the real life in society. Most of them just want to be government civilization. They will do many efforts to make their dreams come true. If they have soft skill, they can create a job by themselves. They usually think creatively and analytically. In addition they will also have a confident attitude, the concept of thinking and high ambition to get a succeed.

There are three aspects to develop soft skills. First, it is the hard work. To maximize the work effort, it is needed hard work. By doing hard work,

people will be able to change his own life. Through planned education, the students will have spirit of life to work hard. The ethos of hard work needs to be introduced early in the school through various activities likes intra-and extracurricular at school.

Second, it is independence. The characteristics of independent learners is responsive, confidence and initiative. Responsive means that students are responsive to the issues themselves and the environment. As an example how they respond to the global warming crisis, they do green campus campaigns and car free day to save our world. This means that hard work will foster confidence in children. Self-reliance is also shown from the child confident.

The third, it is teamwork. Success is the fruit of togetherness. Successful completion of the task group is a classic pattern that is still relevant to display this character. Outbound training is one way to hold this character.

### **2.3. The Strategy to Implement the Soft Skills and Character Education in the Learning Process.**

Learning soft skills and character education is abstract. It is the affective (feeling) and psychomotor assessment. It makes the teachers never teach them. It is very difficult to apply it. It means the students never get the soft skills lesson in formal school. Soft skills can be learned through social interactions. The students can learn soft skills through observation of the behavior and reflection of their actions before. In other words, soft skills can be learned through the process of grinding. The concept of learning was not bound by time and place so that they can learn soft skills anytime and anywhere as long as they interact with others.

There are six categories of soft skills that can be sharpened: verbal and written communication (communication skills), organizational skills, leadership, the ability to think creatively and logically, resilience to face the pressure, teamwork and interpersonal and work ethics. The application of soft skills in everyday life can be done in many ways. One of which is in the work.

The research conducted by Daniel Golleman (1995) states that most CEOs in the world have a high Emotional Intelligence. Their ability to manage work and others become a unique incredible combination. Their emotional ability take a role to get more success than their intellectual ability. It is said that George W. Bush Jr. (President of the United States) have a great soft skills. Although most of his friends think that he is fool, he can be the president. (Widodo, 2009)

One way to teach soft skills toward the students is through character-building lesson. Character building of Education has six pillars, they are respect, responsibility, fairness, caring and

citizenship. By implementing character building in education, the teacher will give assessment not only in the cognitive aspects but also in the psychomotor effective aspects. The process of learning through character building, the students are introduced many various of good characters in their life. They must apply in their life, both at school and at home or inside and outside the school environment. Thus, the students are expected to have excellent soft skills capabilities and led to the formation of a stable individual mental life in facing the challenges ahead. By having soft skills, the student will be motivated and they will be stronger individual, that is the individual who never give up easily. To develop soft skills, the process learning developed at the school should be authentic. The students are faced with real problems so they can overcome challenges. This learning requires awareness of principals and teachers to create strategies. They also need to understand the mental attitude and how to develop them in learning. Currently, most of the principals concerned about learning, which is based on process and context of the problem in this society knock the national exams that determine students' graduation (Ahamad, 1991)

### **3. Conclusion and Suggestion**

It can be conclude that the soft skill and character education is importance toward the process of teaching learning. By implementing it, it can be created good citizens, they are creative, ambitious, analytic, and work hard. They can communicate with others, easily cooperative, responsibility, and honest. All the elements are required when they want to get job. They will create their own job and finally there are not unemployment in our country. They will do something according their competence and finally there is not corruption. All the society will live welfare.

To achieve all the nation goals, it is suggested that the teachers must be creative and motivate the students in the process of teaching learning. The teachers should teach the affection aspect toward the students. The teachers don't only teach the cognitive aspect. After they graduate from the school, they need skill that can be applied in the society, that is soft skills.

### **REFERENCES**

- [1] Ahmad, Abu & Ahmad Rohani, 1991. *Pengelolaan Pengajaran*. Jakarta: Rineka Cipta.
- [2] Adimasana, 2004. *Pendidikan Karakter Penting tapi tidak Cukup*. Insist. Jakarta: Rineka Cipta
- [3] Depdiknas, 2006. *Pengembangan Pendidikan Karakter bangsa*.

- [4] Williams, 1976. Moral development. Dlm. Adams. J.F. (pnyt.). Understanding adolescence: current developments in adolescent psychology: 176-198. Boston: Allyn and Bacon, Inc
- [5] Undang-Undang Nomor 20 Tahun 2003. Sistem Pendidikan Nasional. Bandung: Citra Umbara.
- [6] Adisusilo, 2004. Budi pekerti dan pendidikan. Kertas kerja seminar pendidikan budi pekerti, anjuran Pusat Kurikulum dan Sarana Pendidikan, Balitbang Dikbud, 2-3 Ogos 1994.
- [7] Daniel, J 1997, *Demokrasi dan Pendidikan*. Surabaya. Unesa University Press
- [8] Menteri Pendidikan Nasional 2006b, *Peraturan Menteri Pendidikan Nasional nomor 23 tahun 2006 tanggal 23 Mei 2006 tentang standar kompetensi lulusan untuk satuan pendidikan dasar dan menengah*.
- [9] *Modul Kewirausahaan 2004*, Direktorat Pengembangan Sekolah Menengah Kejuruan, Departemen Pendidikan Nasional.
- [10] Pusat Kurikulum 2007, *Naskah Akademik Kajian Kebijakan Kurikulum SMK*, Badan Penelitian dan Pengembangan Departemen Pendidikan Nasional, diakses 10/10/2009, [http://www.puskur.net/download/prod2007/45\\_Kajian%20Kebijakan%20Kurikulum%20SMK.pdf](http://www.puskur.net/download/prod2007/45_Kajian%20Kebijakan%20Kurikulum%20SMK.pdf)
- [11] Wagiran, W 2008, *The Importance of Developing Soft Skills in Preparing Vocational High School Graduates*, diakses 15/04/2010 dari tersedia pada [www.vocotech.bn](http://www.vocotech.bn).
- [12] Wijaya, TA & Mintana, A 2008, *Keterampilan Komputer dan Pengelolaan Informasi untuk SMK and MAK Kelas XII*, Erlangga, Jakarta.
- [13] Widodo, W 2009, *Tinjauan tentang Keterampilan Generik*, diakses 20/04/2010 <http://vahonov.files.wordpress.com/2009/07/keterampilan-generik.pdf>

# DEVELOPING ENTREPRENEURIAL SPIRIT OF VOCATIONAL HIGH SCHOOL STUDENTS

Hasanah, M.T.

Department of Electronic Engineering Education, faculty of Engineering Makassar State University  
hasanahunm@yahoo.com

## Abstract

Developing entrepreneurial spirit of Vocational high school (VHS) students through extracurricular entrepreneurship learning model, aims to produce quality human resources who have the entrepreneurial spirit. Formation entrepreneurial spirit of VHS students, marked by the growing attitude of self-reliance, increased entrepreneurial spirit and motivation, the development creative ideas of students', and changing the mindset to create jobs of students. This can be achieved through extracurricular entrepreneurship learning model. Through extracurricular entrepreneurship learning in vocational, self-potential students can be developed effectively. Extracurricular entrepreneurship learning model the using Contextual Teaching and Learning (CTL) approach. Contextual approach is the concept of learning that help teachers to link between what is taught with real-world situations students and encourage students to make connections between the knowledge possessed by its application in their daily lives. With that concept, the meaningful learning more for students. The learning process takes place naturally in the form of student work and experience, not a transfer of knowledge from teachers to students. Competence of indicators developed is the attitude discipline, honesty, active, creative, innovative, and productivity.

The results of the analysis of the model effectiveness show that the extracurricular entrepreneurial learning model satisfies the effectiveness criteria. The students' and teachers' responses are positive and objectively they state that the extracurricular entrepreneurship learning model is effective to develop the entrepreneurial spirit of VHS students. The extracurricular entrepreneurship learning model can function well to develop the students' entrepreneurial spirit.

**Keywords:** Development, models, entrepreneurial spirit, extracurricular.

---

## 1. INTRODUCTION

National education aims to develop the potential of learners in order to become a man of faith and piety to God Almighty, noble, healthy, knowledgeable, capable, creative, independent, and become citizens of a democratic and accountable. Based on the function and purpose of national education, it is clear that education at all level, including the Vocational high schools (VHSs) should be organized systematically to achieve that goal. This is related to the formation of entrepreneurial spirit so that students can compete in this globalization era. In the Roadmap development of Vocational High Schools (VHSs) 2010-2014 vision Directorate of Vocational High School stated that "The realization of VHSs that can produce entrepreneurial graduates who are ready to work, intelligent, competitive, and has a national identity, and able to develop local excellence and be compete in global markets".

Vocational High School as a sub-national education systems have substantial opportunities to participate in the development of the economic system that relies on the strength of the people who still grow in a difficult situation, especially if

supported by the business people are creative, innovative and have the resilience to changes. Therefore, vocational school needs to make efforts that could grow the culture, create opportunities and take advantage of the situation that there are more creative. This method can be pursued by encouraging students to utilize existing knowledge and skills to develop business, to be able to work independently in the form of small business. With built his own small business will grow a new discourse for students in developing future planning paradigm which does not only expect opportunity to work in the formal and informal, but dare to be creators of jobs.

Admittedly, short-term problems of this country are unemployment and poverty. Employment is minimal, not comparable with the quantity of school and college graduates who crowded to continue. This is the challenge ahead of VHSs. Must be able to print a true entrepreneur candidates. Vocational High Schools (VHSs) as an institution of vocational education is the beginning point as a driving force behind economic and social development in society. Vocational High Schools (VHSs) is expected to create a multiplier effect, which encourages residents as well as educational



attainment also contributes directly to economic growth. Debriefing entrepreneurship becomes important. Students are educated to be a job creator or a businessman and not just as a worker.

Vocational high school (VHS) is one of the institutions formal educational that aim to produce middle level manpower. As institutions formal education, vocational co-responsible in the revamping, enhancement of expertise and skills of students so as to produce a highly qualified workforce and trustworthy in order to enter the labor market both regional and global scale.

The substance curriculum-based of entrepreneurship, is essentially entrepreneurial in character formation of students, including curiosity, flexibility of thinking, creativity, and ability to innovate. The first to be established is `thinking` because of this flexibility that will encourage creativity. People will not be creative if his mind stiff. Creativity and innovation will not grow if the model of thought which formed the schools is a model of rigid thinking. Development of entrepreneurial spirit students can not be done only in the amount of entrepreneurship learning face to face 2 hrs / week. Therefore, the most effective learning programs to develop independence, creativity and innovation students of extracurricular entrepreneurship programs. Extracurricular activities very effectively filter out the interest and talent of the students for entrepreneurship.

The integration of subjects of entrepreneurship should be emphasized in the formation of entrepreneurial spirit embodied in the teaching materials that are being discussed. In the study of entrepreneurship, the role of teachers is very important and decisive. Invites students to practice the values of entrepreneurship, is a concrete example for teachers in implementing the values of entrepreneurship in their everyday lives. Efforts to realize the values mentioned above can be implemented through contextual learning.

Contextual approach (Contextual Teaching and Learning) is a concept of learning that help teachers to link between what is taught with real-world situations students and encourage students to make connections between the knowledge possessed by its application in their lives as family members and the community. With that concept, the learning outcomes expected to be more meaningful for students. The learning process takes place naturally in the form of student work and experience, not a transfer of knowledge from teacher to student.

Competence of indicators developed is the attitude discipline, honesty, active, creative, innovative, and productivity. The indicators here are the main materials that are developed in extracurricular entrepreneurship learning, so students are expected to have an entrepreneurial spirit.

## 2. DISCUSSION

### 2.1 Basic Concepts of Entrepreneurship Education

The term comes from the translation of entrepreneurship, which can be interpreted as "the backbone of economy", which is the nerve center of the economy or as the "tailbone of economy", namely controlling the economy of a nation.

Entrepreneurship by Suryana (2008:10) is a discipline that studies about the values, skills and behaviors in the face of life's challenges with the opportunity to acquire a variety of risks that may be encountered. Entrepreneurship is the creative ability, innovative basis, tips, and resources to find opportunities for success (Suryana, 2008:2). Furthermore Zemmerer (2008:59) says that entrepreneurship is the result of disciplined and systematic process in applying creativity and innovation to the needs and market opportunities.

While the entrepreneur is some one who is doing businesses with creative and innovative way to develop ideas and gathering resources to find opportunities and improve lives. According Hisrick & Peter (1989: 8-10) and Lambing & Kuehl, CR (2003: 23) that an entrepreneur is a pioneer in the business, someone who has a personality that is creative, innovative, productive, disciplined, risk insurer that has a vision for the future and has the advantage in achievement in the field of business.

Creative and innovative process according Suryana (2008: 3) is only done by people who have creative and innovative personality, that is, people who have the attitude and entrepreneurial behavior, characterized by: (1) Full of confidence, the indicator is fully confidence, optimistic, committed, disciplined, and responsible, (2) has the initiative, the indicator is full of energy, deft acting, and active, (3) Having a motive of achievement, the indicator is on results orientation, and insight into the future, (4) have the leadership, the indicator is able to appear trustworthy, and tough in the act, and (5) dare to take risks with the full calculation.

According to Zimmerer (2008: 6) that an entrepreneur is some one who creates a new business, with risk and uncertainty, and which aims to achieve profit and growth through the identification of opportunities and the combination of resources necessary to get the benefits. In fact enough people bring creative ideas with respect to various kinds of business, but most of them never make it happen.

Profile entrepreneurs as the elaboration of a person who has entrepreneurial spirit as expressed by Zemmerer (2008:7) that: (1) The entrepreneur has a responsibility towards the results of operations established, (2) The entrepreneur prefers intermediate risk, to take risks with the calculation mature, (3) entrepreneurs are optimistic for success., (4) the entrepreneur wants to achieve

immediate feedback, (5) entrepreneurs have a high level of energy, more energetic than others, (6) the entrepreneurial orientation of the future they saw the potential, where others see only the problems or do not see anything, (7) entrepreneurs working effectively, and (8) The entrepreneur is more concerned with achievement than an attempt to get money.

Entrepreneur basically is the soul of someone who is expressed through the attitudes and behaviors of creative and innovative ways to do activities. So it can be concluded that the entrepreneur is someone who has a soul which is expressed through the attitudes and behavior of creative and innovative ways to do activities. So a person or group of people who have the entrepreneurial spirit a superior human beings, which potentially face the future with confidence for success. In addition he has someone who has a superior private entrepreneurial spirit he must also have spiritual intelligence with emphasis on ethics and morals in the side of life.

Ciputra (2008: 61-62) says that an entrepreneur must be businessman but not every businessman is an entrepreneur. A business can be an entrepreneur because of inheritance, gift, or special facilities. Not so with an entrepreneur, he started from "zero". With a capital of a beautiful dream of the future, the power of innovation, and courage to take calculated risks he managed to give birth and raise a business. In simple language Ciputra, an "Entrepreneur and managed to turn dirt into gold". The quality of such a man would not happen overnight. A true entrepreneur who was born through a long learning process in his life, which should already be while experienced in school.

## 2.2 Competence Entrepreneurship

Competency is defined as the ability to carry out tasks in the workplace that includes the application of skills which is supported by the knowledge (cognitive) and attitude in accordance with the conditions required. According to Spencer & Spencer (1993: 9) that "A competency is underlying characteristic is individual that is causally related to criterion-referenced effective and/or superior performance in a job or situation".

Entrepreneurial competencies required are: (1) human relations competence. Entrepreneurial competencies associated with the ability to maintain, construct, develop good relationships with people, as well as parties with an interest in the company's activities, (2) technical competence. Associated with the techniques, methods, materials and labor to produce goods and services, (3) marketing competence. With regard to the ability of entrepreneurs the field of product marketing, (4) financial competence. Competence finances

management, especially looking for the cheapest sources of funding, (5) conceptual competence. Associated with the ability to make the concept of activities, events, good products, (6) decision making competence. With regard to the ability to make decisions appropriate, measurable and profitable, and (7) time management competence. Associated with the ability to time manage efficiently.

Pentti Mankine (2007: 3) describes the behavior of an active entrepreneur is someone who get things done, strategic thinking and imaginative use of resources. According to Joshua & Russell (2006: 4) that all entrepreneurs have in common is equally eager to discover and exploit profit opportunities.

Of explanation to some experts, the entrepreneurial competence is defined as the knowledge, skills and individual qualities that include attitude, motivation, personal values, and behaviors needed to carry out entrepreneurial activities that aim to produce value-added.

This extracurricular entrepreneurship learning, more emphasis to the formation personality (individual quality), that is the establishment entrepreneurial spirit (attitude, motivation, values and behavior of entrepreneurs) of Vocational High School (VHS) students.

Conceptual model of entrepreneurship learning for the establishment entrepreneurial spirit of Vocational High School (VHS) students can be described as in Figure 1.

Development of students' entrepreneurial spirit through extracurricular learning entrepreneurship aimed at changing the mindset of learners, especially those things 4H pragmatic include:

First, is the Head which is defined as thinking and learning "filled" by the knowledge of the values , spirit, soul, attitude , and behavior, so that learners have entrepreneurial ideas.

Second, is the Heart or liver which is a feeling defined, that 'filled' by the socio-economic, so that learners can feel the joys and sorrows of entrepreneurship and gain empirical experience of the entrepreneur earlier. It is expected the students began to cultivate the potential to develop anticipatory measures.

Third, is the Hand are defined as skills that must be possessed by learners to entrepreneurship. Therefore in this context of entrepreneurial learning to equip students with production techniques so that they can later be productive or produce a good product in the form of goods, services or ideas.

Fourth, the Health defined as physical health, mental and social. In this regard, learners should be provided by the techniques of the anticipation of things that may arise in the form of entrepreneurship issues, problems, and other risks as an entrepreneur.

### 2.3 Entrepreneur Life Development Process

The essence of entrepreneurship is a discipline, honest, active, creative and innovative, and productive. Therefore, the development of vocational students entrepreneurial spirit through extracurricular learning more focus into the realm of effective, namely: to develop an attitude of discipline, honest, active, creative, Innovative, and Productive. The indicators here are the main materials that are developed in extracurricular entrepreneurial learning, so students are expected to have an entrepreneurial spirit.

Mastery-oriented learning materials failing produce to active learners, creative, and innovative. Learners successfully "remember" the short term, but failed to equip students to solve problems of living in the long run. Therefore, there should be changes to a more meaningful approach to learning so as to equip students to face life problems facing the present and future. According Kunandar (2007:293) that learning a suitable approach for this is that contextual learning.

Contextual approach (Contextual Teaching and Learning or CTL) is a concept of learning that assume that children will learn better if the environment is created natural, means learning to be more meaningful if the child is "working" and "experience" for himself what he learned, not just mere "know ". Learning is not just transferring knowledge from teacher to student, but how students are able to make sense of he learned (Elaine B Johnson, 2010).

Therefore the main strategy of learning more than just results. Contextual learning was developed with the aim to equip students with the knowledge that can be applied flexibly from one problem to problem another, and from one context to another.

Empirical model for the formation of extracurricular entrepreneurship learning entrepreneurial spirit of students in vocational schools, as presented in Figure 2.

In the implementation of extracurricular entrepreneurship learning for the formation of entrepreneurial spirit of students, need to pay attention to the characteristics of contextual learning. Characteristics of contextual learning are: (a) the material is selected based on student needs, (b) students are actively involved in the learning process, (c) instructional material associated with the real life / simulation, (d) material associated with the knowledge that has been owned by students, (e ) tend to integrate multiple disciplines in accordance with the thematic, (f) the learning process contains the activities to locate, dig up information, discussion, critical thinking, working on projects and problem solving (through group work); (g) learning occurs in many places, according to context, and (h) learning outcomes measured through the implementation of authentic assessment.

By following the whole cycle as in Figure 2, foster will the spirit and motivation of students to entrepreneurship, which turn will form entrepreneurial spirit of students.

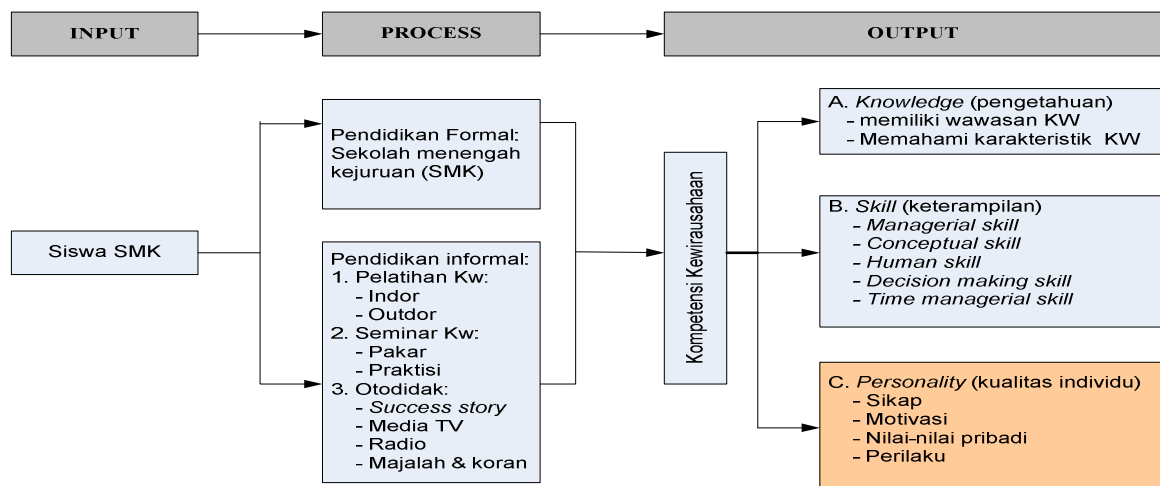

Figure 1. Conceptual model of vocational school students' entrepreneurial spirit

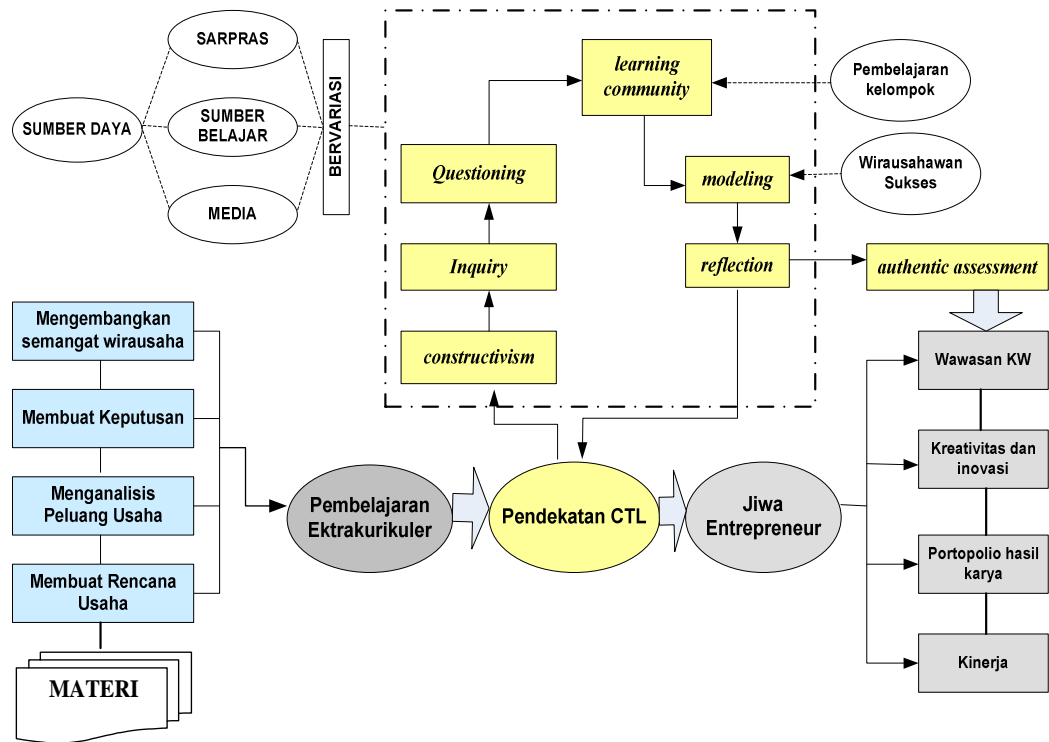

Figure 2. Empirical model Extracurricular Learning Entrepreneurship

### 3. CONCLUSION

Extracurricular entrepreneurship learning model very effectively used to develop the entrepreneurial spirit of students at the Vocational High School (VHS). This is supported by the results of research performed by the author, as follows:

1. Extracurricular entrepreneurship learning model can be used to develop the entrepreneurial spirit of students at the Vocational High School.
2. The results of the analysis of effectiveness, suggesting that extracurricular entrepreneurship learning model meet the criteria are very effective. Illustrated the effectiveness of: (a) Students demonstrate a change in attitude and behavior of entrepreneurs into a better direction, (b) Students learn entrepreneurial activity shows an increasing (c) Increased motivation and spirit of entrepreneurship for students.
3. Based on the results of the analysis of questionnaire responses of students to application of extracurricular entrepreneurship learning model at school, suggests that students are very positive response and objectively students said that extracurricular entrepreneurship learning model is effectively nurture entrepreneurial spirit in students Vocational High School.
4. Similarly, the results of the analysis of teacher responses to the application of extracurricular entrepreneurship learning model suggests that

teachers respond very positively and objectively assess the extracurricular entrepreneurship learning model is very effective to grow the entrepreneurial spirit of students at the Vocational High School.

Based on the previous discussion and results of research that has been the author, it is evident that learning is very effective extracurricular entrepreneurship foster entrepreneurial spirit of students, so it is suggested / recommended to teachers and stakeholders to consider as an extracurricular entrepreneurship activity choices of activities required for Vocational High School (VHS) students to develop the potential himself.

### REFERENCES

- [1] Ciputra. (2008). Ciputra Quantum Leap: Entrepreneurship mengubah masa depan bangsa dan masa depan anda. Jakarta: PT Alex Media Kompetindo
- [2] Depdiknas. (2003). Undang-undang RI Nomor 20, Tahun 2003, tentang Sistem Pendidikan Nasional.
- [3] Depdiknas. (2009). Roadmap pengembangan SMK 2010-2014 Direktorat Pembinaan SMK. Jakarta: Departemen Pendidikan Nasional
- [4] Hisrich, D. R. & Peter P. M. (2002). Entrepreneurship. Fifth Edition, North America: McGraw-Hill, International Edition
- [5] Johnson, Elaine B. (2010). Contextual teaching and learning: Menjadikan kegiatan belajar mengajar mengasyikkan dan bermakna (Terjemahan Setiawan Ibnu). Bandung: Kaifa (Buku asli diterbitkan tahun 2002).

- [6] Joshua, C. H., & Russell, S. Sobel (2006). Public policy and entrepreneurship school of
- [7] Kunandar. (2007). Guru Profesional: Implementasi kurikulum tingkat satuan pendidikan (KTSP) dan sukses dalam sertifikasi guru. Jakarta: PT Rajagraindo Persada.
- [8] Kuratko, Donald., & Hodgetts, Richard. (2007). Entrepreneurship: theory, process and practice, seven Edition. Canada: Thomson South-West-ern
- [9] Peggy, A. Lambing., & Kuehl, Charles. (2003). Entrepreneurship, 3<sup>rd</sup> ed. New Jersey: Prentice-Hall, Inc.
- [10] Pentti, M. (2007). Enterprise in education: Educating tomorrows entrepreneurs. small business management. Allan Gibb: Durham University.
- [11] Suryana. (2008). Kewirausahaan: Pedoman praktis, kiat dan proses menuju sukses. Jakarta: Salemba Empat
- [12] Spencer, Lyle, M., Spence, Signe, M. (1993). Competence at work: Model for superior performance. New York: John Wiley & Sons, Inc.
- [13] Zimmerer, T.W., Scarborough, N.M., & Wilson, D. (2008). Essentials of entrepreneurship and small business management (Terjemahan Deny Arnos Kwary). Jakarta : Salemba Empat (Buku asli terbit tahun 2008).

## RE-CONCEPTUALIZATION VOCATIONAL EDUCATION AND TRAINING IN INDONESIA BASED ON “WIWEKASANGA”

Dr. Putu Sudira, MP.

Faculty of Engineering Yogyakarta State Univeristy  
putupanji@uny.ac.id

### Abstract

*Wiwekasanga* is the theory of contextualized multiple intelligences illustrated as a chakras with eight leafs of intelligences which learning as a core intelligence. Eighth leaf of contextualized multiple intelligences are: (1) emotional intelligence; (2) spiritual, cultural art intelligence; (3) technological intelligence; (4) political intelligence; (5) intelligence economics; (6) kinesthetic intelligence; (7) intellectual intelligence; and (8) social-ecological intelligence. Reconceptualize vocational education and training (VET) based on *wiwekasanga* intended to develop new concepts of VET with contextualized multiple intelligences *wiwekasanga*. A new concept of VET based on *wiwekasanga* aimed developing personal of students as the core of Indonesian workers development in aspects technological, political, economic, emotional, spiritual, art and culture, kinesthetic, intellectual, and social-ecological. A new concept VET based on *wiwekasanga* intended to develop the existence of VET are socialized congruent with the vision of society in the dimensions of local, national, and global. The goal is the realization of new concepts of VET that can develop in a balanced and sustainable for social harmony and progress together, harmonious environment, cultural preservation, and effective in improving skilled educated workforce.

**Keywords:** *wiwekasanga*, vocational, reconceptualization, triplization

---

### 1. Introduction

Innovation and development quality of VET in the era of knowledge-based industries are expected to: (1) moving the students to think critically, responsible for managing the environment, information, and knowledge, (2) finalize the emotional, mental, moral and students to cooperate with each other, manage and solve the problems of life, (3) using technology (new) in an interactive, effective, and accountable, (4) foster the quality of students' individual self-intact and correct, (5) establishing a culture and entrepreneurial spirit, work culture, learning culture, and culture serve productively, (6) contextualized fit with the *desa, kala, and patra* (place, time, real conditions on the ground) (Ref. [9]; [4]; [5] [14]; [1]; [11]; [8]; [6]). VET is no longer simply be understood only as an education within the framework of the transmission of knowledge and work skills as a vehicle for economic and employment needs of the territory of a country, province, or district. VET in Indonesia should be developed as an education in order to produce culture, inculturation and acculturation process civilize the new generation of Indonesia's character. VET are required proactive and responsive to changes in economic, political, social, cultural, adopt a long-term strategy, and cultural grounding of local communities to meet their personal needs (Ref. [3]; [7]).

Globalization in the field of technological, economic, social, politics, art & culture, learning has a significant influence on innovation and development of VET. This becomes a major challenge for policy makers and decision. According to Cheng (2000) not only globalization but also the localization and individualization in the reform. They are all triplization process that can be used as a discussion in the reform and reformulate the concept of VET to the future. How to make the formulation of curriculum, teaching methods, development of facilities and so forth can be developed from the process of triplization (*triple-lization:globalization, lokalization, individualization*).

Cheng (2005) define six categories of contextualized multiple intelligences (CMI), namely: (1) technology intelligence, (2) economics intelligence, (3) social intelligence, (4) political intelligence, (5) cultural intelligence, and (6) learning intelligence. In Cheng's perspective if it is associated with the development of VET community could be viewed as an education that is contextualizedly related to the problems of technological, economic, social, political, and cultural.

Cheng view of six CMI is not enough for the Indonesian context. Sudira (2011) developed the multiple intelligences into 9 CMI, namely: (1) learning intelligence as central, (2)emotional-

spiritual intelligence, (3) socio-ecological intelligence, (4) intellectual intelligence, (5) kinesthetic intelligence; (6) economics intelligence, (7) political intelligence; (8) technology

intelligence, and (9) art-cultural intelligence. The nine intelligences are called *Wiwekasanga* like Figure 1.

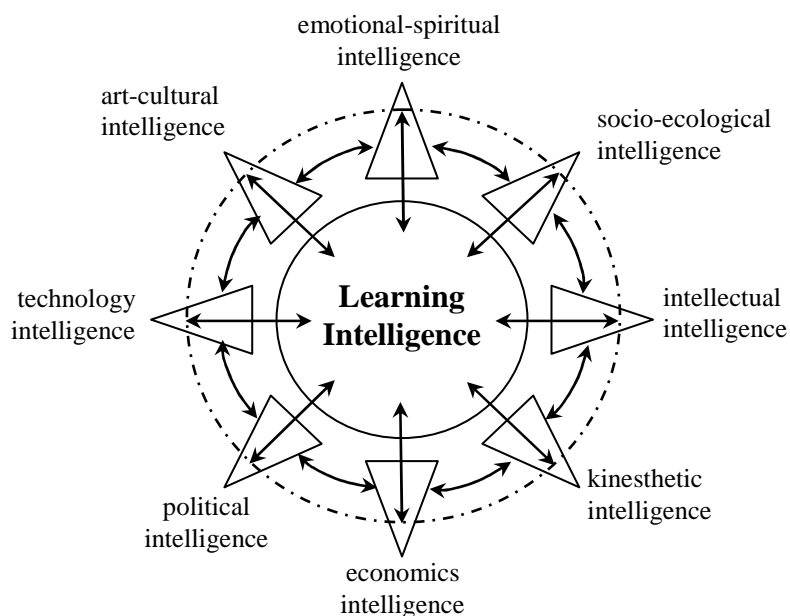

Figure 1. *Wiwikasanga* Theory (nine of contextualized intelligence)

*Wiwikasanga* theory developed from the Pentagon theory (Cheng 2000) to re-conceptualize VET as depicted in Figure 1 above. The nine CMI is interactive and relationship with each other gives reinforcement which learning intelligence as the central. VET planning should encourage and facilitate interaction among multiple intelligences and strengthening of contextualized if we want to equip people with extensive knowledge or multiple intelligences to face the challenges of a new era of global era of platinum. To increase the pace of development of CMI, development of learning intelligence plays a central role (see Figure 1).

Thus teaching and learning must provide intelligence to learn with a variety of learning experiences for students and contextualized circumstances and problems of the field. Information, educational materials must be placed within the framework of character development and ability of learners to learn how to learn systematically, creatively, critically, and cultured. To maximize your chances of developing the *Wiwikasanga* in learners then globalization, localization, and individualisasi in teaching and learning is important and necessary. The definition and impact of the nine contextualized multiple intelligences “*Wiwikasanga*” towards VET is described in Table 1 below.

Table 1. *Wiwikasanga*: 9 Contextualized Multiple Intelligences (CMI) and Impact on VET

Contextualized Multiple Intelligences	Definition of the Contextualized Multiple Intelligences	Expected Outcomes of VET
<b>Emotional-Spiritual Intelligence</b>	It refers to the ability to think, act, manage emotions and spirit to enhance the ability of sense though, <i>olah kalbu</i> , sensitivity, faith, piety, noble character.	Individuals and community leaders who are emotionally - spiritually intelligent, and thus contributing to the development of a sense though, <i>olah kalbu</i> , sensitivity, noble character, faith, piety, and spirituality.
<b>Socio-Ecological Intelligence</b>	It refers to the ability to think, act, manage socially, effecting the growth of balance and harmony between individuals. Ability to promote environmentally friendly development,	Individuals and community leaders who can contribute to the development of mutual relations, democratic, empathetic and sympathetic, uphold human rights, cheerful and confident, appreciate diversity in society and state, as

Contextualized Multiple Intelligences	Definition of the Contextualized Multiple Intelligences	Expected Outcomes of VET
	uphold the basic rights of every creature to defend itself and multiply, as a partner of the universe, is responsible for the future of the whole cosmos.	well as insightful nationality with an awareness of rights and obligations as citizens, responsibility for the future of the whole cosmos.
<b>Intellectual Intelligence</b>	It refers to the ability to think though, did, manage to secure a competency and self-reliance in science, technology, and art, critical, creative and imaginative.	Individuals and community leaders who can contribute to the development of competence and independence in science, technology, and art, critical, creative and imaginative. <span style="float: right;">Continued →</span>
<b>Kinesthetic Intelligence</b>	With regard to the ability to think, process the body, to manage themselves to achieve a healthy human being, fit, helpless-resistant, quick, skillful, and <i>trengginas</i> as the actualization of human <i>adiraga</i> .	Individuals and community leaders who can contribute to the development of health, fitness, resilience, alert, skillful, and <i>trengginas</i> as the actualization of human <i>adiraga</i> .
<b>Economics Intelligence</b>	It refers to the ability to think, act and manage economically and to optimize the use of various resources	An economically intelligent leader and citizen who can contribute to the economic development of the society
<b>Political Intelligence</b>	It refers to the ability to think, act and manage politically and to enhance win-win outcomes in situations of competing resources and interests	A politically intelligent leader and citizen who can contribute to the political development of the society
<b>Technology Intelligence</b>	It refers to the ability to think, act and manage technologically and maximize the benefits of various types of technology	A technologically intelligent leader and citizen who can contribute to the technological development of the society
<b>Art-Cultural Intelligence</b>	With regard to the ability to think, act, manage subtlety and beauty of art and culture, as well as the competence to express, using art and cultural assets and create new values.	Individuals who are intelligent in art and culture that can contribute to the development of art and culture in society.
<b>Learning Intelligence</b>	It refers to the ability to learn and think creatively and critically and to optimize the use of biological/ physiological abilities	A continuously earning leader and citizen who can contribute to the learning development of the society
<b>Contextualized Multiple Intelligences (CMI)</b>	It refers to the comprehensive ability including intellectual, technological, economic, socio-ecological, emotional-spiritual, political, art and cultural, and learning intelligences as well as intelligence transfer and creation	A CMI leader and citizen who can creatively contribute to the intellectual, technological, economic, socio-ecological, emotional-spiritual, political, art and cultural, and learning developments of the society.

Sources: Cheng, 2005

## 2. Triplization of VET

Current movement of globalization with a faster and more liquid is one aspect that can not be avoided by anyone. Interconnection network of the Internet has opened a total of boundaries of a territory. In line with the opinion of Cheng (2000) there are multiple dimensions of globalization, namely: (1) economic globalization, (2) technology globalization, (3) social globalization, (4) political globalization, (5) art and culture globalization, and (6) learning globalization in the new millennium.

Globalization refers to the transfer, adaptation, and development of values, character, knowledge, technology, and behavioral norms across countries and across societies in various parts of the world. Typical phenomena associated with globalization is the growth of global networks in the form of the internet network, world-wide communication, transfortasi, distribution technology and global digital data stream, economic, social, political, cultural, and various aspects of learning, trusts and international

competition, international cooperation, the global village, multi-cultural integration, and use of international standards and benchmarks. Implications of globalization on VET is the increasing demand for educational relevance of global development, support and initiative of various learning resources from various countries, teaching and learning.

Localization refers to the transfer, adaptation, and development of values, character, knowledge, technology, and norms of behavior or to the local context in both of the regional or national scope. Indonesia is local in the international dimension. Likewise, the provincial or local district is in a country's national outlook. Some characteristics of localization are: local networking, adaptation of technology, economic, social, cultural, artistic, political, learning initiative, knowledge, decentralized communities, local cultural development, development of local knowledge, needs and expectations of society, the involvement of regional,



inter-agency cooperation in one area, community support, kesesuain or local relevance, attention to the needs of community-based, and ethics or social norms. Implication of localization in the reform of VET is to maximize the relevance of education to regional development / regional as well as support and community resources, local cooperation, collaborative learning, teaching and schooling.

Individualization refers to the transfer, adaptation, and development of values, character, knowledge, technology, and behavioral norms to meet the needs and individual characteristics. Individulasisasi importance in human development based on the theory of motivation and needs

(Maslow, 1970; Manz, 1986; Manz & Sims, 1990; Alderfer, 1972). According Tilaar (2002) educational process is essentially a process of individualization, develop human identity. In other languages according to Suminto A. Sayuti (2005) educational process is the process of acculturation. Process related to ways of thinking and all acts that are considered true by a community, as follows planning work attempts to make it happen so that people still survive, including the process of adapting to the environment. The implications of triplisasi namely globalization, localization, and individualization in innovation and development of VET are summarized in Table 2.

Table 2. Implications Triplization on VET

Triplization	Conceptions and characteristics	Implications on VET
<b>Globalization</b>	Transfer, adaptation, and development of values, knowledge, technology and behavioral norms across countries and societies in different parts of the world: <ul style="list-style-type: none"> <li>• Global Networking</li> <li>• Economic, Political, Technological, Arts-Cultural, Emotional-Spiritual, Social-Ecological, Intellectual, Kinesthetic, and Learning Globalization.</li> <li>• Global Growth of Internet</li> <li>• International Alliances and Competitions</li> <li>• International Collaboration &amp; Exchange</li> <li>• Global Village</li> <li>• Multi-cultural Integration</li> <li>• International Standards and Benchmarks</li> </ul>	To maximize the education relevance to global development and pool up best intellectual resources, support, and initiatives from different parts of the world for learning, teaching and schooling: e.g. <ul style="list-style-type: none"> <li>• Web-based Learning</li> <li>• International Visit/Immersion Program</li> <li>• International Exchange Program</li> <li>• Learning from Internet</li> <li>• International Partnership in Teaching and Learning at group, class, and individual levels</li> <li>• Interactions and Sharing through Video-Conferencing across Countries, Communities, Institutions, and Individuals</li> <li>• Curriculum Content on Technological, Economic, Social, Political, Cultural, and Learning Globalizations</li> </ul>
<b>Localization</b>	Transfer, adaptation, and development of related values, knowledge, technology, and behavioral norms from/to the local contexts: <ul style="list-style-type: none"> <li>• Local Networking</li> <li>• Economic, Political, Technological, Arts-Cultural, Emotional-Spiritual, Social-Ecological, Intellectual, Kinesthetic, and Learning Localization</li> <li>• Decentralization to the Local Site Level</li> <li>• Indigenous Culture</li> <li>• Community Needs and Expectations</li> <li>• Local Involvement, Collaboration and Support</li> <li>• Local Relevance and Legitimacy</li> <li>• Community-based Needs and Characteristics</li> <li>• Social Norms and Ethos</li> </ul>	To maximize the education relevance to local developments and bring in community support and resources, local partnership, and collaboration in learning, teaching and schooling: e.g. <ul style="list-style-type: none"> <li>• Community Involvement</li> <li>• Public-Institutional Collaboration</li> <li>• Institutional-based Management &amp; Accountability/School-based Management</li> <li>• Inter-institutional Collaboration</li> <li>• Community-related Curriculum</li> <li>• Curriculum Content on Technological, Economic, Social, Political, Cultural, and Learning Localizations</li> </ul>
<b>Individualization</b>	Transfer, adaptation, and development of related external values, knowledge, technology, and behavioral norms to meet individual needs and characteristics: <ul style="list-style-type: none"> <li>• Individualized Services</li> <li>• Development of Human Potential in Economic, Political, Technological, Arts-Cultural, Emotional-Spiritual, Social-Ecological, Intellectual, Kinesthetic, and Learning Aspects</li> <li>• Human Initiative and Creativity</li> <li>• Self-actualization</li> <li>• Self-managing and Self-governing</li> <li>• Special Needs</li> </ul>	To maximize motivation, human initiative, and creativity in learning, teaching and schooling: e.g. <ul style="list-style-type: none"> <li>• Individualized Educational Programs</li> <li>• Individualized Learning Targets</li> <li>• Methods, and Progress Schedules</li> <li>• Self Lifelong Learning, Self Actualizing, and Self Initiative</li> <li>• Self Managing Students and Teachers</li> <li>• Meeting Special Needs</li> <li>• Development of Contextualized Multiple Intelligences</li> </ul>

Sources: Cheng, 2005

### 3. Reconceptualization in VET

Through the concept of CMI (*wiwekasanga*) and triplization in VET, shift of the VET paradigm can be expressed as a shift from the traditional paradigm to *Wiwekasanga-Triplization* paradigm. Between the two paradigms there are two very different things about the future of vocational education. In the new paradigm, the future of VET is assumed to have a thorough globalization is the globalization of Economic, Political, Technological, Arts-Cultural, Emotional-Spiritual, Social-Ecological, Intellectual, Kinesthetic, and Learning. Despite having a thorough globalization, local values remain in use as the base and root development footing. Pearls of wisdom and excellence of local Indonesia, which has high relevance to globalization rather should be developed as a contribution to the global life. The goal of VET in order to become part of local and global communities. In the *Wiwekasanga* theory

society has considered moving towards multiple intelligence community capable of providing the necessary knowledge and intelligence. Instead of the traditional paradigm educational environment primary that is characterized by the needs of local communities, the changes are relatively slow with a modest uncertainty and complexity. Educational institutions and educational systems must be assumed to be relatively stable and unchanged. Education reform is limited to the skin surface or just as a reaction to increasing demands of public accountability and the attention surrounding communities. From this paradigm the purpose of education is to equip learners with the necessary skills and knowledge to live in the local community alone. Table 3 shows the paradigm shift from traditional vocational education to the paradigm triplisasi.

Table 3. Paradigm shift in VET Context and Purpose of Education

New Paradigm <i>Wiwekasanga-Triplization</i>	Tradisional Paradigm
<b>Contexts of Education</b>	
<ul style="list-style-type: none"> <li>• <b>Triplization:</b> Education environment is characterized by globalization, localization, and individualization</li> <li>• <b>Past Changing</b></li> <li>• <b>Disappearing Boundary</b></li> <li>• <b>Continuous Development:</b> Continuous education reform and development are inevitable due to various local and global challenges</li> </ul>	<ul style="list-style-type: none"> <li>• <b>Local Needs:</b> Education environment is mainly characterized by the needs of local community</li> <li>• <b>Slowly Changing</b></li> <li>• <b>Stable Boundary</b></li> <li>• <b>Limited Reform:</b> Limited and superficial education reforms due to the public accountability and local concern</li> </ul>
<b>Purpose of Education</b>	
<ul style="list-style-type: none"> <li>• <b>Develop CMI Leaders and Citizens:</b> To support students to become CMI leaders and citizens who will be engaged in lifelong learning and will creatively contribute to building up a CMI society and a CMI global village</li> </ul>	<ul style="list-style-type: none"> <li>• <b>Equip Citizens with Knowledge and Skills:</b> To equip students with the necessary skills and knowledge to survive in a local community or to support the development of a society particularly in the economic and social aspects at a certain stage</li> </ul>

Sources: Cheng, 2005

### 4. Reconceptualization in VET Learning

In the new paradigm *wiwekasanga* and triplisasi, learning must be an individual, local/national, global as Table 4. The individualization of learning, the learner is the center of education. Learning the learner must be facilitated through the discovery of all of their needs and personality traits. Learning has also developed potential learners particularly overall of *wiwekasanga* intelligence

optimally. Learners are growing motivation to learn independently with guidance, direction, and provision of appropriate facilities. Learning is self-actualization as a process of self-reflection to find its own identity, the uniqueness of yourself as a person, the obligation of life, origin and where the future will go. Experiences is an important part of the learning process.

Table 4. Paradigm Shift in Learning of VET

Wiwekasanga-Triplization Paradigm	Traditional Paradigm
<p><b><u>Individualized Learning:</u></b></p> <ul style="list-style-type: none"> <li>• Student is the Centre of Education</li> <li>• Individualized Programs</li> <li>• Self-Learning</li> </ul>	<p><b><u>Reproduced Learning:</u></b></p> <ul style="list-style-type: none"> <li>• Student is the Follower of Teacher</li> <li>• Standard Programs</li> <li>• Absorbing Knowledge</li> </ul>

Wiwekasanga-Triplization Paradigm	Traditional Paradigm
<ul style="list-style-type: none"> <li>• Self-Actualizing Process</li> <li>• Focus on How to Learn</li> <li>• Self Rewarding</li> </ul> <p><b><u>Localized and Globalized Learning:</u></b></p> <ul style="list-style-type: none"> <li>• Multiple Sources of Learning</li> <li>• Networked Learning</li> <li>• Lifelong and Everywhere</li> <li>• Unlimited Opportunities</li> <li>• World-Class Learning</li> <li>• Local and International Outlook</li> </ul>	<ul style="list-style-type: none"> <li>• Receiving Process</li> <li>• Focus on How to Gain</li> <li>• External Rewarding</li> </ul> <p><b><u>Local and International Outlook:</u></b></p> <ul style="list-style-type: none"> <li>• Teacher-Based Learning</li> <li>• Separated Learning</li> <li>• Fixed Period and Within Institutions</li> <li>• Limited Opportunities</li> <li>• Site-Bounded Learning</li> <li>• Mainly Institution-based Experiences</li> </ul>

Sources: Cheng, 2005

Since information and knowledge accumulate and grow in extremely high speeds, it is very difficult to convey the skills and knowledge as a whole. Learners can find their own knowledge and information quickly and easily via the internet. Thus the focus of learning is learning how to learn, researching, critical thinking, and act real. Thus in order to learn it lasts and sustainable it must enjoy learning and growing sense of pride and self-esteem as learners. In local/ national and global learning, learners should be facilitated using any type of resource, support, and network that can maximize all the opportunities held during the learning process. Learners can learn from various sources, both who are in school or university and who is outside the school or university locally/ nationally and globally, not at all limited by a small number of teachers in schools or universities. Participation in locally/nationally and internationally learning programs can help learners gain insights and new experiences. Learning in some countries such as Japan, Hong Kong, France, Holland, England, America, Australia has implemented a network-based learning. Study groups and learning networks will be very easily formed through the internet. This group could include members in a single institution, cross-institutional networks in one area, or cross-country network of institutions that have a common field of study or program. The internet has provided excellent facilities to conduct the process of sharing information and share learning experiences from many different angles region can be ensured even negara. Sudah learning can occur anytime and anywhere and in the long term. Opportunities to learn almost without limit. Learners can maximize learning

opportunities through local knowledge, national, and global through the internet, web-based learning, video-conferencing, cultural exchanges, tourist visits, research collaboration, and some interactive multimedia materials. Learners can learn from teachers or guest lecturers abroad or international-class teachers, experts, couples learn, and learning materials from some developed countries in the world. Thus, their learning becomes a world-class learning.

In the traditional paradigm of thinking, learning on the learner is part of the process of reproduction or repetition of knowledge re-existing knowledge and resources in the community structure is maintained, especially in socio-economic aspects (Cheng, 2005). Education interpreted as a process in which learners and all forms of learning into reproductive structures need to find employment in the community or the nation (see Table 4). In the reproduction of learning, learners are followers of his teachers. They run educational programs are standard. Thus the students will think the same way and walked the same when in reality they have different abilities and talents at all. Self-appreciation and understanding of learning and self-esteem as learners do not exist at all. Obviously this would be very detrimental because in a short time the knowledge, skills possessed became obsolete and withered because a lot of knowledge and new skills emerge with new, more effective value of efficient and high value.

### 5. Reconceptualization in VET Teaching

In the new paradigm, teaching VET must happen Triplization of individualization, localization/ nationalization, globalization as Table 5.

Table 5. Paradigm ship in VET Teaching

Wiwekasanga-Triplisasi Paradigm	Tradisional Paradigma
<p><b><u>Individualized Teaching:</u></b></p> <ul style="list-style-type: none"> <li>• Teacher is the Facilitator or Mentor to support Students' Learning</li> <li>• CMI Teacher</li> <li>• Individualized Teaching Style</li> <li>• Arousing Curiosity</li> <li>• Facilitating Process</li> <li>• Sharing Joy</li> <li>• As Lifelong Learning</li> </ul> <p><b><u>Localized and Globalized Teaching:</u></b></p> <ul style="list-style-type: none"> <li>• Multiple Sources of Teaching</li> <li>• Networked Teaching</li> <li>• World-Class Teaching</li> <li>• Unlimited Opportunities</li> <li>• Local and International Outlook</li> <li>• As World-Class and Networked Teacher</li> </ul>	<p><b><u>Reproduced Teaching:</u></b></p> <ul style="list-style-type: none"> <li>• Teacher is the Centre of Education</li> <li>• Partially Competent Teacher</li> <li>• Standard Teaching Style</li> <li>• Transferring Knowledge</li> <li>• Delivering Process</li> <li>• Achieving Standards</li> <li>• As a Practice of Previous Knowledge</li> </ul> <p><b><u>Site-Bounded Teaching:</u></b></p> <ul style="list-style-type: none"> <li>• Site-Bounded in Teaching</li> <li>• Separated Teaching</li> <li>• Bounded Teaching</li> <li>• Limited Opportunities</li> <li>• Mainly Institutional Experiences</li> <li>• As Site-Bounded and Separated Teacher</li> </ul>

Sources: Cheng, 2005

The individualization of teaching, teaching is a process of taking initiatives, facilitating the learning process of learners on an ongoing basis, provide an opportunity to explore and self-actualization. Thus, teachers must play a role as a facilitator or a mentor who works to give support to the learning process of learners. The focus of teaching is the growth of the high curiosity of the learner and motivation to think, act, and learn.

Besides teaching must also be able to create a fun atmosphere in each process and provide a positive impact on learners. Class organization becomes very important to form a teaching that is fun and avoid the tedious teaching much less boring or intimidating. For teachers / lecturers themselves, teaching is a process of lifelong learning. A teacher / lecturer if you stop learning then he is worthy stop teaching. Conduct research, experiments, aktualiasi self, self-reflection, writing books, writing materials in order to develop professionalism as a teacher / lecturer is a must. Wiwekasanga teachers or lecturers are teachers / lecturers who can model for students to develop contextual wiwekasanga multiple intelligences. Each teacher has the potential and unique personal characteristics, so that each teacher / lecturer can be taught with different styles to maximize its contribution in teaching and education.

In the teaching of localization and globalization, the new paradigm emphasizes the one thing that teaching should be facilitated in such a way that the sources of knowledge derived from the components of local/national and global/international donation and maximize opportunities for teachers in developing learning and its contribution to the study participants learners. Many local and national knowledge with superior value that can be used as a source of learning and teaching resources. Sources of local knowledge such as the concept of *Taman Siswa* education, development concept of *Tri Hita Karana*,

Subak technology in Bali, the natural wealth in the forest and the sea, literature, art works, kerawitan and so has the value of local excellence worthy as a learning resource.

Through localization and globalization, there are a variety of teaching resources such as self-learning packages, web-based learning, bring in experts, community programs independent village, cooperation within and outside the country. Teachers can maximize the opportunities in dealing pemngajaran by maximizing learning resources from the network locally, nationally, and globally via the internet, web-based teaching, video conferencing, cross-cultural exchanges, and several sources of interactive multimedia. Instead of the traditional paradigm, teaching is seen and understood as part of the reproductive process and the recall of existing knowledge. In the reproduction of knowledge-based teaching of teachers or lecturers to be the center of education. Teachers are seen to have some technical competence, social, and professional in delivering knowledge to learners. Teachers / lecturers to teach some of the models and patterns to meet the security standards of standardized knowledge even though we know the potential, talents, and characteristics of each indivisu different learners. Their main job is to transfer some knowledge and skills to learners. Thus the teaching is often associated with discipline problems, presentation, training, and socialization processes. Teaching is also understood as the hard work of achieving external standards with a centralized authority.

In the traditional paradigm, teaching is limited to the scope of the institution whether it be school or university. The main educational institutions conducting teaching and teacher as the primary source of knowledge. Teachers / lecturers are often taught by a separate and remain responsive to the impact of teaching. They have few opportunities to support learning. Limited to standardized teaching

curriculum with textbooks and some material related to the institutions and authorities. The teachers and teaching is often stranger than the context of changing local and international community. Based on the traditional perspective, the teacher explained constrained by institutions and indivisible, and less to have views and insights globally and regionally in the developing world-class education for the participant students.

**6. Paradigm Shift in Curriculum and Pedagogy**

Traditionally, the curriculum is usually intended to meet students' needs for knowledge and skills to survive (survive) in the local community and

social development in the region together. What about triplisasi paradigm, where the objectives of the curriculum should terplisasi with the ability to build students as leaders and educated citizens *wiwakasanga* intelligence in a global village with the characteristics of growth and development aspects of technological, economic, social, political, cultural, artistic, spiritual, emotional self in atmosphere of learning without stopping. According to Cheng (2005) a paradigm shift in learning and teaching and curriculum design and a paradigm shift in pedagogy is as shown in Table 7.

Table 7. Shifting Paradigm Design Curriculum and Pedagogy

Wiwakasanga-Triplisasi Paradigm	Tradisional Paradigma
<p><b><u>New Curriculum Aims:</u></b></p> <ul style="list-style-type: none"> <li>• To develop students as CMI leaders and citizens who will creatively contribute to the formation of a CMI society and a CMI global village</li> </ul> <p><b><u>New Curriculum Characteristics:</u></b></p> <ul style="list-style-type: none"> <li>• CMI-Focused Curriculum</li> <li>• Triplized Curriculum Structure</li> <li>• World-Class and Globalized Curriculum</li> <li>• Localized Curriculum</li> <li>• Individualized Curriculum</li> </ul> <p><b><u>New Pedagogy Characteristics:</u></b></p> <ul style="list-style-type: none"> <li>• Facilitating Students' LifeLong Self-Learning</li> <li>• Multiple Sources of Learning and Teaching</li> <li>• Globally and Locally Networked Learning and Teaching</li> <li>• Worldwide Networked Pedagogical Environment</li> <li>• Boundless and Unlimited Opportunities for Learning Inside and Outside Institutions</li> <li>• Pedagogy is Based on <i>Wiwakasanga</i> Theory of CMI Development</li> </ul>	<p><b><u>Traditional Curriculum Aims</u></b></p> <ul style="list-style-type: none"> <li>• To equip students with the necessary knowledge and skills to survive in a local community or meet the manpower needs of a society</li> </ul> <p><b><u>Traditional Curriculum Characteristics:</u></b></p> <ul style="list-style-type: none"> <li>• Subject Focused Curriculum</li> <li>• Standard Subject Curriculum Structure</li> <li>• Subject-Bounded Curriculum</li> </ul> <p><b><u>Traditional Pedagogy Characteristics:</u></b></p> <ul style="list-style-type: none"> <li>• Delivering Knowledge and Skills to Students</li> <li>• Site-bounded Sources of Learning and Teaching</li> <li>• Separated Learning and Teaching</li> <li>• Classroom-Bounded Pedagogical Environment</li> <li>• Fixed Period, within Institutions, and Limited Opportunities for Learning</li> <li>• Pedagogy lacks a clear linkage with CMI development and it is often driven by the delivery of subject knowledge and external standards in examinations</li> </ul>

Sources: Cheng, 2005

In the traditional paradigm focused on the content of the curriculum design and delivery of subject knowledge in some particular field or specialization. Curriculum structure is based primarily on the knowledge and needs standardized. Curriculum structure is usually linear, its own and relies on subject matter content. What if a world-class curriculum or globalized, localized, and individualization.

On the other hand, a new paradigm focused on curriculum design for the development of CMI *wiwakasanga* students and the ability to build triplization in learning and developing themselves. Thus the design of curricula based on the characteristics of the development of CMI *wiwakasanga* and maximize opportunities for the development of individualization, localization, and globalization on the student learning experience. Curriculum structure is usually a hybrid, integrative, and interactive with the development of IT, network, local and global growth, field experience, and reality, bring different needs of students and society in the

future. The contents of the new curriculum should be world class and globally, encourage continuous world-class materials and design for learning and teaching process that maximizes its relevance to the needs and global developments as well as community development where future. Curriculum content should also be relevant to the globalization of technology, economics, social development, ecology, art and culture, and learning.

Localized curriculum consists of local sources, local materials, and concern on the suitability and the needs of the community in maximizing student learning opportunities locally. Community-based curriculum is one type of model to increase local relevance *dandukungan* field. Technological, economic, socio-ecological development, cultural arts, and learning that is local is also an important area of the contents of the new curriculum.

The individualized curriculum is designed contain or contains objectives, contents, methods, and schedules are *pleksibel* and *adaptabel* in meeting the needs of individual students, facilitate self-learning/



self-study and self-actualization them in order to optimize the potential of students to openly self-triplisasi as intelligence leaders multiple contextual and as citizens.

Characteristic shift from the traditional pedagogy that emphasizes the delivery of knowledge and skills-based subjects to a new paradigm that gives more assurance to the students to perform self-actualization, find, gain experience, enjoy, and undergo the process of self reflection. Teachers inspire and students are strongly motivated and able to reward themselves become part of the process of self-learning.

## 7. CONCLUSION

Multiple globalization makes VET society in Indonesia more diversified and multifarious and moving towards a learning CMI society. Our new generation should be prepared as a CMI *wiwekasanga* person in such a fast changing and interacting with local and global development. Reconceptualization the aims of VET should be to develop students as CMI *wiwekasanga* leaders and citizens who will creatively contribute to the formation of a CMI society and a CMI global village with multiple developments in economic, political, technological, arts-cultural, emotional-spiritual, social-ecological, intellectual, kinesthetic, and learning aspects. The new VET based-on *wiwekasanga* should facilitate the triplization of learning and make its process interactive, self-actualizing, discovery, enjoyable, and self-rewarding. VET curriculum and pedagogy should triplized and also CMI *wiwekasanga*-based, that can provide world-class learning from world class teachers, experts, peers, and learning materials from different parts of the world in any time. A new concept VET based on *wiwekasanga* intended to develop the existence of VET are socialized congruent with the vision of society in the dimensions of local, national, and global. Thi is a new concept of VET which is expected to grow in a balanced and sustainable social harmony and progress together, the harmony of the environment, cultural preservation, and effective in performing repairs terlaltih educated workforce.

## REFERENCES

- [1] Billett, S. Vocational Learning: Contributions of Wokplaces and Educational Institutions. In R. Maclean, D. Wilson, & C. Chinien (Eds.), *International Handbook of Education for the Changing World of Work, Bridging Academic and Vocational Learning*. Germany: Springer 2009, pp. 1711-1724.
- [2] Cheng, Y.C. *New Paradigm for Re-engineering Education, Globalization, Localization and Individualization*. Netherland: Springer, 2005.
- [3] Clarke, L. & Winch, C. *Vocational Education International Approaches, development and systems*. USA: Routledge, 2007.
- [4] Djohar, *Reform and the Future of Education in Indonesia* : Yogyakarta State Institute of Teacher Training, 1999
- [5] Djohar, *Local Cultural as a base Education*, Seminar paper in Kanisius Yogyakarta, 2008.
- [6] Overtoom, Christine. *Employability skills: An update*. ERIC Digest No. 220. Columbus, Ohio: ERIC Clearinghouse on Adult, Career, and Vocational Education. <http://www.ericdigests.org/2001-2/skills.htm>, 2000.
- [7] Rojewski. J.W A Conceptual Framework for Technical and Vocational Education and Training. In R. Maclean, D. Wilson, & C. Chinien (Eds.), *International Handbook of Education for the Changing World of Work, Bridging Academic and Vocational Learning* (pp. 19-40). Germany: Springer, 2009.
- [8] Rychen, D.S., Key Competencies: Overall Goals for Competence Development: An International and Interdisciplinary Perspective. In R. Maclean, D. Wilson, & C. Chinien (Eds.), *International Handbook of Education for the Changing World of Work, Bridging Academic and Vocational Learning* (pp. 2571-2584). Germany: Springer, 2009.
- [9] Sudira, P., *Praxis of the Tri Hita Karana Ideology in Competence Cultivation in Bali's Vocational High School. Dissertation*. Yogyakarta: The Graduate School, Yogyakarta State University, 2011.
- [10] Suminto, A.S., *Muatan Lokal dalam Penyelenggaraan Pendidikan*, Makalah seminar, 2005.
- [11] Tessaring, M., Anticipation of Skill Requirements: European Activities and Approaches. In R. Maclean, D. Wilson, & C. Chinien (Eds.), *International Handbook of Education for the Changing World of Work, Bridging Academic and Vocational Learning* (pp. 147-160). Germany: Springer, 2009.
- [12] Tilaar, H.A.R., *Education Culture and Civil Society Indonesia*. Bandung: PT. Remaja Rosdakarya, 1999.
- [13] Tilaar, H.A.R., *Social Change and Education, Pedagogic Transformative Introduction to Indonesia*. Jakarta: PT. Gramedia, 2002.
- [14] Wagner, T., *The Global Achievement Gap*. New York: Basic Books, 2008.

# REALIZING ENTREPRENEURIAL CHARACTER THROUGH CURRICULUM IMPLEMENTATION IN VOCATIONAL HIGH SCHOOL

Rita Patriasih<sup>1</sup>, Cica Yulia<sup>2</sup>, Dian Hardijana<sup>3</sup>

<sup>1,2</sup> Prodi Pend Tata Boga FPTK UPI, <sup>3</sup> Prodi Pend Teknik Sipil FPTK UPI  
<sup>1</sup>harpabiru@yahoo.com, <sup>2</sup>cha\_ulia@yahoo.com, <sup>3</sup>hardijana\_dian@yahoo.com

## Abstract

Seeing the present and future conditions, availability of human resources who are ready to face the global challenges and the competitiveness of nations is a vital requirement. One of them is a man who has a powerful entrepreneurial character. Entrepreneurial character, does not develop by itself but is influenced by heredity (nature) and environmental factors (nurture), one of them is in the school environment. This can be realized through self-employment in environment-based curriculum, especially vocational schools. Development of Entrepreneurship Education at its core is the development of educational methodology that aims to build the human creative spirit, innovative, sporty and entrepreneurial. The program is followed up by effort to integrate the methodology of learning, character, character education, education, creative economy, and entrepreneurship education into vocational curriculum. The essence of entrepreneurship education program is basically a learning process of planting the values of entrepreneurship through habituation and maintenance of behaviors and attitudes. Development can be done from the national level, institution, field of study up to the unit level discussion. Entrepreneurship in Vocational Curriculum Implementation can be realized in a way: include the subjects of entrepreneurship; enter entrepreneurship spirit on every subject; adjust teaching methods, and through activities extracurricular/development. Evaluation can be done through classroom assessment, basic skills test, final assessment of the educational unit, performance assessment, program assessment, assessment of field practice and implementation of business plan.

**Keywords:** Entrepreneurial Character, curriculum, Vocational High School

## 1. INTRODUCTION

Superiority of a nation linked to the ability of its competitiveness with other nations. Competitiveness refers to the ability to compete a person, group, community or nation against individuals, groups, communities, or other people related to the value of competing against its competitors. To be able to compete certainly needed the advantages, both competitive and comparative advantage. Comparative advantages related to natural resources that are available. While the competitive advantage associated with human resource capabilities. In terms of comparative advantage, the Indonesian nation has a rich natural. But for competitive advantage, a potential that can be developed, it is still lagging behind other countries.

Related to the achievement of national education goals, especially leading to the formation of characters associated with the formation of entrepreneurial attitudes and behaviors of learners, all this can't be known with certainty. This is because the measurement tends to be qualitative, and there are no national standards to evaluate it. Based on reality, according to the Indonesian Institute of Sciences (LIPI), the projected unemployment rate in 2009 rose

to 9% of the 2008 unemployment rate of 8.5%. Based on Central Bureau of Statistics (BPS), the number of unemployed in February 2008 was recorded at 9.43 million people. While the number of workforce in Indonesia in February 2008 reached 111.48 million. To reduce unemployment, need the entrepreneurial character development as early as possible, as a nation will go forward if the amount of entrepreneurial least 2% of the population. In 2007, the number of existing entrepreneur in Singapore by 7.2%, USA 2.14%, Indonesia where the population of approximately 220 million, the amount of entrepreneurial as many as 400,000 people (0.18%), which should be 4400.000 people. Means the number of entrepreneurs in Indonesia shortage of 4 million peoples. In the issue of competitiveness of a country, referring Growth Competitiveness Index Rankings 2005, Indonesian competitiveness was ranked 74th of 117 countries surveyed [1]. Human Development Index ranking (with the criteria of life expectancy, achievement of education, and own revenues) Indonesia is in position 108 (Vietnam 109) from 177 countries. Human Poverty Index rank (18.5) is in position 41 of 102 developing countries. The results

of calculations of the World Bank (December 2006) 49% (108.78 million) of the total population of Indonesia in poor condition and prone to be poor. BPS data revealed that one in 10 of the labor force status is unemployed now [2]. Yet according to research every 1 percent economic growth is only capable of creating as many as approximately 265.000 new jobs. With economic growth in Indonesia that ranged between 6 percent, then only available as much as about 1.59 million new jobs.

If we trace the causes, education became one of the main issues to be resolved seriously. High unemployment is closely related to opportunities and jobs. Availability of jobs associated with the creation of companies and industries. This is related to the quality of human resources capable of competing in meeting employment need instrumental in creating the business (goods/services). Education contributes to high quality human resources formation of character and able to become entrepreneurs reliable.

Development of entrepreneurship education is one program of the National Education Ministry which in essence is the development of educational methodology that aims to build human-spirited creative, innovative, sporty and entrepreneurial. The program is followed up by efforts to integrate the methodology of learning, character education, creative economic and entrepreneurship education into school curricula. To build an entrepreneurial spirit and reproduce entrepreneurs, the Government has issued Presidential Instruction No. 4 of 1995 on the National Movement Promoting and Cultivating Entrepreneurship. This Directive mandates to all peoples and nations of Indonesia to develop entrepreneurship programs. Furthermore, in support of the Creative Economy Development 2010-2014, the development of economic activities based on the creativity, skills and individual talents to create a creative and inventive individuals who are economically valuable and influential in the welfare of the people of Indonesia. Governments are well aware that businesses are the backbone of national economy, so it should be sought to be improved continuously. Through this movement is expected entrepreneurial culture will be part of the work ethic of the people and nation of Indonesia, so it can generate new entrepreneurs-entrepreneurs reliable, competent and independent.

Based on the facts, entrepreneurship education in Indonesia still lacks sufficient attention, either by education or society. Many educators are paying less attention to growing entrepreneurial character and behavior of students, both in vocational schools, as well as in professional education. Their orientation, generally

only in prepare the employee. For that, necessary to find the solution, how education can serve to turn people into human character or behavior and entrepreneurship. To achieve this stock of what needs to be given to students in order to have a character and a strong entrepreneurial or behavior, so that later would be human if it works in the office will be an independent labor work and if it does not work in the office will be human capable of creating jobs at least for himself.

## 2. ANALYSIS

The curriculum was developed by an educational institution will determine the output of education that has the ability in the nation's competitiveness. In this connection, it would require a curriculum model that can foster that competitiveness. The entrepreneurship based curriculum model is one way to improve the quality of human resources in order to improve the competitiveness of nations.

Based on research at Harvard University in the United States conducted by Ibrahim Ali Akbar, was a person's success is not determined solely by the knowledge and technical skills (hard skills), but more by the ability to manage ourselves and others (soft skills). This study reveals, success is determined only about 20% by the hard skills and the remaining 80% by soft skills [3]. Even the most successful people in the world can succeed because the more support the ability of soft skills than on hard skills. This suggests that the quality character education including the entrepreneurial character of learners is very important to be improved. In this regard, improving the quality of learning and other factors that affect learning outcomes needs to be done in a systematic and sustainable. Quick Study Results on entrepreneurship education at elementary and secondary education conducted by the Center for Educational Policy Research and Innovation (May 27, 2010) obtained information that entrepreneurship education will be able to generate a positive perception of the profession as an entrepreneur. This evidence is evenly found in both primaries, secondary, or high, that learners in schools that provided entrepreneurship education will provide a positive perception of entrepreneurial profession. Positive perceptions will provide a significant impact for business creation and entrepreneurship development as well as new efforts is indispensable.

### 2.1 Entrepreneurship Based Curriculum

The essence of entrepreneurship education program is basically a learning process of planting the values of entrepreneurship through habituation and maintenance of behavior and attitudes. Entrepreneurship is essentially the



nature, characteristics and nature of a person who has the will to realize innovative ideas into real-world creative[4]. The term comes from the translation of entrepreneurship "Entrepreneurship", can be interpreted as "the backbone of economy", which is the nerve center controlling the economy or the economy of a nation [5]. In epistemology, entrepreneurship is a value that is needed to start a business or a process of doing something new and different. According to Zimmerer, Thomas W, entrepreneurship is the application of creativity and innovation to solve the problem and attempt to take advantage of opportunities faced daily [6]. Entrepreneurship is a combination of creativity, risk and courage, innovation conducted by way of hard work to establish and maintain new business. Entrepreneur is the person responsible in developing, managing and measuring the risk of a business [7]. Schumpeter, as cited in Entrepreneurship By grave, says an entrepreneur is an individual who had the opportunity and created the organization to pursue (pursue opportunities) [8]. Drucker says that entrepreneurs are always looking for change, respond, and use it as an opportunity [9]. Therefore, it can be said that an entrepreneur is a person who loves change, because the changes are always opportunities there. He will always pursue these opportunities with how to structure an organization.

From some of the above understanding, it can be concluded that entrepreneurship is an ability in creative thinking and innovative behavior that basis, the resources, the driving force, the purpose of strategy, tips and processes in dealing with life's challenges. During its development, entrepreneurship is not just innate talent, or is it the practice field but is a discipline that needs to be studied. One's ability in entrepreneurship can be matured through the educational process. Someone who become entrepreneurs are those who know her potential and learn to develop their potential to seize opportunities and to organize its efforts in realizing its goals.

Person's success is not determined by the skill that belongs to, but by other factors is very important. Intelligence level accounted for only approximately 20-30 percent success, the rest is determined by the soft skills. Research NACE (National Association of Colleges and Employers) in 2005 showed labor force users need job skills in the form of 82 percent and 18 percent soft skills hard skills (high grade).

The ability of soft skills is reflected in the behavior of someone who has a personality, attitude and behavior is acceptable in public life. Consistent with the ability of soft skills,

the learners should be equipped with entrepreneurial skills education (entrepreneurship) that is reliable. Adequate knowledge and accompanied entrepreneurial aspects of practice can made the graduates have the willingness and ability, so do not feel confused when it came to entering the job market. The problem now is how to change the old mindset about the relevance of the education process to the needs of the labor market, a new mindset about the ability of schools to produce graduates job creators.

The curriculum must refer to the nation's competitiveness, as well as school vision and mission. It is in order to produce graduates who are able to enhance the competitiveness of nations, that graduates who are able to create employment opportunities. Hence, if education has a mission of carrying out educational entrepreneur, then it is proper curriculum and learning strategies change and adjustment. Seeing the characters above entrepreneurs, it seems difficult to achieve the establishment of an entrepreneur, when the learning use the "classic" strategy.

Curriculum-based entrepreneurship is a key that will be measure the success of school to create the highly competitive graduates. If a teacher wants to increase the student attitude, they should know the talents and desires of students and also values and knowledge of the students too, as well as other environment conducive to the growth of their attitudes, including political environment. Whatever the outcome, the teachers must strive to innovate in the educational process and it takes a long process to achieve a success full.

## **2.2 Entrepreneurial Character Develop through Entrepreneurial-Based Curriculum**

Entrepreneurial-Based Curriculum develop consists of several levels, start from national level, institutional level, field of study level until and discussion units level. Development of It is correlate with one of SMK mission is "Build and empower international standard of Vocational High School to develop graduates who have a national identity and competitive advantage in the national and global markets".

The aim of curriculum development institute level are to identify educational personnel in accordance with the required qualifications. Curriculum development aimed at developing of mentality and entrepreneurial character of the learners. The preparation of the components of the curriculum was conducted by the Centre for Curriculum Research and Development Ministry. It is also involves experts and practitioners of entrepreneurship in order to obtain the real

and mature understanding of the skills, motivation, and entrepreneur mentality learners.

The values developed in entrepreneurship education are the values of the characteristics of an entrepreneur. According to experts, there are many values of entrepreneurship that should be possessed by learner's and citizens of other schools. However, in the development model of academic texts were chosen several values of entrepreneurship are considered the most basic and in accordance with the developmental level of students are 17 values. Some of the values of entrepreneurship and its description that will be integrated through entrepreneurship education are as follows.

Table 1. Values and Description of Entrepreneurship Education

No	Values	Description
1.	Independent	Attitudes and behaviours that are not easy to depend on others in completing tasks
2.	Creative	Thinking and doing something to produce different ways or the result of products/ services that already exist
3.	Risk taker	The ability of someone to love the challenging job, daring and able to take the risk of work
4.	Action-oriented	Taking the initiative to act, and not to wait, before an undesirable event occurs.
5.	Leadership	Attitudes and behavior of someone who is always open to suggestions and criticism, it is easy to get along, cooperate, and direct others.
6.	Toil	Behaviors that showed serious efforts in completing the task and overcome obstacles
7.	Honest	Behavior based on efforts to make himself as someone who is always reliable in word, action, and work.
8.	Discipline	Actions that show orderly behavior and comply with various rules and regulations.
9.	Innovative	Ability to apply creativity in order to solve the problems and opportunities to enhance and enrich the lives
10.	Responsibilities	Attitudes and behavior of someone who is willing and able to carry out the duties and obligations
11.	Cooperation	Behavior based on efforts to establish relationships with others in implementing the action, and work.
12.	Unyielding	Attitudes and behavior of someone who does not easily give up to achieve a goal with a variety of alternative
13.	Commitment	Agreement on something made by someone, either to himself or others.

14.	Realistic	The ability to use facts / reality as the foundation of thinking rationally in every decision and action/ actions.
15.	Curiosity	The attitude and actions are always trying to find out in depth and extent of what is learned, seen, and heard
16.	Communicative	Actions that showed love to talk, socialize, and cooperate with others
17.	Strong motivation to succeed	The attitude and actions are always looking for the best solution

Source : The Curriculum Centre [10].

Meredith in Suprojo Pusposutardjo give characteristics of a person who has the character of entrepreneurs as people who (1) confidence, (2) task-oriented and results, (3) risk-taking, (4) spirited leadership, (5) future oriented, and (6) originality [11]. Grammatical form of entrepreneurial behavior traits appear in the table below.

Table 2. Form of Behavior from Entrepreneur Characteristic

Entrepreneur characteristic	Form of behavior
confident	1. Working confidently 2. No dependence in doing the job
Task-oriented and results	1. Satisfy the achievement needs 2. Work orientation : profit, determined and steadfast, hard work determination. 3. Initiative
Dare to take risks	1. Brave and able to take the risk 2. Liking the work challenging
spirited leadership	1. Behave as a leader who is open to suggestions and criticisms. 2. Easy to get along and work with others
Thinking toward the outcome (benefit)	1. Creative and Innovative 2. Flexible in carrying out the work 3. Having a lot of resources 4. Versatile and knowledgeable
originality	1. Look ahead thinking 2. Perspective

Source : Meredith in Suprojo Pusposutardjo [11]

## 2.3 Entrepreneurship in the School Curriculum Implementation

### 2.3.1 Entering the subjects of entrepreneurship

Entrepreneurship is not enough just to rely on innate talent, or is the practice field. Entrepreneurship is a discipline that needs to be studied. One's ability in entrepreneurship can be matured through the educational process. Entrepreneurship is also a discipline that has its

own object, namely the ability to create something new and different [4].

Scharg argued that the entrepreneur is the result of learning [12]. Although the spirit of an entrepreneur may also be obtained at birth (talent), but if not sharpened through learning and motivated in the learning process, it is difficult to be realized. To sharpen the interest and ability of entrepreneurs have grown, developed through the learning process. Herein lies the importance of education and entrepreneur in education.

Subjects or subjects of entrepreneurship today need to be given to all learners. Likewise, if possible every lesson, entered the entrepreneurial element in which are creativity, innovation, and are not afraid of risk, so that aspect of practice on the field a top priority..

Entrepreneurship aims subjects so that learners can actualize themselves in entrepreneurial behavior. Entrepreneurship course content focused on entrepreneurial behavior as an empirical phenomenon that occurs in the environment of learners. In this regard, more active learners are required to study the economic events that occurred in his neighborhood.

Entrepreneurship education can also be incorporated into the category of local content. Material values of entrepreneurial learning that goes on local content include:

- 2.3.1.1 The values of entrepreneurship are associated with what is already understood and experienced by students in everyday life, either directly or indirectly (contextual learning)
- 2.3.1.2 Giving freedom and guidance to students in understanding (conceptualization) material values of entrepreneurship is being discussed (learning achievement and constructivism concept).
- 2.3.1.3 Promote the creation of activities that allow students to work together, collaboration in understanding the values of entrepreneurship is being discussed (cooperative learning).
- 2.3.1.4 Giving students the chance to try out or apply the material learned.
- 2.3.1.5 Using a variety of media to facilitate student learning in the sharpen and understand the values of entrepreneurship that is being studied.
- 2.3.1.6 Maintaining discipline and responsibilities of students during the learning process, while avoiding activities that impact boring, loosen the spirit of learning and

ends with the disruption of activity and creativity of student learning.

2.3.1.7 Learning geared to familiarize students carefully observes the reality of life around (local, regional, national and global).

The standards of competence and basic competences of subjects Entrepreneurship serves as a reference for curriculum development. Curriculum development is basically adapted to the potentials and characteristics of each area. Entrepreneurship aims subjects so that learners can actualize themselves in entrepreneurial behavior. Entrepreneurship course content focused on entrepreneurial behavior as an empirical phenomenon that occurs in the environment of learners. In this regard, more active learners are required to study the economic events that occurred in his neighborhood.

Here is an illustration can be seen as standards of competence and basic competence in vocational Entrepreneurship Training

Table 3. Standards of Competence and basic competence in vocational Entrepreneurship Training

Competency Standard	Competency Based
Actualize the entrepreneuria l attitude and Behavior	1. Identify attitudes and behavior of entrepreneurs 2. Applying the attitudes and work behavior 3. Formulate a solution to the problem 4. Developing the entrepreneurial spirit 5. Build commitment for themselves and for others 6. Taking a business risk 7. Making decisions
Applying leadership spirit	1. Indicates unyielding and tenacious attitude 2. Conflict managing 3. Business vision and mission Building
Plane the micro business	1. Analyze business opportunities 2. Analyze aspects of business management 3. Develop a business plan
Manage the micro business	1. Preparing a business establishment 2. Calculating the risk of doing business 3. Running a small business 4. Evaluating the results of operations

Source : Entrepreneurship Syllabus of High Vocational School, 2010. [13].

Learning methods as described above that the essence of entrepreneurship educations to instill an attitude, opening insights and debriefing the experience early in the process of learning rather than memorization or cognitive target, but learned

through the cultivation of habits that should be done or do it yourself over and over again and not just only understand and experience. For that purpose, the methods used include:

- 2.3.1.1 Lecture: Used in conveying the material, concept, experiences or other information relating to the cultivation of an attitude, insight and delivery of stock of knowledge.
- 2.3.1.2 Role playing / simulation: Used in providing experience to apply the concept of entrepreneurship, including providing input on the attitudes and behaviour observations of student performance in real conditions and situations.
- 2.3.1.3 Discussion: Used in an effort together to understand a concept to learn, cooperate and respect each other and exchange ideas or experiences.
- 2.3.1.4 Assignment / project work: Used in an effort to provide early experience, foster self-confidence (Learning dare to do something in real situations) to explore alternative solutions to problems.
- 2.3.1.5 Problem Solving / Case Study: Used to deal with cases that are more specific by compare the characteristics of the problems faced by entrepreneurs who must possess as a solution.
- 2.3.1.6 Observation / Observation: Used to directly observe the object in order to obtain theoretical information of practical truth.
- 2.3.1.7 Presentation: Used in the trains uncover ideas, ideas and express themselves through discourse, speech sketches, charts, etc. Place of implementation of the learning Organization Entrepreneurship learning can be done in classrooms, halls, open spaces, such as camping and so on, because there is no limitation in determining the standard of learning process.

Aspect of evaluation is one component of the curriculum, then to evaluate the learning outcomes, may include:

- 2.3.1.1 Evaluation of Competency "A" is actualized attitudes and behaviours of entrepreneurs conducted through joint activities planned, such as: selling. In the evaluation process is not known "wrong" and "right", that there is "good" and "better".

- 2.3.1.2 Evaluation of achievement of competencies "B" is to plan the management of entrepreneur simulation, carried out by measuring the mastery of teaching materials (cognitive).

- 2.3.1.3 Evaluation of competence "C" is managing the process of truth observations and proven results in personal attitudes and behaviour.

### **2.3.2 Entering entrepreneurship spirit on each subject.**

Teachers sorting and selecting materials are most relevant to the purpose of each subject and as much as possible to give application of real case at locations (local context).

### **2.3.3 Adjusting Teaching Methods**

Teaching methods should also be adjusted from classroom learning (class room) which becomes monotonous active learning and in the field (field study).

### **2.3.4 Through the activities esktraculiculer / self-development.**

Self-development is an educational activity outside the subject as an integral part of school curriculum. Self-development activities are efforts to establish his character and personality of students committed to creativity and career development through activities such as entrepreneurship.

Entrepreneurship is one of the alternative choices of students in extra-curricular activities. In this extra-curricular entrepreneurship students will get some material including : 1) Business Management, 2) Organization, Implementation and Monitoring / Evaluation of Business; 3) Coaching Skills and Entrepreneurial Training.

Through this curriculum graduates are expected to be able to independently create jobs. New curricula or revisions of the old curriculum must involve many parties, so as to accelerate the process of verification and evaluation of stakeholders, government, schools and the world of business practitioners.

## **2.4 Evaluation**

In a detailed evaluation of learning outcomes in curriculum implementation entrepreneurial performed with 7 way : 1)the classroom assessment; 2) the basic skills test; 3)the final assessment and certification of the education unit; 4) the assessment based on ongoing performance

to achieve optimal results; 5) the assessment program; 6) the assessment of field practice and 7) the assessment of business performance running [14].

### 3. CONCLUSION

By education-based entrepreneurship then its graduates do not have to stare only work in the formal sector, such as a civil servant, worked in SOEs and the like, but have the ability to create jobs. Stock owned not only limited knowledge and skills, but also the entrepreneurial character that is built through education in schools.

The success of entrepreneurship education will reduce the problem of employment and poverty, which is a problem for the nation and the country of Indonesia. The success is largely determined by the participation of education stakeholders, such as government, business, banking and the wider community.

3.1 Education contributes to the high role in the formation of qualified human resource that can become entrepreneurs by leveraging and managing the potential for the welfare of the surrounding area when supported with appropriate curriculum.

3.2 The curriculum is made must refer to the needs of the nation's competitiveness, as well as the vision and mission schools in producing graduates.

3.3 Development of entrepreneurship in vocational-based curriculum does not only refer to the knowledge and skills but also expected to grow mentally and entrepreneurs a reliable character.

3.4 Implementation of entrepreneurship based curriculum can do ways: 1) Insert the subjects of entrepreneurship, 2) Insert a spirit-entrepreneurship on each subject, 3) Adjust teaching methods and 4) Through extracurricular activities or personal development

3.5 Evaluation of Entrepreneurial Based Curriculum learning outcomes can be done by: classroom assessment, basic skills test, final assessment of educational units, assessment based on ongoing performance, assessment programs, assessment practices and assessment of field-run business performance.

3.6 Expected by entrepreneurs based in the school curriculum, able to create a quality human resource, be ready to use force even able to create jobs.

### REFERENCES

- [1] Wasino. 2008. Locales Advantage Based Curriculum Model. <http://wasinow.wordpress.com/2008/02/18/model-kurikulum-berbasis-keunggulan-lokal/>
- [2] Central Bureau of Statistics. 2007. Summary of Meta Data Base Activities agency Statistics. Statistics Center. BPS Catalogue : 1192. Jakarta. <http://sirusa.bps.go.id/doc/metadatas2007.pdf>
- [3] Ali Ibrahim Akbar. 2009. Character Education Coaching in Middle School. <http://prabowosetiyobudi.files.wordpress.com/2011/05/panduan-karakter-smp.pdf>
- [4] Suryana. 2003. Entrepreneurship: A practical guide, tips and Process to be Success. Revised Edition Salemba Empat. Jakarta.
- [5] Santoso. 2010. Entrepreneurial Character Education in Non-formal Education Program. Non-formal Education Development Center And Informal Education Regional Iv Surabaya. <http://www.bppnfi-reg4.net/index.php/pendidikan-karakter-wirusaha.html>
- [6] Zimmerman, Thomas W. Scharborough. 2005. Introduction to entrepreneurship and Micro Business Management. 2<sup>nd</sup> edition. Prenhalindo. Jakarta.
- [7] Machfoedz, Mas'ud., & Machfoedz, M. (2005). Entrepreneurship. Metode, Management and Implementation. Yogyakarta. BPFEE.
- [8] Bygrave, W. D. 2004. The Portable MBA in Entrepreneurship: Third Edition/edited by William D. Bygrave, Andrew Zacharakis. - Ed. 3 - New Jersey : John Willey & Sons Inc.
- [9] Drucker, Peter F. Inovation and Entrepreneur : Based and Practice . Jakarta : Erlangga, 1996.
- [10] Pusat Kurikulum. 2010. Training material reinforcement learning methodology Values Based Culture to form the Nation's Competitiveness and the character. Development of entrepreneurship education. BAPPENAS. Ministry of National Education. Jakarta.
- [11] Suprodjo Pusposutardjo "Cultural Development Through Entrepreneurship Skills Course ". Papers. Delivered in a workshop Entrepreneurship Insights IKIP YO GYAKARTA on July 17-19, 1999.
- [12] Scharg, Adele F dan Robert P. Poland, 1987. A System for Teaching Business Education. New York : McGraw-Hill Book Company.
- [13] Entrepreneurship Silaby High Vocational School.
- [14] Badrun, A M. 2006. Enterpreneurship Based Curirulum. Suara Merdeka, 6 Juli 2006. Jawa Tengah
- [15] Pusat Kurikulum. 2007. Manuscript Academic Vocational Curriculum for Policy Studies. Curriculum Center. Research And Development. Ministry of National Education. Jakarta.
- [16] Zimmerman W. Thomas Et al. (1996). Entrepreneurship and The New Venture Formation. New Jersey. Prentice Hall. Inc.

# ENTREPRENEURIAL INNOVATION IN TRADITIONAL WEAVING CRAFTSMEN DESIGNED BATIK FOR IMPROVING THE TOURISM INDUSTRY IN KLATEN

Sri Murni, S.E. M.Si. Ak, Prof. Dr. Rahmawati, M.Si, Ak, Dra. Siti Nurlaela, M.Si, Ak, Celviana Winidyaningrum, SE, M.Si

Economics Faculty Sebelas Maret University Surakarta, Universitas Islam Batik Surakarta,  
STIE St. Pignatelli Surakarta

rahmaw2005@yahoo.com

## Abstract

The Target of this study is to improve skilled knowledge and attitude worker of weave fasten as that self-supporting as according to potency and also opportunity work at industrial company, which is on finally can improve the quality of its life. Special target of this study give the knowledge of entrepreneurship among worker of weave fasten so that have high job ethos and also can yield pre-eminent masterpieces capable to compete in global market. This training was funded by DIPA BLU economics Faculty UNS (Sebelas Maret University).

The implementation take place to start 16 July until 23 July 2010, what consist of three phase that is activity early stage cover preparation phase, middle phase of activity which phase execution of training and also final phase of activity covering phase handling of post training.

This training assign value added because there is skilled of batik design innovation at weave fastens affecting at make-up of production addition. The next study shall earn to measure effectiveness of "transfer training" on so that will be able to know how far done training can alter behavior of educative participant plunging in corporate world and industrial world and also trying self-supporting.

**Keywords:** designing batik, training, entrepreneurship innovative method, and weave fasten.

---

## 1. Introduction

### 1.1. Analysis of Situation

In recent, bussiness grows and changes rapidly, because human character tends to change along with individual changes from era to era. The growth also follows the growth of the human need. The changing and growing of the world mostly in knowledge and information technology.

The changing in knowledge and information technology (IPTEC) influences all of living aspects of human being. In other word, IPTEC is one of important things for our living. It is no wonder, if the expert says that kowledge is foundation for technology while technoligy is backbone of development. Mixing IPTEK and capability of human in kowlegde, and added a little of "sense of art" will create a creative industry in the world.

Central Java expand because it sucess to coordinize cities in around the area, namely are Yogyakarta, Solo, Magelang, and Sragen. The cities are well-known because batik. Meanwhile, Bali is known because of handicraft and also is supported by international network. Therefore, this devotion of society will link cities of Solo and Yogakarta.

Based on statistical data in Indonesia in 2003, total number of Small and Middle Enterprise

(SME) is 42.4 million and they gave contribution to product domestic broto (PDB) equal to 56.7%. They also contributed to export 19,4% and provided jobs to labour equal to 79 million (BPS, 2003).

Another data shows that SME could provide 99,9% jobs for people from total labours in Indonesia (Urata, 2000 as cited by Dwiriyanti, 2003). Beside that, SME can be developed in their productivity and competitiveness. They also have function to create technology, product, new service, support to economy growth, and create 750 changes and market competition (Stoner, 1995 as referred by Lupiyoadi, 2004).

Based on the fact, it can be concluded that successfulness of SME has big influence to ecomony in Indonesia. Exsistency of the SME can be used to main activator to recover economy condition in Indonesia. They also can be used as a supporting to export activities and increasing in people welfare, including the entrepreneur's welfare.

Based on the previous research in Jogjakarta (Indrarti and Langenberg, 2004) indicates that successfulness of SME is influenced by some of factors. Result of the research shows that marketing, technology, and capital influence to successfulness in bussiness positively, while legaly influences to successfulness in bussiness negatively. The other interesting finding in the

research is that educated entrepreneur (graduated from university) is less success than entrepreneur who has degree in elementary until senior high school.

Klaten Regency has 65,556 hectare consists of 26 district (kecamatan), 401 countryside (desa dan kalurahan), and 1,972,740 residents in 2007. It is an agrarian area consists of 30,779 hectares of rice field and 34,777 hectares of non-rice field.

BPS data indicates that the number of labor force in Indonesia in 2008 is 111.4 million. From the number, 9.42 million (8.48%) is unemployed who living in rural (4,186,703 or 44.4%) and urban (5,240,887 or 55.6%). While, composition of education level of the unemployed are: (1) 27.09% elementary degree; (2) 22.62% junior high school degree; (3) 25.29% high school degree; 15.37% vocational school; and (4) 9.63% diploma until undergraduate degree. In this time, impecunious resident in Indonesia is 34.96 million (15.42%) divided into two composition, resident who live in rural 22,189,122 (63%) and urban resident is 12,770,888 (37%).

Unemployment in Indonesia is caused by lag of supply and demand of labor force, lag of job seeker and competency, unskilled labour, and job fired because of global crisis.

Based on the data above, there are opportunity to academician in university to create activities to solve the problem in Indonesia, especially solving about unemployment. One of the activities is helping the society by giving skill and knowledge by training to prepare the people have ability to compete in global market labor through devotion of society.

The main problem in Klaten regency is there are a lot of poor residents. Poverty must be handled because it will be ended in disintegration and social problem. Residents in Klaten face the problem (poverty problem) because of less education, knowledge, and skill to be entrepreneur.

Activities of devotion of society by academician are done through: (1) analysis training needs; (2) training-based entrepreneurship; and (3) placement job. Objective of these activities is to transfer batik design to people who have no job through: (1) making linkage to facilitate the people to know batik design; and (2) training the people to know about practice skill for used in job opportunities whether formal or informal sector.

## 2. Objective and Benefit

- a. For The trainees  
To increase knowledge, skill, and attitude in batik design to the trainees, so they will have ability to work or be independent suitable with their potentials and job opportunities in industry, and finally it will rise quality of their life.

- b. For the society  
To create job opportunities and reduce lag of social life so that it will minimize negative impact of kerawanan social.

## Output Target

All of the trainees can make "weave fasten" designed batik.

Activities of training is designed to work in group (there are four groups).

## Method and Planning of Activities

The training activity is done through some of ways:

### Work in Group

There are 20 trainees and divided into four groups

### Andrology Approach

It is a personal approach to suit the needs and abilities of the trainee and minimalizes instructional approach.

Ratio of theory to practice is 20% vs 80%

## 3. The Activities

The content of subject consist of theory (general and supporting subject) and practice (skill). The training activity is done during a week (six times @ 100 minutes) at July, 16 until July, 23 in 2010. Allocation of the each subject are:

## 4. Result Of The Activity

1. Objective of the activity
  - a. To increase the trainee's skill in planning and managing business of batik design, so that the trainee will get income properly to their life.
  - b. To grow of entrepreneur knowledge to increase work ethos and result excellent product to compete in market.
  - c. To increase the trainee's ability to manage resources, social, culture, and environment. They also can use both of technology and design in batik handicraft.
  - d. To have ability to understand themselves, other, and environment. Beside that the trainee can work in team professionally whether in formal or informal sector.
2. Assistance Activity
  - a. Objective  
To give advocation and technical instruction especially knowledge and skill to the trainees, so they can use them in business.
  - b. Content
    - 1) Batik Design on Weave fasten
    - 2) Planning and managing entrepreneurship

- 3) Principle of Management and Bookkeeping
  - c. Trainer  
The trainers consist of:
    - 1) three academicians (lecturers) of Economic Faculty of Sebelas Maret University
    - 2) three experts
  - d. Model (Approach)  
Using participation model through full participation of the trainees. The trainees are divided into four groups and each group consists of five persons. One person becomes a leader and the others as members of the group.
  - e. Time and Place  
The training of batik design on weave fasten is done in Sumber Countryside, Trucuk District, Klaten Regency on July, 2010 through six times training and once evaluation.
3. Implementation of assistance  
The trainers team visited each group, identified the problem, and gave a solution of the problem through giving some explanations about the difficulty in weaving and batik designing, also in batik process on weave fasten.  
The team also gave instruction and guidance to get good material by giving examples of the material, applying and using the material in the production process.  
In the end of training, the team made an evaluation for the trainees. The objective of the evaluation is to know that the trainees could produce standard products. This step was used to select the product to enter the market or to select the trainees who are ready to work.  
If the result of evaluation indicated that the objective of the training was not reached, the team would extend the time of training until the trainee could produce standard products or they were ready to work.

## 5. Conclusion

1. Activity the program
  - a. Preparation Phase  
This phase consists of the process of selection and recruitment of the trainee. The selected trainee has fulfilled the stated criterion. It is done in a timely and suitable manner with the schedule in June - July, 2010.
  - b. Training Phase  
The training activity is done in July 2010. The fund is according to the budget. Based on the result of evaluation data, the trainee's ability in knowledge and skill, especially skill of Batik Design on Weave fasten, has increased significantly.

2. Institutional Benefit  
Increasing role of Economic Faculty of Sebelas Maret University in implementation of knowledge and technology to increase the quality of poor society life in rural, especially in education, economic, social, and culture.
3. Social Benefit  
The training activity gives contribution to develop and increase human resources in Sumber Countryside, Trucuk District, Klaten Regency, so the activity is going to change the society of residents to become professional entrepreneurs.
4. Economic Benefit  
This activity increases the value added of the trainee's skill, especially Batik Design on Weave fasten. The impact is increasing in the income of the residents.

## 6. Suggestion

1. Increasing input quality (society) by entering certain criteria for selection of the trainee, namely are: (1) ability of the trainee in entrepreneurship; (2) the trainee has strong willingness to become an entrepreneur of Batik Design on Weave fasten.
2. The training design is developed to participative training through adjustment of content, the trainee's needs, capacity of the trainee.
3. Developing training design model consists of training analysis, implementation, and evaluation, so that the trainees can get knowledge, skill, and new attitude, also they can implement their ability in working.

## 7. EXPECTATION

1. The training of Batik Design on Weave fasten in Sumber Countryside, Trucuk District, Klaten Regency is expected to change the trainees' attitude in working, so that the transfer of training can be done well. The transfer of training means that activities continue to implement knowledge, skill, and attitude which were gained in the training.
2. The program can replicate to residents who have not yet gotten a job or are unemployed residents, because the program pushes the resident (trainee) to work professionally.
3. It is needed to study (research) to measure the effectiveness of transfer on training, and study to identify the factors affecting the efficacy of learning.

## REFERENCE

- [1] Nusantoro, Adi, 2002, *Memberdayakan Ekonomi Rakyat Untuk Pembangunan Ekonomi Indonesia*, **Jurnal Ekonomi dan Bisnis**, UGM, Yogyakarta.
- [2] Suryana, 2001, **Kewirausahaan**, Penerbit Salemba Empat, Jakarta



- [3] Suhartono dan Raharso, 2003, Transfer Pelatihan : Faktor Apa Yang Paling Mempengaruhi, **Kajian Bisnis**, STIE Widya Wiwaha, Yogyakarta, No. 28 Januari-april 2003.
- [4] Mutis, Thoby, 1995, **Kewirausahaan Yang Berproses**, Penerbit Grasindo, Jakarta.
- [5] Usman dan Musrifah, 2003, Pengaruh Pembinaan Terhadap Produktivitas Pengrajin Dalam Upaya Meningkatkan Kinerja Keuangan , Studi Pada Industri Sulaman Tradisional Motif Aceh di Kota Banda Aceh, **Jurnal Manajemen & Bisnis Vol 5 No.3 September 2003**.
- [6] Wiklund, John, 1999, **The Sustainability of The Entrepreneurial Orientation Performance Relationship , Entrepreneurship – Theory and Practice**.

## ANALYSIS OF ENTREPRENEURSHIP LEARNING TO IMPROVE MENTAL ENTREPRENEURIAL IN STUDENT

Suranto

(Industrial Engineering Lecturer – Faculty of Engineering, UMS Solo)  
Jl. A. Yani Tromol Pos 1 Pabelan Kartasura 57102 Telephone 0271 717417  
ranto\_ums@yahoo.com

### Abstract

This study aims to know about the differences of entrepreneurial mental for students who have received entrepreneurship courses with students who have never received entrepreneurship courses. Students are said to have entrepreneurial mental if in itself has an indicator on professionals and independent businesses with the characteristics: independence of effort, management skill, the skill of thinking, innovative, creative, dare to try, never give up, the spirit of trying, trying ideas, job-oriented, dare to face the risks, responsibilities, hard work, ready to work under pressure, networking, broad thinking, self-development and work professionally.

The data collection technique used questionnaire data, interval scale, direct observation, interviews and documentation, also libraries study. The technique of data analysis used validity and reliability of the questionnaire. Data analysis with Mann Whitney test, to determine the differences of entrepreneurial mental in students, comparing who have earned and have not earned the entrepreneurship material in Informatics Engineering Department of Sainstek UIN Sunan Kalijaga Yogyakarta.

This study consist of 40 people to examine the validity and reliability of the questionnaire. The number of respondents are 80 students in accordance with the table Harry King, and also the Mann Whitney test was used to determine the differences of entrepreneurial mental in students before and after learning the entrepreneurship material. Based on the data processing with Mann Whitney test, we found the result of  $Z_{count} < Z_{table}$  ( $-2.008 < -1.965$ ) and probability  $0.021 < 0.05$ , this indicates that there is significance differences between students who have never received the course of entrepreneurship material with student who have received the course of entrepreneurship material.

**Keywords:** learning, mental, entrepreneurship.

---

### 1. INTRODUCTION

The government expects the graduates of vocational education, whether from intermediate level or from higher education are able to do their own business, do not relies on other parties. Related to this orientation, there is one of the programs from the Director General of Secondary and Vocational Education "the graduates from vocational education must become a *skipper*", it is also embodied in the national education goal that want to make a whole human being of Indonesia be able to support its own needs.

In order to achieve the educational goals, the government make a new rule, that is recommended to make the entrepreneurship course shall included in vocational education curriculum. Through the entrepreneurship course, the learners will be expected to have a strong mentality of doing business independently.

Based on data from the Central Statistics Agency (CSA), Indonesia has 113.83 million graduates that ready to work and the unemployment rate is dominated by intermediate school of vocational and Diploma of Vocational Education.

For graduates of vocational school as much as 14.59%. This figure is greater than graduates from high school as much as 14.50%. As for the diploma as much as 13.66%, it is bigger than the graduates from university (3.08%), (Central Bureau of detailed statistics: 2009)<sup>1</sup>. Therefore, development of Indonesian completely is very important. In reality, the policy and development which is not balance have been produced a lot of unemployed people. So, the entrepreneurial learning get special attention because it expected this knowledge can give the students ability to open their own jobs.

Based on that problems, researchers identified the problem that is the lack of interest and awareness of entrepreneurship among students or learners. It is approved by many graduates from higher education level has not been able to open up jobs independently and some of graduates from college choose to seek employment, that means most graduates from college just as job seekers (job seekers), rather than creators of jobs (job creators). Therefore, the formula of this study is whether some differences of entrepreneurial mental among students who have not received and the student who received the entrepreneurship courses in informatics

engineering departement, Sainstek UIN Sunan Kalijaga Yogyakarta. The place and subjects of this study were informatics engineering students at the Engineering Faculty of Sainstek UIN Sunan Kalijaga Yogyakarta. The goal of this study was to determine the differences of entrepreneurial mental among students who did not receive and has receive entrepreneurship courses in Informatics Engineering Departement, Sainstek UIN Sunan Kalijaga Yogyakarta.

## 2. THEORY

### 2.1 Definition of Entrepreneurship

Entrepreneurship is "*applying creativity and innovation to solve the problems and to exploit opportunities people face that everyday*" (Zimmerer, 1996)<sup>2</sup> that means the application of entrepreneurial creativity and innovation to solve a problem and as an attempt to take advantages of opportunities that facing everyday and this is a progressive approach. Beside of that, entrepreneurship is also the ability to be creative and innovative as a basic, tips and resources to look for opportunities to success (Suryana, 2003)<sup>3</sup>.

### 2.2 Characters of entrepreneurial

Characteristics of an entrepreneur is (Zimmerer, 1996)<sup>2</sup>: 1) *Commitment and determination*, which has the unanimous commitment and determination to devote all attention to business. 2) *Desire for responsibility*, which has a good sense of responsibility in controlling their resources and success of entrepreneurship, 3) *Opportunity Obsession*, which is always eager to always look for opportunities, 4) *tolerance for risk*, which is resistant to the risk of uncertainty, 5) *Self Confidence*, that is confident to their self, she/he tends to be optimistic and have a strong conviction with they capabilities. 6) *Creativity and flexibility*, that is inventive and flexible, 7) *Desire for immediate feedback*, which always need feedback to improve performance, 8) *High level of energy*, which has a high energy and high expectations, 9) *Motivation to excel*, which is always pushing to be excellence, 10) *Orientation to the future*, which is oriented to the towards of the future, 11) *Willigness failure to learn form*, which is always learn from failure, 12) *Leardership ability*, the ability in leadership.

### 2.3 Learning and Objectives of Entrepreneurship

According Istiningsih et al (2009)<sup>4</sup> learning is a structured combination includes the elements of human, material, facilities, equipment and procedures that affect each other to achieve the goals of learning. The term "*learning*" same with "*instruction*" or "*teaching*". Teaching means the way of teach or to teach. Thus, teaching same with

the act of teaching to learn (by students) and taught (by teachers). Teaching and learning activities is a unity of two activities in one direction.

Learning is a communicative-interactive process between study resources, teachers, and students for exchanging information. The term of "*skills*" in the "*learning of skills*" taken from the word "*skilled*" (skillful) which means proficiency in implementing and completing tasks with fixed, fast and precise. The word "fixed" implies responsive to the problems that faced from the stand point of character, shape, behavioral and systems of the object. The term "fast" refers to the ability to anticipate the rapid changes, reducing the shortage gap to the problem or objects and produce workbased on a target time of the breadth of material, or quantity in accordance with the specified target. Word "precise" means ability to act precisionly to make pleasant form of systems, shape, quality and quantity and also behavioral characteristics of the object or work. Aspects of learning include some of the following: a) Learning Strategy is a learning activity to be done for teachers and students in order to the learning objectives can be achieved effectively and efficiently. Learning strategy include the planning, it's mean that basically the strategy still a conceptual about the decisions to be taken in the implementation of learning. b) Design of learning, if learning strategies more related to general patterns and general procedures of learning activities, whereas design of learning is more consentration to planning a specific learning environment system after a particular set of learning strategies. c) Learning Method can be interpreted as the implement the plans that have been arranged in the form of concrete activities and practical to achieve the learning objectives.

The aims of learning entrepreneurship or entrepreneur (Qomarun, 2000)<sup>5</sup> has glorious aims, they are: a) Cultivating the attitude of business conduct from an early age for students, b) Instilling a spirit of independence, tough, strong, stand on its own, and dig self potential, talent, and also intelligence of the learners. c) cultivate a spirit and attitude, behavior, business skills among learners that are reliable and superior. d) To improve the professionalism of the learners themselves so they not to rely onother people and be able to dig up intelligence for the sake of prosperity of they life.

## 3. METHODOLOGY

### 3.1 Research Object

The research object in this final report takes from two objects, thera are: in informatics engineering Sainstek UIN Sunan Kalijaga Yogyakarta. Data that used in this study was primary and secondary data. Data collection methods by observation, interviews,

documentation, questionnaires and literature study. The variables in this research is the free and bound variables.

### 3.2 Data Analysis Techniques

Data analysis needs to be done in a study, in this study data analysis techniques include sampling taking techniques and a questionnaire testing through validity and reliability test and testing of hypotheses.

### 3.2.1 Population and Sample

The sampling technique that used in this study is simple random sampling. It call simple because taking the samples from the population was randomly so all populations have equal opportunity to become population sample and college students sample.

Table 1. Total Population

Respondent	Population
Student	220

(Data source :Aprilia, dkk, 2011)<sup>6</sup>

Determination of the sample using the guidelines Arikunto (2006)<sup>7</sup> concluded using the number of subjects at 100-1000 and can be taken about 10% -25% or more of the total population. Both determination of the number of samples in this

study based on Nomogram Harry King, with the percentage of population 10%, then the number of samples can be seen in table -2

Table 2. The number of sample of this study in Informatics Engineering Departement of Sainstek UIN Sunan Kalijaga Yogyakarta.

Respondent	Number of population	Number of sample
Student who not receive entrepreneurship course	120	= 32% x 125 x 1000 = 40
Student who receive entrepreneurship course	100	= 32% x 125 x 1000 = 40

### 3.2.2 Questionnaire Test

In the questionnaire testing phase was divided into two tests, there are validity and reliability test.

#### 3.2.2.1 Validity Test

To measure the accuracy of the data are using technique validity test that calculated with product moment correlation, the Pearson formula. Then the result of rxy consulted with a table of product moment rates critical, the result was declared as a valid questionnaire.

#### 3.2.2.2 Reliability Test

To know the reliability of the questionnaire, this study uses alpha formula. Based on the analysis of the data, the result is reliable, the reliable is meaning full for further research.

#### Mann Whitney Test Data Processing

Mann Whitney test is two independent samples test in non-parametric statistics that has the same goal with the statistical parametric T-Test (Suranto: 2009)<sup>8</sup>. Processing Mann Whitney test used to determine the differences of entrepreneurial mental among students who did not get and get the material entrepreneurship. Measurements

of entrepreneurial mental obtained from closed questionnaires to students who do not get and get the subject of entrepreneurship.

1. The data that will entry into the SPSS release 17 should be numeric data and nominal type data, with the rules:
  - a. 1 = Students who did not get entrepreneurship course
  - b. 2 = Students get entrepreneurship course
2. After that, input the data tabulation that shown in Table 3 into the SPSS 17 software. Below the display of data entry in SPSS release 17 data editor.
3. After entering the data entry and then select the Analyze menu, select submenu nonparametric test, then the option of 2-independent sample so that will appear dialog box Two Independent Samples Test.
4. Then move the "EntrepreneurialMental" variable into the Test Variable List box by pressing the arrow to the right.
5. Move the variable "Treatment" into the Grouping Variable by pressing the arrow to the right.

6. Then click the Define Groups button and then enter the value 1 in group 1 and value 2 in group 2.
7. After that the Test Type box click the Mann Whitney U, and then click on Options if you

want to get the value of descriptive statistics and then click OK to display all the output of the Mann Whitney test and finally can be seen in table-3

Table 3. Output of Mann Whitney Test

Descriptive Statistics					
	N	Mean	Std. Deviation	Minimum	Maximum
Entrepreneurial mental treatment	80	108.83	7.525	96	136
	80	1.47	.503	1	2

Ranks				
treatment	N	Mean Rank	Sum of Ranks	
Entrepreneurial mental	1	40	38.26	1722.00
	2	40	50.14	2106.00
Total	80			

Test Statistics <sup>a</sup>	
	Entrepreneurial mental
Mann-Whitney U	686.000
Wilcoxon W	1722.000
Z	-2.008
Asymp. Sig. (2-tailed)	.021

a. Grouping Variable: treatment

### 3.2.3 Mann Whitney Test Analysis

Mann Whitney test analysis can be seen in Table -3 descriptive Statistics, Rank and Test Statistics. The information that we get as follows:

1. From table-3 Deskriptive Statistics we obtained information that the total sample about 80 students in informatics engineering, Sainstek UIN Sunan Kalijaga Yogyakarta. The average value (mean) of 108.83. Value of standard deviation of 7.525. Value (score of entrepreneurship mental that results obtained from the questionnaire), a minimum score of 96, while the maximum score of 136.
2. From Table-3 Rank, we received information about the "treatment" variable. The "treatment" here means two groups of students who receive different treatments. First is

- student who did not get entrepreneurship, and second is students who receive entrepreneurship in informatics engineering, Sainstek UIN Sunan Kalijaga Yogyakarta. The information that obtained as follows: a). Number of samples for students who do not get entrepreneurship course as many as 40 students. b). The number of samples for students who receive entrepreneurship course as many as 40 students. c). The average score of Rank for students who do not get entrepreneurship course as many as 38.26. d). The average score of Rank for students who get entrepreneurship course as many as 50.12.
3. From the Test Statistics table we obtain the following information:
  - Mann Whitney U value = 686
  - The value of Z = -2008

• Asymp. Sig (2 - tailed) = 0.021

4. Hypothesis Testing:

$H_0$ :  $X_{1a} = X_{1b}$  (There are no differences in entrepreneurship mental among students who did not get and get entrepreneurship)

$H_1$ :  $X_{1a} \neq X_{1b}$  (There are some differences in entrepreneurship mental among students who did not get and get entrepreneurship).

5. Decision

By comparing the numbers Zcount and Z table. For the 95% confidence level and two-sided test, the result of Z table are  $\pm 1.965$ . Therefore, the value of Zcount that located in the  $H_0$  is rejected or Zcount -2008 < -1.965, then the decision is rejecting the  $H_0$  or it means there are significant differences between students who did not get and get entrepreneurship course. Because the number at table 3- Asymp. Sig column showed 0.021 < 0.05; so,  $H_0$  is rejected. This means that there are significant differences between students who did not get and get entrepreneurial. Value or score of entrepreneurship mental obtained from questionnaire results showed that the scores of entrepreneurship mental students who receive entrepreneurship course is higher than students who did not get entrepreneurship course, so it can be interpreted entrepreneurship learning has a positive influence on the growth of entrepreneurial mental in students.

## 4. CONCLUSIONS AND SUGGESTIONS

### 4.1 Conclusion

Based on the analysis that has been done and the purpose of research can be concluded as follows: The hypothesis from processing of Mann Whitney test with SPSS release 17 software obtained statement that "There are differences in entrepreneurial mental among students who did not get and get entrepreneurial course in informatics engineering, Sainstek UIN Sunan Kalijaga Yogyakarta, it seen by calculating the value of Zcount < Z tables (-2,008 < -1,965) and also the value of probability is 0,021 < 0,05 then  $H_0$  is rejected and on based on the hypothesis can be concluded that students who have received entrepreneurship material has better entrepreneurial mental. It is "proven" appropriate with indicator of independent and professional business with characteristics; independence effort, management skill, the skill of thinking, innovative, creative, dare to try, never give up, the spirit of trying, trying ideas, job-oriented, dare to face the risks, responsibilities, work hard, ready to work under pressure, networking, broad thinking, self-development and work professionally.

### 4.2 Suggestion

After doing research, it is suggested that entrepreneurship learning in informatics engineering Sainstek UIN Sunan Kalijaga Yogyakarta should be oriented to the process and outcome of the assignment due to the application directly can improve entrepreneurial mental as well as improve the learning. It should apply the teaching methods like interactive, applied, participatory, so after graduating entrepreneurship course, the college student do not lose their entrepreneurial mental but it can be used as value for point in self-development.

## ACKNOWLEDGMENTS

To Agus Mulyanto as the head of Informatics Engineering Department on Sainstek UIN Sunan Kalijaga Yogyakarta, the entire academic community Sainstek UIN Sunan Kalijaga and Dean of Sainstek that give the permit this research, providing facilities and support the researchers, students of Informatics Engineering which becomes the object of research, and also Defi Apriliani for her help in data collection, discussion and thank you for analyzed the data of this research.

## REFERENCES

- [1] Badan Pusat Statistik. *Pengangguran di Indonesia*. Jakarta. 2009.
- [2] Zimmerer. W. Thomas. Norman M Scarborough. *Entrepreneurship and New Venture Formation*, New Jersey : Prentice Hall International Inc. 1996.
- [3] Suryana. "Kewirausahaan, Pedoman Praktis, Kiat dan Proses menuju Sukses", Penerbit Salemba Empat , Jakarta. 2003.
- [4] Istiningih, Shopian dan Murniasih. *101 Tips Belajar Efektif Dan Menyenangkan*. PT. SindurPress : Semarang. 2009.
- [5] Qomarun, *BPK Kewirausahaan*. Jurusan Arsitektur. FT. UMS. Surakarta. 2000.
- [6] Apriliani, Defi. Djunaidi, Suranto. *Pembelajaran Kewirausahaan Meningkatkan Mental Berwirausaha Mahasiswa*. Skripsi. Teknik Industri. UMS. Surakarta. 2011.
- [7] Arikunto, Suharsimi. *Prosedur Penelitian Suatu Pendekatan Praktis*. PT. RhinekaCipta : Jakarta. 2006.
- [8] Suranto. *Metodologi Pendidikan dengan SPSS*. Gyas Pres Semarang. 2009

# TRAINING AND SKILL DEVELOPMENT IN INDIVIDUAL'S PRODUCTIVE CAPACITY

Muhamad Thaufiq Pinat

mtpinat@yahoo.com

## Abstract

The vocational education and training can help individuals to generate income and contribute towards economic growth and social development of a country by acquiring knowledge and skills. A better educated labor force is essential if we are to meet the labor supply requirements of faster growth. Economic growth of a country crucially depends on skills for producing goods and services of better quality at competitive prices. Training and skills development play a vital role in individual's productive capacity and are integral part of Human Resource Development. Vocational education and training to effectively support industrialization, economic growth, wealth creation and poverty eradication, skills training must be of high quality and competency-based. Vocational education and training development is needed in the preparation professional labor force in the field of engineering for national development purposes.

**Keywords:** *income, labor force, professional, vocational education and training.*

---

## 1. Introduction

The low quality of vocational education and training in Indonesia is one of the causes of the increasing unemployment of the labor force from year to year. This certainly makes the government became increasingly heavy burden for reducing unemployment. Meanwhile, population growth rate increased sharply each year, not comparable with the availability of employment. Whereas these jobs can be created by people who have a particular field of expertise and skills such as carpentry experts, workshop, mining, shipping, automotive and other experts that are needed by industry and business.

Expertise and skills required by industry is still difficult to be met by the vocational technological education, is caused by quality insurance in vocational schools and other institutions Vocational Education yet according to the industry model. Under these conditions required a comprehensive study to find the right model, so it can meet the requirements desired by industry and business. Therefore, improving the quality of vocational education continuously (continuous improvement) inevitable. Because of the relevance and quality of secondary vocational education is still low, access to secondary vocational education services have been inadequate, plus management education is still not efficient (Secondary Vocational Education, 2004).

Training and skills development play a vital role in individual's productive capacity and are integral part of Human Resource Development (Javied and Hyder, 2009). Human resource development improves economic growth and productivity. Economic growth of a country crucially depends on skills for producing goods

and services of better quality at competitive prices (Asgar and Siddiq, 2008; Khan, 2005; Mouzakitis, 2010). Rapid economic growth demands a mixture of skilled worker; technician, technologist, engineers, research professionals and innovative scientists trained in the areas linked with national development and need of the industries. The accelerated economic progress of the Asian Countries like China, Japan, Malaysia and also Australia are the excellent examples in point. It is an established fact that technical education and vocational training can help individuals to generate income and contribute towards economic growth and social development of a country by acquiring knowledge and skills (National Skill Strategy, 2008).

Indonesia's workforce is characterized as having comparatively low skills and less prepared to compete in today's globalized world. Rapid technological changes now require individuals to learn and relearn skills throughout their working lives by ensuring its relevance and effectiveness. The most important outcome of an effective human resource development system is that it opens up decent employment opportunities by enhancing workers' abilities to secure and retain jobs, progress at work and cope with the change (Kazmi, 2007, p-105).

## 2. Problem Identification

- The number of unemployed vocational graduates,
- The low quality of graduates,
- Vocational school graduates lack the skills can be counted on to be used in the world of work.
- less trained in theory and practical tasks
- The curriculum is less oriented towards

- the needs of industry
- Teaching methods do not keep up with today's technology.
- Improving knowledge of the need for teachers to renew the theory and practice of learning methods.
- Lack of enthusiasm of teachers to seek new knowledge in order to support student achievement.
- Lack of control to guarantee the quality of graduates.
- The low awareness of the industry both government and private companies provide opportunities to students and college students to carry out the practice of industry experience.
- Concepts such as Work Based Learning: Apprenticeship and Internship has not been fully implemented.

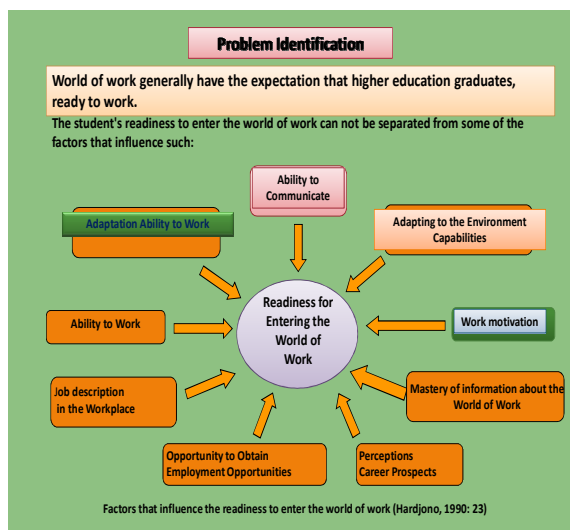

Figure 1. Problem Identification

In figure 1 above describe there are nine factors that influence the readiness to enter the world of work influence the Readiness for Entering the World of Work:

1. Ability to Communicate,
2. Adaptation Ability to Work,
3. Ability to Work,
4. Job description in the workplace,
5. Opportunity to obtain employment opportunities,
6. Adapting to the Environment Capabilities,
7. Work motivation,
8. Mastery of information about the world of work,
9. Perceptions Career Prospects.

The whole factors that influence to enter the world of work should be answered by arranging training and skill programs. In addition, the programs should support the ability that are

needed by the world of work which have high competitiveness.

### 3. Discussion of problems

Technical education and vocational training institutions should ideally have to devise their technical education and vocational training exactly according to the requirements of industry in the context of globalization (Javied and Hyder, 2009).

Guthrie argues that professional development is just one approach to improving the quality of the VET workforce. A strong professional culture in the workplace and better approaches to recruitment, job design, industrial relations and workplace and performance management also need to play their part. Whatever the approach, professional development needs adequate resourcing if it is to be effective. NCVET (2010;46)

Vocational training will play an important part in helping local people to make the most of the employment opportunities to find alternative employment and livelihoods in the long-term.

Targeted schemes now in place, or in planning, are designed to improve basic numeracy and literacy skills, prepare local people for employment during the construction phase, and to equip them with broader skills that will help them find new employment opportunities and livelihoods following completion of the project.

It's likely that training will focus on helping people develop technical trade skills in construction (including masonry, carpentry, electrical fitting and plumbing) and service industries.

We believe that vocational training of this kind will help to reduce the dependency of people living in the work place by helping them to take up alternative employment opportunities.

### 4. Vocational Education Strengthening Project of Government of Indonesia

National and local governments are concerned that too many graduates are leaving high school without the skills necessary to ensure their economic welfare, and to contribute to national economic and industrial development. The Governments policy to strengthen the quality and relevance of vocational education and training is part of its broader social and economic policy. The vocational education system Indonesia largest investment in sub professional skills development has more than 6,800 public and private vocational schools with a total enrollment of over 2.86 million. Ensuring that the system responds to Indonesia economic and employment needs is therefore a high priority Government consultations with industry indicate



(i) some industrial developments are constrained due to Indonesia comparative lack of skilled workers, and (ii) widespread concern about the lack of relevance of some vocational schools courses to industry requirements. The need to strengthen ties with local industry is strong; the Project will provide continuous upgrading courses for vocational schools graduates and other workers. Growth in formal sector employment opportunities has stagnated in recent years with unemployment and underemployment becoming significant social concerns and slowing poverty reduction. Vocational schools graduates are considered to have strong potential for generating self-employment and for small-scale employment creation. To strengthen entrepreneurship skills, the Project will ensure the introduction of entrepreneurship training in all model schools, supported by productive activities in school production units and business incubators.

Assessment of potential measures will cover advantages/disadvantages of different modality of program delivery (formal/non-formal), integrating assessment involving the beneficiary communities. Assessment of optimal link and match with industry for the technical and vocational students will be made.

Government needs to monitor its own performance against its policy objectives and support schools to improve the quality of what is being taught and the effect this has on local labor markets, this can be measured through revised curriculum, endorsement of curriculum by industry and through tracking the employment activities of graduates.

**Training and Skills development:**

- Similar to development:
- Provides new skills for the employee
- Keeps the employee up to date with changes in the field
- Aims to improve efficiency
- Can be external or 'in-house'

The result of training will get the formula below:



Figure 2 Triangle Model Work Culture.

Individual's Productive Capacity can be achieved when labor forces have performance like in figure 2 Triangle Model Work Culture above. According to this formula:

- Between **Accountability** and **Responsibility** there is **Honesty**.
- Between **Responsibility** and **Authority** there is **Fairness**
- Between **Accountability** and **Authority** there is **Wisdom**.

Productivity a job is supported by a good performance, when it is done by a labor force that has **Honesty, is Fairness, and Wisdom**.

Those are can be formed from Education and Training.

**5. Problem solving**

For that human resource development should include the five areas:

1. Quality of work
2. Productivity
3. Satisfaction Resources
4. Resource development
5. Readiness for change

If it can be developed into nine aspects:

1. Exercise and development through a planned educational identify, assess, and help to develop students' abilities (knowledge, skills and attitudes) therefore they have ability to perform their works now and future.
2. The availability of institutions that organize the development of healthy relationships between groups to initiate change and manage change.
3. Planning work that focuses how the work can be done, and how the system and authority in distributed and arranged between the organization and duties of each individual.
4. Planning human resources in charge of determining the basic needs, strategies, and philosophies of human resource development.
5. Selection and appointment of a man with a ladder match in charge of his career through the consideration of abilities and career path available.
6. Manpower information system that provides necessary information about the world of work.
7. Wages that ensure fairness and stability remuneration.
8. Assistance provided to individuals in the form of counseling for the rise of problems and the impact of the work.
9. Organization healthy workers who establish rights and obligations of a worker.

There are six concepts are formulated Rupert Evans in the world of vocational education:

1. Vocational education is economic education as it is geared to the needs of the job market and thus contributes to national economic strength.
2. Vocational education can develop a marketable man by developing his ability to perform skills that extent his utility as a tools of production
3. Vocational education is education for production of serve the ends of the economic system and is said to have social utility.
4. Vocational education at the secondary level is concerned with preparation of the individual of initial employment
5. Vocational education should be oriented to the manpower need of the community.
6. Vocational education should be evaluated on the basis of economic efficiency.

## 6. Conclusion

Through Training and Skill Development in Vocational Education will make increased competitiveness and employment opportunities for vocational school graduates.

Through Training and Skill Development in Vocational Education will make improved quality and relevance, expanded access, and greater efficiency in senior secondary vocational education.

By having a good management Training and Skill Development in Vocational Education in various area in technology for vocational school graduates

Vocational education should be oriented to the manpower need of the community.

Vocational education should be evaluated on the basis of economic efficiency.

Do efforts to repair, among others:

- Revised curriculum is oriented to the industry field and the world of work
- Changes in competency-based teaching system by referring to the industrial model.
- Improving facilities and infrastructure.
- Development of quality and quantity of teachers and lecturers.
- Supporting Training and Skill Development program by Industries.

Training and Skill Development in Individual's Productive Capacity can be achieved by doing the efforts above.

## REFERENCES

- [1] Australian Department of Education, Employment and Workplace Relation, Commonwealth of Australia 2011. *Research messages 2010*, NATIONAL CENTRE FOR VOCATIONAL EDUCATION RESEARCH (NCVER): Adelaide, Australia.
- [2] Harris, Roger Michele Simons and Julian Moore 2005 *'A huge learning curve': TAFE practitioners' ways of working with private enterprises*, A National Vocational Education and Training Research and Evaluation Program Report (NCVER)/Australian Government: University of South Australia.
- [3] Inamullah, H.M; Naseeruddin, M; Hussain, I & Iftikhar, S. 2009. *The Development of Technical Education in Pakistan*. International Business & Economics Research Journal. 8(1): 87-90.
- [4] International Labor Organization 2008. *Labor and Social Trends in ASEAN 2008 Driving Competitiveness and Prosperity with Decent Work*, ILO: Bangkok.
- [5] Jacobs J. Ronald 2003. *Structured On-The Job Training Unleashing Employee Expertise in the Workplace*, Second Edition, Berrett-Koehler Publishers, Inc. San Francisco: USA.
- [6] Javied, Z, & Hyder, A. 2009. *Impact of Training on Earnings: Evidence from Pakistani Industries*. Asian Social Science. 15(11): p-76-85.
- [7] Jurnal Pendidikan Vokasi, Volume 1, Nomor1, Februari 2011 ISSN: 2088-2866.
- [8] Khan, M.A. 2005. *Human Resource Development, Competitiveness and Globalization: A South Asian Perspective*. SAARC Journal of Human Resource Development 1: 15-54.
- [9] Middleton John, at all. 1993. *Skills for Productivity Vocational Education and Training in Developing Countries*, Published for the World Bank Oxford University Press: New York.
- [10] Mitchell Garry 1998 *The Trainer's Handbook: The AMA Guide to Effective Training*, AMACOM: USA.
- [11] Mouzakitis, G.S. 2010. The role of vocational education and training curricula in economic development. *Social and Behavioral Sciences* 2: 3914–3920.
- [12] Noe, Raymond 2001. *Employee Training and Development*, Mac Graw Hill: New York.
- [13] Park, M.G. (2005). *Knowledge producing partnerships and collaborative ventures between the academy and industry*. Retrieved from [http://www.unevoc.net/fileadmin/user\\_upload/docs/8-Park.pdf](http://www.unevoc.net/fileadmin/user_upload/docs/8-Park.pdf) on June 13 2010.

# INTEGRATING VIRTUAL TRAINING ENVIRONMENT INTO VOCATIONAL HIGH SCHOOL TO FACILITATE CHARACTER EDUCATION TO DELIVER A PROFESSIONAL WORKFORCE

Hendra Jaya<sup>1</sup>, Sapto Haryoko<sup>2</sup>

<sup>1,2</sup> Department of Electronic Engineering Education  
Faculty of Engineering, Makassar State University  
<sup>1</sup>hendramisi@yahoo.com , <sup>2</sup>saptoharyoko@yahoo.com

## Abstract

The success of workers in the electronic field is not only determined by the mastery of hard skills but also of soft skills. The soft skills can reach by using an Information Technology (IT) through multimedia. A New technology introduced based on virtual reality for training activity. Virtual laboratory consists of collaborative learning, training program, and student's character assessment form. Virtual training was developed in productive subjects are supported by the software authoring tools web based. Virtual training are interactive, dynamic, and animatif, not boring and can to support the user desires to learn and understand training material. Virtual training improved the competence students of vocational high school in the form of cognitive aspect, psychomotor aspect, and character (affective) aspect. Through integrated virtual training environment into student of vocational high school in facilitating character education become a basic to prepare the student to entering in the workplace. Character education should begin in the vocational high school to improve the competence of vocational labor force.

This paper is proposed to facilitate the character education through virtual training environment. It is a fact that virtual training has been a scope of interest for vocational training for a very long time. However, it needs more time to be more common in all specific training fields. Interactive teaching program was developed and put into a website to form a virtual training centre.

Keywords: Virtual Training Environment, Character Education, Vocational high school.

---

## 1. Introduction

During the 1960's and 1970's, teaching and learning tools were nothing but a piece of chalk and a blackboard, eraser, teachers and students who met each other face to face inside the classroom during class. In the 1980's, videotape programs were used as teaching aids. In the 1990's, one-way teaching by computer arrived. And finally today's advanced computer and information network technology has introduced radical innovative breakthroughs in our teaching and learning methods as well as in the learning environment. Students can listen to their teacher or trainers in distant classrooms through PC's and get a simultaneous view of their teachers and texts as well. They can ask questions and record the "class" for repeated viewing. Training organizations can conduct professional training directly via the computer network. These learning environments are not so different from a teacher-guided class with discussions and tests as well [1].

One of the concrete future strategic objectives of education and training systems in vocational high school is the improvement of the quality and the effectiveness of education and training systems in the workplace. This includes

improving education and training for teachers and trainers, developing skills for the students, ensuring access to ICT for everyone, increasing recruitment to scientific and technical studies, and making the best use of resources. The second strategic objective is facilitating the access of all to education and training systems. This objective includes open learning environment, making learning more attractive, and supporting active citizenship, equal opportunities and social cohesion.

## 2. Distance Learning

Traditionally, distance learning is defined as a means of providing access to educational courses or programs for students who are separated by time and physical location from a teacher. The courses or educational programs are packaged as a collection of lecture notes, exercises, assignments, and examinations assembled in the form of either a binder, a set of cassette tapes, or CD-ROMs, or a set of video tapes that an institution ships out to a distance student. The student who is an isolated learner, meeting certain predetermined deadlines, sends back the course work and completes the course with little or no interaction with teacher or

course monitor. Unfortunately, this perception of distance learning still prevails. Today's information technologies and web-based software packages such as Lotus Notes provide resources to simulate a classroom in a virtual setting allowing a rich interactive distance learning experience, which in some cases can surpass the interactivity of a traditional classroom. Considering extensive use of information technology we, thus, define or rather redefine distance learning as "interactive distance learning" that provides a virtual classroom using interactive technologies such as web, internet, multimedia, etc. Instead of teaching, it promotes learning experiences based upon a variety of interactions including teacher with students, students with other students, students with other experts in the field, students with resources such as posted lecture notes, reference books, other web sites, etc. Through the use of technology, these interactions can occur at any time or place providing a 24X7 hours learning environment [2].

Learning models are frequently described as points on a spectrum. As depicted in Figure 1, at one extreme is instructor-led training (ILT, also referred to as classroom training or direct instruction). At the other end of the spectrum is a family of technology-based models including computer based training (CBT) and web-based training (WBT). Collectively, models at this end are grouped into the e-learning category. Blended learning occurs between the two extremes, which is a combination of direct instruction and e-learning.



Figure 1: Spectrum of Learning/Training Models

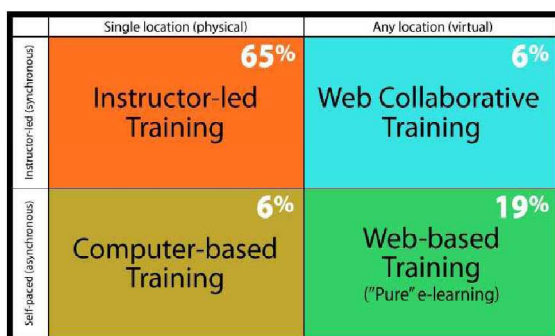

Figure 2: Training Models Shown in Two Dimensions [13]

### 3. Virtual Training Environment – An Ideal Training Place

The Virtual Training Environment models the new training environment, which is a place that students can customize their study in their own pace. Providing up-to-date training material and personal study guide, it is an ideal study environment for the 'life-long' learners. The main

goal of the Virtual Training Environment is to deliver the 'own-paced' material to the right person at any time. In the Virtual Training Environment, students can fully engage in the training process through an interactive, dynamic environment. The on-line material for each student is scheduled personally depending on his/her studying pace. Consequently, students will not waste their time learning irrelevant or already-known material, while other students may fail to understand the material. In addition, the Virtual Training Environment supports group-paced learning. The collaborative facility allows students to accomplish group projects and discussions.

The Virtual Training Environment not only transmits information to the students, but also provides forums for exchange. When group members participate and share their knowledge, their knowledge base increases and members continue to benefit [6]. This kind of real-time communication is not restricted to only peer interaction (student/student). It can also encourage active participation of students and the instructor in a shared task for understanding and applying the concepts and techniques that characterize a subject area [7].

### 4. Teaching Road Safety using computer applications

A substantial amount of Road Safety teaching material consists of multimedia and hypermedia applications. What is easily ascertained is that almost all of them focus on knowledge acquisition. Very few include some form of road simulation, even so, student's active participation is limited. In general, these applications present traffic situations with the use of static or animated graphics and ask student to make judgments about what to do next, if there is something wrong, what should have been done and so on. Even if this can be considered as a form of training in detecting dangerous situations, it does not train any of the crucial pedestrian skills.

Two research projects came to our attention that used computers for training specific skills [8]. The first one investigated the problem of distraction in children's attention and how audiovisual search strategies can be applied to help in partially solving this problem. The second research project examined how the pedestrian skills of safe place finding, roadside search, gap timing and perception of others' intentions can be improved [9]. Training in each of the above skills was a separate module of the application, with four training sessions in each one. All modules shared the same small town setting and a common cast of characters to emphasise the relationship between the skills. The activities in each training session were about making decisions on if, when or how the character that represented the child in the

application should cross the street. When a decision was made, the character crossed the street and the computer demonstrated the consequences of that decision.

### **Virtual Reality**

The two research applications presented in the previous chapter derive their theoretical background mainly from the theory of constructivism as it was shaped by Piaget and Vygotsky [9]. This is a common place for multimedia and hypermedia applications, because ideas of constructivism are easily realised. A basic attribute of multimedia and hypermedia applications that renders them compatible with the theory of constructivism is that they allow non-linear access to the content, thus leaving students free to select their course. In general, the main characteristics of a constructivist teaching approach -computer based or otherwise- as noted are [10]: a) it offers multiple and complex presentations of reality, avoiding simplifications; b) it engages students with authentic tasks; c) it helps knowledge to be constructed in relation to its content; d) it encourages practices based in reflection; e) it supports collaborative learning instead of competition amongst students.

VR applications encapsulate all the features of multimedia; hence, they also have close relationship with constructivism. However, VR holds a significant advantage over multimedia applications: it can present vastly more complex and realistic presentations of reality. The basis for this attribute is mainly technological, but from a cognitive perspective this happens because VR offers a specific type of experience and does not require the use of symbols [11]. It is worth analyzing this assertion. First we have to indicate the value of an experience. The experience (virtual or real) with which an idea or a portion of knowledge is associated is important for the comprehension of the idea/portion of knowledge as much as for the use of it [12].

## **5. Discussion**

The Virtual Training Environment (VTE) is a Web-based knowledge library for Information Assurance, computer forensics and incident response, and other IT-related topics. Five important factors that contribute to learning were taken into account in order to prepare the training: 1) motivation, 2) aptitude, 3) presentation, 4) repetition, and 5) practice with reinforcement. The approach for developing the appropriate training material was based on the following key concepts: 1) motivation, 2) know your electronics identification, 3) prepare to write programs, 4) understand the motion types, 5) know the compensation types.

The VTE aims to improve the skills and competences of people to promote and reinforce the contribution of vocational training to the process of innovation, with a view to improving competitiveness and entrepreneurship, also in view of new employment possibilities. The specific aims of VTE can be defined as follows: a) training the trainers, trainees, technicians and apprentices and all enthusiastic about Electronic services; b) preparing technicians as intermediates having common measurable qualities the industry is seeking; c) helping to form a labour force that can use current knowledge and technology, and thus, in search for life-long learning; d) supporting the sectoral communication through the national centres in partners; e) setting up a website to publish the data collected; f) adapting the collected materials to enhance the new curriculum satisfying the requirements in a modern sense; g) helping to improve and upgrade competences and skills of the involving institutions' didactic staff and exchange experiences over the virtual training environment; h) enabling the participants to extend the common educational qualifications of electronics services tools technologies; i) the accreditation of the skills and knowledge of electronics services tools technologies acquired within the network created between participating institutions and organizations; j) increase the quality of employment through qualified workers; k) helping to increase active use of technology acquired and thus to increase the standards; l) contributing to individuals by behaving through life long learning; m) having a labour power in accordance with common design and production standards; n) contributing to labour market by using the common technology and equipment effectively; o) helping to enhance available potential of human sources. Target groups include trainers, trainees, technicians, apprentices and all enthusiasts about Electronic Services. The final and potential users of the project's results are the training organisations, the dealing with electronics repair, and the universities, colleges, vocational schools, and training centres.

Students need to develop the necessary skills and methods that will eventually render them capable of tackling complicated traffic situations. The most effective teaching method is expected to be one that simulates nearly real traffic conditions. Solutions, like traffic parks, roads closed to traffic and even a 'pretend road' method, were tested by research teams for their effectiveness and found to produce positive outcomes. Nonetheless, it is impractical to incorporate such methods in everyday school teaching. Such solutions would require a number of actions and prerequisites that are time consuming, expensive and depend on imponderable factors. Among others, the requirements include finding the appropriate

location for the 'pretend road', construction of the necessary infrastructure, transportation of students to and from that location, hiring and training a sufficient number of adults who will act as guides-tutors to students, revision of the school's curriculum and timetable and finally good weather that is needed for outdoor activities.

Considering all the above on a national scale it is obvious that a more practical, feasible and cost effective solution is needed. In the field of ICT, Internet and multimedia are the prevailing type of applications. The problem is that applications of this type aim at knowledge acquisition, which is not the major factor in Road Safety. A very limited number of them focus on training skills, with encouraging results. These applications can be described as 2D simulations of an environment, in which the user/student has to face a number of traffic situations. Simulation is the key element of their success. But simulations are more closely related to 3D rather than to 2D graphics. Therefore one has to examine the possibility of using VR (a broader type of 3D simulations) in order to provide skill training.

From a theoretical perspective, the underlying cognitive theory both in multimedia and in VR is constructivism. This theory suggests that knowledge is constructed and not simply transmitted through teaching, admits that each individual creates their own representations of the world, acknowledges that we learn via active exploration and finally points out that learning is a dialectic and interactive activity with our social environment. VR encapsulates these ideas, through the non-linear exploration of the content, the provision of elements that arouse the learner's interest, interaction-collaboration with other users present and through manipulation of the environment's objects. All of these characteristics can also be found in multimedia applications. Nevertheless, the capabilities of VR extend even more, since it is possible to present vastly more complex and realistic environments. Furthermore, first person view puts the user literally inside the virtual world, giving him/her the chance to have first person experiences, with the additional advantage -with the use of specialised hardware- of not having the need to use symbols for interaction with the virtual objects.

The benefits of using VR for training environment: a) Training needs to be done in a manner very close to real traffic conditions. No other training form; b) conventional or ICT based-can provide students with enough elements that will help them improve co-ordination of information from different directions, visual timing judgments, coordination of perception and action. An obvious example is pilot training using simulators. It is possible to simulate traffic situations that are very

complicated to be presented in reality, or extremely dangerous for students to be exposed; c) Contrary to other teaching techniques, in VR, students are not limited to third person experiences in order to acquire the necessary knowledge, thus missing, to a large extent, the benefits offered by first person experiences; d) The elevated degree of interaction with the virtual world gives students the chance to test alternative approaches in a traffic situation, to experiment and learn from their mistakes; e) The playful character -VR applications are, up to a degree, very similar to modern computer gamesstimulates students' interest and gives extra incentives for learning; f) The teacher can be present in the virtual world. Therefore, different teaching styles can be implemented. For example, collaboration between students, guided tutoring, or a combination of collaboration and tutoring is possible.

The virtual training facilitate the character education through the job sheet or piece assesment to show a level of character of the students. Media of training will be design by using a character education.

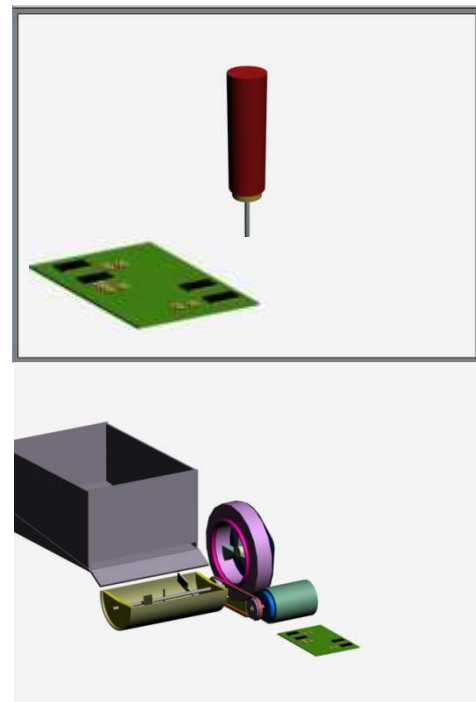

Figure 3. Virtual Training Electronics Service

## 6. Conclusion

The integration of ICT in this virtual training environment for electronic services course, the student demand and interest in increasing the quality of education through ICT. At the national level, integration of ICT should become a key priority with national and regional institutions making a commitment to ICT and the development of networks. Virtual Training Environment addresses the strategic objectives mentioned above:

improving the quality and effectiveness of education and training systems in vocational high school by developing skills for the knowledge society, ensuring access to ICT for everyone, increasing recruitment to scientific and technical studies, and making the best use of resources. Facilitating the access of all to education and training systems by providing open learning environment, making learning more attractive, and supporting active citizenship, equal opportunities and social cohesion is the other strategic objective that can be achieved through this virtual training environment.

### REFERENCES

- [1] M. Sahin, S. Yaldiz, F. Unsacar, B. Yaldiz, N. Bilalis, E. Maravelakis, A. Antoniadis. Virtual Training Centre for Computer Numerical Control. *Int. J. of Computers, Communications & Control*, ISSN 1841-9836, E-ISSN 1841-9844 Vol. III (2008), No. 2, pp. 196-203.
- [2] Khalid J. Siddiqui and Junaid A. Zubairi. Distance Learning Using Web-Based Multimedia Environment. Department of Mathematics and Computer Science SUNY College at Fredonia, Fredonia, New York.
- [6] Karen E. Goeller, "Web-based collaborative learning: a perspective on the future". *Computer Networks and ISDN Systems* 30 (1998) 634-635.
- [7] Lynnette R. Porter, "Creating the virtual classroom: distance learning with the Internet, New York: J. Wiley & Sons, c1997.
- [8] Emmanuel Fokides. *Virtual Reality in Education: A Theoretical Approach for Road Safety Training to Students*. Aegean University. *European Journal of Open, Distance and E-Learning*.
- [9] Tolmie A., Thomson J., Foot H., McLaren B., Whelan K. (1998), 'Problems of Attention and Visual Search in the Context of Child Pedestrian Behaviour', Department of Transport, Road Safety Report No. 10.
- [10] Jonassen D. H. (1994). Thinking technology: Toward a constructivist design model. *Educational Technology*, 34(4): 34-37.
- [11] Winn, W. (1993). A Conceptual Basis for Educational Applications of Virtual Reality. Human Interface Technology Laboratory, Report No. TR-93-9.
- [12] Jonassen D. H. (1994). Thinking technology: Toward a constructivist design model. *Educational Technology*, 34(4): 34-37.
- [13] Jim Wrubel, David White, Julia Allen. *High-Fidelity e-Learning: SEI's Virtual Training Environment (VTE)*. Carnegie Mellon University.2009.



# **NATION & CHARACTER BUILDING; TO DEVELOP AND MAINTAIN THE STABILITY OF PROFESIONALISM TO ACHIEVE OPTIMUM PRODUCTIVITY AND QUALITY**

**Dra. Hamiyati**

Affiliation Ilmu Kesejahteraan Keluarga-Fakultas Teknik-Universitas Negeri Jakarta  
hamiyati32@yahoo.com

## **Abstract**

Indonesia has the nation's ideals the realization of a prosperous society, noble in behave, and noble character with a republican form of the unitary state of Indonesia based on national unity and integrity, to make it happen required the construction of nation character building and the hard work of all components of the nation together - together to defend the interests of all countries, in order to compete with other nations in facing challenges in the global era, there are several challenges at once with the alternative government policies in anticipation of education and employment problems in Indonesia. Of which is the world's changing, competitive world, new economy, required competencies, and regional autonomy, Indonesia must ensure the readiness of human resources that are reliable and able to compete globally di era this, for the sustainability of development, one of the main factors that determine the success of development is the availability human resources quality, which has the competence needed for the development of industry and other sectors, it takes a comparative advantage and competitive advantage will enter the labor force labor market competition, professionalism and work ethic can not be separated, by means of adequate education infrastructure and will get a professional graduates.

**Keywords:** Nation character building, human resources, professionalism, and competitive advantage

---

## **1. Preliminary**

Professionalism is one of the foundations to achieve optimum productivity and quality, to achieve a steady professionalism required some prerequisites, such as education and knowledge, the quality of education and knowledge of the community is equipped to compete in life, especially in terms of work, education and knowledge in a broad sense including the formation of work ethics, technology and skills (competencies). Without a clear competence and good work ethic, it is difficult to work professionally.

Curriculum improvement is a priority in order to increase knowledge in line with the development of skills and expertise needed to meet the employment market, there are actually five aspects that need to be addressed in education, namely the hardware (physical facilities), software (curriculum and learning systems), brainware (teachers, students and parents), network (cooperative network), and dataware (data muridgurululusan). need to be inculcated early on a passion for entrepreneurship, so that knowledge learned in school can be practiced for the development of technology and living facilities, for, every student has equipped students with life skills (life skills) and entrepreneurship (entrepreneurship), so it can ease the burden of family and communities that have been loaded.

Education is one of the important pillars in nation-building. High-low degree and position of the nation can be seen from the quality of education that is applied. Appropriate and effective education that will give birth to the children of intelligent, moral, has a work ethic and innovation are high. The whole countries that have managed to achieve progress in the mastery of technology and civilization begins by giving great attention to national education. It is done in an effort to support, oversee, and continuously improve the system of education for their people. Streamline the process of education that instills a spirit of freedom and independence by cultivating the soul entrepreneurship for the existence of learners in the future through improved life skills and fighting spirit (adversity quotient).

Curriculum development efforts are directed to a balanced learning experience of the intellectual aspects (IQ), emotional (EQ), and spiritual (SQ) and implemented in a learning environment that is inclusive and free from discriminatory attitudes. Education needs to form the character of learners for students to possible learners can be lifelong learning. In addition to education and knowledge, skill is also one critical requirement. The current global era of much-needed skills, even for some types of skills must be supported by a certificate of competency (certificate of competence coc). Independent practice or internships to equip themselves with appropriate skill levels and fields,



and get a certificate of competency in order to compete in a global era.

To the later, public health is indispensable to improve the quality, the public health community can create power; who were on welfare and the estuary is one of the foundations to achieve the national security. Health care was held in plenary, covering aspects of physical, emotional and mental. Physical health is maintained and enhanced by ensuring adequate nutrient supply, particularly of infants and children, because they will become the successor to future generations. Emotional health is done by creating conditions for a peaceful family and a peaceful environment, as well as a positive association, especially among children children and adolescents because this is when the character of a human being is formed.

While it pursued a healthy life by promoting religious values and environmental transcendental cultural progressive, so that everyone can control the people living an increasingly heavy pressure, with a productive creative energies on the right target. The health sector reform aimed at improving infrastructure(houses pain clinic),increased the capacity of medical and paramedical personnel, and provision of medicines and medical devices are reachable.

Leadership or a persona that will either support the work ethic and professional enough for a person or group. Entrepreneurship is the nature and attitude that must be owned by all components of the nation to foster community self-reliance. Entrepreneurship can improve the productivity of the public to participate in wealth creation. Investment and the value of independence social solidarity are two sides of the formation of character (character building) that can not be separated. Often culminating in social problems conditions that have the attitude and behavior(mental models)are not in line with the changing times. Those who behave bad and always rely on the kindness others, including government policy intervention.

Therefore necessary to build new confidence and independence as a starting point value changes. The soul of independence instilled from childhood to adulthood would make every individual is able to solve problems in their respective environments, without waiting for instructions or outside intervention. However, a spirit of independence which to encourage it should not lead to symptoms of individualism and egoism, because it would undermine the social capital that have been stocked. Individual independence is built on the foundation of social solidarity that must continue to be expanded. Thus, forming a community that loves ko virtue. Irrespective of how the problem will be addressed, if this nation build a new national solidarity that unites a group all of society.

One reason for the high number of unemployment and poverty in Indonesia is the lack of optimal utilization of resources with fixed based on the sustainability of the system. Many of the nation's dependence on foreign Indonesia (especially economic) of them due to lack such optimization.

## **2. Discussion**

One concept that can be used as a framework for achieving goals - goals are the nation's independence and nation character building or the nationality and character development. Concept N & C Building namely national security, nationality, character (character development among other nations towards nations that have the identity characterized by having a democratic and human nature), and welfare, national character development can be done through several ways, as in the following description.

### **2.1 Developing qualified nation character building**

"To build Indonesian human intelligence, piety social, and cultural advancement for the sake of raising the dignity of the nation". mission can only be executed by strengthening exemplary factor in various fields, in a more heroic, the mission can be translated as "delete stupidity, social violence, and cultural backwardness," because we see ignorance (poor quality of education), violence (the loss of civility and peace in resolving any conflict), and backwardness (stagnation and cheese Mudan) as a social enemy of the whole nation, to build intelligence not only from the side intellectual rationality (IQ). But also covers the emotional side (EQ) and spiritual (SQ), so completed the human figure that will be built up (perfect man).

A very necessary quality in a social situation that is being dogged by the disaster. The new man is born through the coaching process and the cadre was very aware of her position and goals to be achieved. They are not experiencing an identity crisis as seen in some people around him, so that they can play a role as an element of environmental modifiers and steering people toward a common goal that has been launched. The new generation is also well aware of the reform agenda should they stand for. And in line with the ideals of freedom that has diproklamsikan long ago, they did not waver and dissolve in the changes times, even became pillars guard the values of struggle and create a new stream that will save people from dilapidation and destruction of social. Intelligent man who not only think about the interests and safety of themselves, but think about the interests and public safety.

The best human being will be fostered is their greatest contribution to society and those who

implement their adherence to the creator by doing good and serving as all creatures. Personal piety that cumulation became public piety will establish a positive environment for the development of the entire human potential (humanity) and citizenship (citizenry). It reflected the increased work ethic. Attitude will open a new creation and innovation, and strong social solidarity, with human support a new generation. Then the nation's identity crisis and modalities can be overcome, those who would change the conditions of underdevelopment into cultural advancement, personal improvement not only physical nature. However, we develop universal values of humanity, so that each citizen to realize the function and role of his life as a servant, leader, and builder of new civilization. Collective progress is also not just physical and material, but the proliferation of values and institutions of charity, and the depletion of the values and institutions into the vice. Cultural progress for this nation means a nation reawakened to her identity that has long been eroded.

All mission changes and improvements to community conditions will not be met without the presence of a person or group of people who spread the exemplary model (role model). Example in the private sphere (consistent character and reliability), family (harmonious and productive), society (harmonious and innovative), and the nation (beretos high and virtuous). Appearance of a new generation who have competence in various areas of life will overcome the crisis that policy can not touch the concrete problems of society and end the crisis exemplary among formal authorities.

Heavy mission will be achieved with a solid strategy and precise, ie, "improve quality of life and create social harmony in a cultural environment which is progressive and open". Quality of life of residents viewed comprehensively, including the adequacy of the primary needs (food, clothing, housing, vehicles and accounts), secondary (safety, business opportunities and civil liberties), and tertiary (freedom of expression, thought and creativity). Besides that, the increasing quality of life vertical-transcendental (faith in the omnipotent) and horizontal-sosietal (relationships with fellow human beings) would create social harmony that is needed by all her citizens, so that the rights and obligations can be done perfectly improved quality of life and embodiment of cultural harmony within the framework of a forward (future-oriented is better) and open (to learn from the environment locally, nationally and globally). This strategy will be outlined the importance of seeding new values (cultural), the new actors coaching in various sectors of life (personal), as well as changes in social structures, political and economic desired (structural). This strategy is run simultaneously, do not exaggerate or rule out one factor in above and

below other factors. However, attainment targets tailored to the actual development of society.

In a closer to reality with a vision, then arranged the main steps and supporters, these measures are more detailed and concrete explanation of the mission that has been outlined, as all these measures are related to each other and complement each other.

Of any steps we began efforts to solving the existing problems, then it will eventually be met, and you need support from the other side, the main steps are:

- a. Fulfillment of Basic Needs
- b. Education Participation Improvement, Quality
- c. Plenary Health Services
- d. Investment Value Independence and Social Solidarity
- e. Progressive Culture Movement

It's enough that we talk about culture in the conceptual level-academic, it is time to mobilize a new progressive movement in terms of: artist enlightened cadre, the formation of cultural communities in urban and rural areas, as well as assembling a network of local culture, national and global. Thus the new cultural heritage of Indonesia highly appreciates the local culture / traditional as well as being selective / adaptive to the current global culture / modern. We can no longer be a nation that closing down or being humble, because we aspire to be an important contributor to world civilization. To strengthen and complement the main step, then we set a number of steps supporting comprising:

- a. Sakinah Family Development and Productive
- b. Partnership development between Type
- c. Youth Leadership Development
- d. Arts and Creativity Development Populist and Religious Culture
- e. Structuring Information and Communication Channels

Family coaching is an important step that will determine the condition of society as a whole. Social acceleration that occurs as a result of modernization and urbanization are challenging family values (family values), because humans have now been boxed-boxing as a small unit of a giant machine production. Some residents have experienced alienation and social life in a cracked frame, they just appreciated the sweat and sheer skill, mental and social needs are being neglected altogether. If the condition of alienation is allowed to continue, it will bring its own turmoil, at least will increase the diversion and social vulnerability. To prevent and reduce social problems, then the condition of the family must be strengthened in a climate sakinah (peaceful), mawaddah (love) and mercy (love each other).

The family played a role as a social safety net with spur and melesatkan aspects of creative /

productive, in order to address the problems of poverty and unemployment can be started from the smallest institutions. Families are independent and empowered actually become the foundation of societal expectations, not merely the burden to be borne by the state. Pioneering youth in the social aspect (as the glue between the elements of a plural society), economic (generating entrepreneurial spirit to push the unemployment rate), politics (battering ram feudalistic and authoritarian system towards a consolidated democracy), defense (guard the sovereignty of the nation), and security (supporting social order).

Multi-faceted role that must be managed systematically through a cadre in the whole field. The energy of youth is very large, so it needs to be delivered and optimized in scholastic achievement in the arts, sports, science and technology. It was time to seriously scouted potential of young people most likely at the global level with a very tight competition system. All were intended to make this nation truly recognized his greatness, not only in terms of geographic and demographic quantitatively, but because of the superior quality of human resources.

Stability of relations between adherents of different religions will become an essential foundation for the birth of the nation's religious and civilized noble. One aspect that can not be underestimated in this era of globalization today is the management of information in a positive and open and equal communication and enlightening. In fact, it must be admitted that the development of information technology and rapid communication are the main characteristics of world civilization in the present and future. So far we become a nation of consumers against invasion of information and communications products from other countries. In fact, the unity and sovereignty of this nation that comprises thousands of islands and united with the hundreds of straits and seas, in desperate need of a solid network. Socio-cultural fundamentals that must be rebuilt as follows:

- a. Indonesian human personality is tough to face diverse challenges;
- b. A disciplined society and culture high employment
- c. Mutual trust between people of different backgrounds;
- d. High religiosity and spirituality.

The four fundamental aspects that are built through character building programs (personal disciplines), nation building (national culture), social-trust building (social cohesiveness), and spiritual purification and enrichment (/ enrichment of the soul).

## 2.2 Human Resource Development To Achieve Competitive Advantage

In order for the purpose of human resources provide a greater contribution to the organization to achieve competitive advantage needed in planning appropriate strategies in an integrated human resources. Activities of the HR strategy is based cooperation among HR departments in an integrated manner. Activities based human resource strategy of cooperation between departments with line managers and human resources management involvement in explaining the vision and mission of the organization that DAPT outlined in the strategic business objectives. Three main objectives of this strategy greatly increases the performance of present and future on an ongoing basis so as to maintain a competitive advantage. HRM strategy development process benefit the organization, namely:

- a. Defining HRM chance constraints in achieving its business goals
- b. Clarify new ideas on issues of HRM results-oriented and provide a broader perspective
- c. Perform tests of management's commitment to the activity, creating a process of allocating human resources for specific programs and activities.
- d. Focusing on long-term activities are chosen by considering the first priority for 2 or next 3 years.
- e. Pursuing a strategy that focuses on the management of HR functions and staff development are a blessing.

HR departments can create competitive advantage with four approaches, namely:

- a. Strategic partners senior manager and line managers in implementing the planned strategy, translating business strategy into action with a diagnosis in organizations, namely the assessment system (assessment) and grouping the organizational practices with business objectives that can be formed at any level of organization.
- b. Administrative Expert, Become an expert in managing the implementation work as well so that the resulting output of low cost and efficient administration. However the quality is guaranteed. This effort can be done by reengineering, including back to engineer human resources field. Become an expert administration need to master the two-phase re-engineering. First, process improvement, focused on identifying processes that are ineffective and plan an alternative method to improve the quality of care. Both think the recreation (value creation rethinking values) which the customer begins the process. So it can change the focus of work of what can be done into what should be produced.

- c. Employee Champion, to mediate between employees and management to meet the interests of both parties. With an increasingly strong business competition led to charges against the employee the higher management. Therefore line manager must consider the circumstances relating to the employee. First, reduce the demand (demand) by reducing the workload and balance with the resources owned by employees. Second, the level of resources to help employees define new resources (in the employees) so they can adjust to the needs of the organization. Third, the changing demands of a resource to help employees learn how to transform demand into the resourced.
- d. Change Agent, become agents of change, refine processes and culture that can enhance organizational capacity for change. There are three types of changes: first, the change initiative, focusing on the implementation of programs, projects or new procedures. Both the change processes within the organization by focusing on how to work together optimally. Third, cultural change will occur if the basic strategy of the business organization re-conceptualized. Fourthly it is a new role of the Department of HRM will be able to achieve competitive advantage by working with line managers and top managers.

Competitive advantage will be achieved with three strategies, namely: innovation, quality improvement as well as cost reduction. Some things that can be worn by each individual to develop himself, among others:

- a. Get to know yourself.
- b. Get to know one's own power.
- c. Get to know their own weaknesses
- d. Trying to develop interaction and open communication with the environment in a positive and educative.
- e. Getting used to always perform a self-criticism, self-evaluate, and develop a sense of humor.
- f. Trying to accept the situation rationally and objectively.
- g. Getting used to always hold checking, and meticulous in every action.
- h. Having a goal in the stages of programmed time.
- i. Not imitate yourself to someone, but erect.

The measures taken in self-development, are:

- a. Assess yourself: Get to know our strengths, our abilities, our interests and the various attributes of other issues. Consider our previous experience. Describe the results of our findings in a summary form or recording.
- b. Researching ideas and opportunities: Looking at future opportunities. Seek and consider the

relevant information. Marking sources of help and support.

- c. Making connections: Get feedback from our career development. Know your priorities and personal impulses. Combine the results of self-assessment by the choices available to us.
- d. Doing action: Write and implement a plan of activities. Communicate effectively both orally and in writing to reach the target. Review our progress and observe the aspects that need to be learned for the planning of our future careers.

Discipline and goal setting is a decisive factor in the management of our careers. Discipline make us responsible and target-setting to determine how the careers we want can be achieved. According to David Mc. Clelland there is a prominent motivational pattern:

- a. Achievement motivation, namely a desire to overcome / defeat a challenge, to progress, and growth.
- b. Affiliation motivation, namely the urge to make contact with others.
- c. Competence motivation, namely the drive to do quality work
- d. Power motivation, the encouragement that can control a situation. In this case there is a tendency to take risks and break down the barriers that occur. This property is mostly done / are the people who are involved in politics. Power motivation will not result in too bad, if followed by achievement, affiliation and competence motivation.

The purpose of motivation are as follows:

- a. Improve employee morale and job satisfaction
- b. Increase employee productivity
- c. Maintaining the stability of the company's employees
- d. Improve employee discipline
- e. Streamline procurement employee
- f. Creating an atmosphere and a good working relationship
- g. Increasing loyalty, creativity and employee participation
- h. Increasing the level of welfare of employees
- i. Heightens the sense of responsibility to employee duties.
- j. Improving the efficiency of the use of tools and raw materials

Human Resources Management have an obligation to understand the increasingly complex changes that always occur in the business environment, must anticipate changes in technology, and understand the international dimension which began to enter the business due to the fast growing information. Paradigm shift of human resource management has provided a different focus in carrying out their functions within the organization.

There is a tendency to recognize the importance of HR in the organization and focus on the contribution of the HR function for the successful achievement of corporate strategy. This can be done by integrating the company's decision-making strategy with HR functions, the greater the opportunity to gain success.

Level of integration between strategic planning with HR functions are manifested in four kinds of relationships:

- a. **Administrative Relationships**  
Here top managers and functional managers with other regarded HR function is relatively unimportant and saw man not as a limitation as well as assets of the company in making business decisions.
- b. **One Way Relationships**  
There sequential ties between strategic planning with HR functions. HR function design programs and systems to support corporate strategic objectives. So the HR reaction of strategic initiatives but has no effect, because even though it was considered important but not yet regarded as a strategic business partner.
- c. **Two-Way Relationship**  
Characterized by reciprocal relationships and interdependence between the human resource strategy planning. HR function is deemed essential and can be trusted. HR plays a role in determining the company's strategic direction and has become a strategic partner.
- d. **Integrative Relations**  
Characterized by a dynamic and inter-relationships between the active HR functions and strategic planning. Here, the HR manager is seen as truth staregis and business partners involved in strategic decisions.

Associated with the development of integrative relationships, it can be done with due regard, a few things, namely:

- a. **Environment:** The Power of an environment that was instrumental in carrying increased competition, technological changes and changes in labor femography
- b. **History and culture of the organization:** organizational culture that oriented on a strong human resources capable of developing a natural relationship between human resource activities with strategic planning.
- c. **Strategic:** Strategies focusing on one type of core business can boost the potential for the creation of relations of strategic planning with human resource is increasingly integrated because it allows the development and implementation of programs and human resource systems across the agency,

- d. **Structure:** The placement of units of human resources in organizational structure, senior human resources executive was given the same status as other functional directors
- e. **The skills and values espoused executive:** human resources have a good knowledge of business and are able to provide input into the strategic planning process.
- f. **Skills and Values Employee owned:** HR functions received aid management to solve the employment problem will reinforce the importance of HR functions.
- g. **Management System** which includes reward systems, communication systems and human resources so that human resource information and planning strategies will be more integrated if the senior executives have a substantial percentage of compensation bear the risk.
- h. **Communications systems** that have the goal of building awareness of managers of the company's strategic tujaun and encourage them to encourage their subordinates to develop the motivation of human resources database is supported with a well-developed.

Referring to the above description, that one of the development of integrative relationships are through the environment. Learn about the environment, of course, we must understand the system of environmental management All human activities have an impact on the environment. With the development of economic activities and technology that gives him the ability to perform engineering and increase energy use. Our attitudes and behavior towards environmental stimuli are dominated by economic considerations, sometimes even excessively so as to encourage the exploitation without being followed by an adequate protective measures.

Such behavior is also influenced by the lack of knowledge or lack of respect for the ecological functions of the environment that provide services to humans, resulting in damage to the environment. For that we need to change our attitudes and behavior to be environmentally friendly behavior. Changing attitudes and behavior is not an easy job. Environmental management systems are now recommended are the System of Self-Set. Regulate itself is certainly not in an absolute sense. The government still has authority to supervise and regulate.

With the growing democracy and education, the public would be more able to conduct surveillance. ADS is the meaning more people have a responsibility to maintain compliance and law enforcement. ADS has begun to evolve in the Indonesian business world, for example, many companies are trying to get ISO-14000. For example the chemical industry in Indonesia has begun moving toward the ADS which is the

practice of voluntary environmental management association international chemical industry.

The key to the success of the business world in the application of ADS is to change the view of the environment as external factors of business becomes an internal factor of business. Internalization of the environment into business strategy opens the possibility for development of an integrated business environment. This view is diametrically opposed to the common view that the internalization of environmental life gives bad impact to business because businesses have to bear the environmental costs currently charged to the environment and society.

### 3. Conclusion

Based on the description of material mentioned above, especially regarding the definition of qualified national character development and human resource development in order to achieve competitive advantage, it is expected that the more insightful character development in acts the various issues of nationality and weak human resource capacity, as well as the existing environment. Thus, it can be more wise and prudent alternatives provide solutions to overcome the problems of nation and character building management.

### REFERENCE

- [1] Dewey, J, *Democracy and Education: an Introduction to the Philosophy of Education*, The Free Press, New York. 1916.
- [2] Menteri Pendidikan Nasional 2006b, *Peraturan Menteri Pendidikan Nasional nomor 23 tahun 2006 tanggal 23 Mei 2006 tentang standar kompetensi lulusan untuk satuan pendidikan dasar dan menengah*.
- [3] Suryadi, Ace, *Pendidikan, Investasi SDM dan Pembangunan*, Balai Pustaka, Jakarta , 2002.
- [4] Barthos, Basir, *Manajemen Sumber Daya Manusia*, Bumi Aksara, Jakarta, 2001.
- [5] Djojonegoro, Wardiman, *Pengembangan Sumberdaya Manusia Melalui Sekolah Menengah Kejuruan*, Balai Pustaka, Jakarta, 1999.
- [6] Gary Dessler, *Human Resources Management*, 9th edition, Prentice Hall, 2003.
- [7] Sarwono, *makalah Nation and Character Building*, Jakarta, 2010.

## BUILDING CHARACTER AT VOCATIONAL HIGH SCHOOLS STUDENTS FOR READINESS OF WORK IN INDUSTRY

**Siti Mariah**

Indonesia University of Education  
sitimae\_1204@yahoo.co.id

### **Abstract**

This study aims to find a learning strategy in vocational high schools (VHSs) which is effective to develop character students to work for garment industries. The initial idea was the main purpose of VHS is to prepare students to work according to their expertise. This study employed the research and development design. The research subject 122 students of VHSs dressmaking study program in Yogyakarta. The instrument validation employed the confirmatory factor analysis and the reliability was assessed by the cronbach's Alpha. The fit of the model was tested by means of the path analysis in the Structural Equation Modelling using the LISREL 8.71 software.

The result of the study are as follows: (1) The strategy for the process effective to develop character among VHS students consists of 5 process steps, ie. work commitment construction, work ethic doing simulation, work appreciation, work culture practice, and reflection. The strategy fit to develop character VHS students, indicated by a p-value of  $0.161 > \alpha = 0.05$  and the result of goodness of fit index; RMSEA =  $0.034 < 0.08$ , CFI =  $0.990 > 0.90$ , and AGFI =  $0.847 < 0.95$ , showing that the strategy has empirical support and fits to use in VHSs. Work culture is a variable intervening of motivation, commitment, work ethic and appreciation of students' work readiness. There are twelve aspects that reflect the work readiness. The highest scores ( $>3$ ) occurred in the aspect of self-confidence, discipline, and competitiveness. All aspects such as job readiness score at 2.9, it can be said is close to 3 so that is strong enough to be accepted as an indication of the readiness of the work that has been pretty good.

**Keywords:** character, work, students, vocational high schools (VHSs)

---

### **1. Introduction**

The main objectives vocational high school is to prepare students primarily for work in a particular field (UUSPN, chapter 15), but the Central Statistics Agency (BPS) figures show unemployment in August 2008 based vocational education is dominated by graduates of 17,26%, followed by high school graduate as 14,31%, and university as 12.59%. This is an indicator that vocational education has not been able to produce graduates who are ready to work.

The role of education in producing graduates who meet the qualifications required by the world of work is still doubted by the world of work. Vocational school graduates who have passed the competency test and have a certificate, but at the time of entering the workforce can not follow the system of industrial employment. As a result, many graduates are not absorbed into the world of work and unemployment. One of factor, unable to adapt to the working system, unable to work, unable to work in teams, or no mental resistance in the face of pressures and frequent low bargaining position in the world of work.

Based on the search results on-line recruitment garment export-oriented manufacturing in Indonesia, the terms most frequently raised for

prospective employment in the production line is able to work with high-pressure jobs, able to work overtime, able to be placed in the production area and able to work to achieve target set time, physically and mentally healthy, no glass eyes, even for operators that can not be sewing for the sewing will be trained (<http://acecnews.blogspot.com/2008/03/Ungaran-sarigarment.html>).

Competition global workforce increasingly tight and competitive, the impact on human resource needs that can run the production system in accordance with market developments for survival in the arena of world trade. Working in the garment industry should have a character that could work to the rhythm of work and fast with high productivity (output per minute piece), is mass production with the production of conveyor systems, and product quality are very closely guarded. Mental readiness and physical endurance is good to support the smooth working of its workers must possess to be able to produce clothing with a fast, precise and quality. Technical capabilities that are reliable and proficient if a character does not have a good working then it becomes meaningful to work in the industry.

This study focused on building work character for vocational students courses fashion expertise to

be ready to work in the garment industry, and examines the implications of the model to the relevance of vocational school graduates with the garment industry demand. Components or aspects that are reviewed to support the model of character development of students' vocational work is a working system that is used in the industry were adopted in the teaching practice in schools, that is "Kaizen" which includes: work attitude 5S (short, straighten, sweep and clean, systemize, standardize), quality control (QC), and just-in-time (JIT).

The main objectives to be achieved in this study is to obtain models of the character development of students' vocational work areas of expertise clothing to be ready to labor in accordance with the demands of work in industri Garments. Characteristics of the model include: (1) integrated in the practice of learning to sew, (2) can be used starting from level one, two, and three in each semester, (3) character work continuously, resulting in habituation and shaping work culture; (4) character of the work that was developed based on work in industrial systems that implement kaizen is working attitude 5R, QC, and JIT.

## 2. Work Character Building

The characters are often given an equivalent character, disposition, temperament or character. Character is the way of thinking and behaving that characterize each individual to live and work, both within the family, community, nation and state. Individuals who are good characteristics are individuals who can make decisions and ready to take responsibility for any consequences of the decisions he made [1]. Character is the values of human behavior associated with the almighty god, self, fellow human beings, the environment, and nation hood embodied in thoughts, attitudes, feelings, words, and actions based on religious norms, law, etiquette, culture, and customs [2].

Character as a spiritual self, which appears in the overall attitude and behavior are influenced by talent, or potential in themselves and the environment [3]. Thus the character is a special quality of a firm and (differentiator) formed in the lives of individuals that determine the attitude of holding a reaction to stimuli with regardless of the circumstances. However, to develop character, necessary 'character coach' or 'character mentoring' that direct and inform mistakes and weaknesses of a person's character [3].

Character is the value which was engraved in a person that was formed through a process, education, experience, experiment, sacrifice and environmental influences, the intrinsic value of the underlying attitudes and behavior. One of the key points of the educational task is to build students' character. The forms of the characters have been

formulated differently developed. Indonesia Heritage Foundation formulate some form of characters that must exist in every individual of whom the Indonesian nation; love to God and the universe and its contents, responsibility, discipline and self-reliant, honest, respectful and courteous, affectionate, caring, and cooperation, confidence, creative, work hard and never give up, justice and leadership, good and humble, and tolerance, love peace and unity. Meanwhile, character counts in the U.S. indicates that the characters become pillars are: trustworthiness, respect, and respect, responsibility, fairness, caring, citizenship, honesty, courage, and integrity.

Character development work in vocational schools, requires learning approaches to suit the needs of the world of work for effective results. Fostering working character of learners does not mean adding new subjects, but to give value and meaning to learning. The essence of education is to humanize humans. The man who will live in the midst of interacting humans and the environment in harmony. Thus the five pillars of learning leads to the educational development strategy that is, learning to know (knowing more), learning to do (doing best), learning to be (being better), and learning to live together (living in harmony)(<http://www.unesco.org/en/esd/strategy/>).

The tools used to build the character of industry-based work on the program expertise of fashion is the application of 'kaizen'. That is a Japanese strategy of continuous improvement which is a fundamental principle of lean manufacturing concepts that became a management concept applied throughout the world. Kaizen as well as a phased approach in a systematic, sustained, and in accordance with the achievement of targets. One of the most effective tool in continuous improvement is the concept of 5S in conducting waste reduction stages. It is an effective method in creating an ideal working environment where the work environment has a profound impact on the quality and productivity [4], that is; seiri – short, seiton – straighten, seiso - sweep and clean, seiketsu - systemize, shitsuke - standardize.

Cleanliness, comfort and freshness of the workplace have an influence on human motivation in work 5S is an effective means to improve the basic mentality of the workers, including ways of thinking and acting in the execution of daily work and attitudes that support the implementation of enterprise management system [4]. The character development work may be used for each implementation of learning the practice and can assist teachers in improving the culture of learning toward an approaching work culture in the industry. Teachers demanded a role as a supervisor and quality control, both during the learning process and in assessing the product of student practice. Shape the character of work in vocational



guidance with the implementation of standards will be more extensive time needed for all aspects of production use today are not only based on the quality and quantity, but also the standard time that can meet customer satisfaction.

Fostering character learners work to be done gradually and continuously in accordance with the level of physical development, social, and psychological students. Resulting in the learning process of habituation. According to the theory Proser and Allen: (1) efficient if the environment in which students are trained to do by the way, tools, and the same machine as required in the job, (3) effective if trained habits of thinking and working like in the DU- IN, (4) effective if training and work habits to form the correct habits of thought is repeated so as to suit/fit the job, (5) effective if teachers have a successful experience in the application of competencies in operations and work processes that have been made, (6) in every

position there is a minimum capability criteria to be owned by someone so he can work on the job, (7) vocational education should attention to market demand.

Method of character development to implement industry-based work simulation work practices in the learning process. Students can build confidence, recognizing its ability to do a job; Students are responsible for the work being carried out to completion; Students disciplined with time; Students have a high fighting spirit, and have the mental resilience of employment in accordance with the needs of the working world. Learning in vocational setting as a miniature of the industry demanded the teacher's role is more flexible. It is based on the premise that every student has the opportunity to work in the industry. Character development strategy that integrates the work of students in learning the practice described in the figure 1.

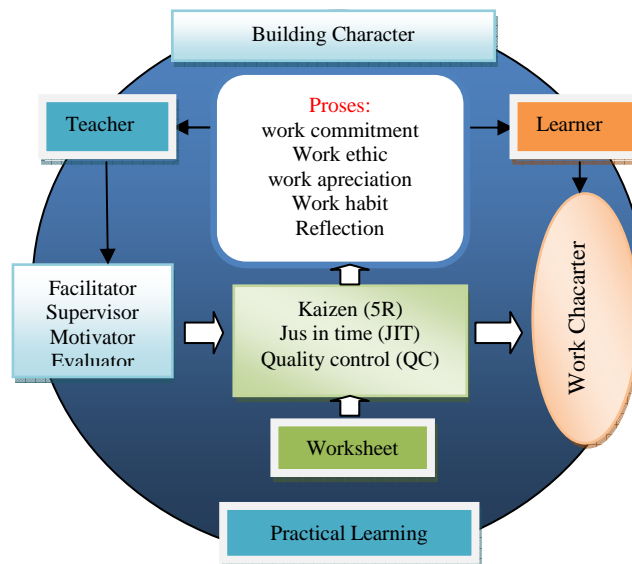

Figure 1. Building Character Model

### 3. Research Methods

#### 3.1 Confirmatory Factor Analysis (CFA)

CFA is used to test a concept that is built using several measurable indicators. Test the suitability of the confirmatory model was tested using goodness-of-fit Indices that include chi-square, probability, RMSEA, TLI, GFI, CFI dan CMIN/DF.

Counting analysis using LISREL software program 15, with the assessment criteria  $>0.50$  charge factor is very significant, but if still  $>0.30$  those items can still be considered for use. This study used a large cargo factor  $>0.4$ , if the load factor  $<0.4$  those items are not measuring the indicator and be disqualified. Other criteria that basis is if the value of  $t$  values  $>1.96$  and black can be said indicator

is valid and fit for use, otherwise if  $t$  values  $<1.96$  and red should be eliminated because it can not reflect the indicator [3].

Analysis of Structural Equation Models (SEM)

SEM used in this study to determine the effect of latent variables exogenous; job commitment, work ethic, motivation and appreciation of the work of the endogenous latent variables; work culture and work readiness. Analysis of the structural equation model using LISREL 8.71 program assistance. The criteria set for getting fit model is the overall size of the instruments carried by the goodness of fit index. Indicators for assessing model fit among other indicators are based on: (1) Root Mean Square Error of Approximation (RMSEA)  $\leq 0.08$  indicate good fit, (2)  $p$ -value  $\geq 0.05$ , (3) Goodness of Fit Index (GFI)  $\geq 0.9$  &

GFI 0.80, 0.90 marginal fit, (4) Adjusted Goodness of Fit Index (AGFI)  $\geq 0.90$  &  $\leq 0.80$  AGFI, 0.90 marginal fit, and (5) Comparative Fit Index (CFI)  $\geq 0.90$  normed Fit Index (NFI)  $\geq 0.90$  [6]

#### 4. Research Results and Discussion

##### 4.1 Results of the test construct validity by CFA

The model developed builds work character involving a variable: work commitments (x1), work ethic (x2), appreciation of work (x3), the work culture (x4), motivation (z) and work readiness (y). Viewed the work readiness of intrapersonal aspects, namely: self-confidence (y1), responsibility (y2), discipline (y3), mentality (Y4), honesty (y5), power struggle (y6), and compliance (Y7). Manifesto of the interpersonal aspects of competitiveness (y8), adaptation (y9), communication (Y10), cooperation (Y11), and leadership (Y12).

The results of data analysis described in three parts: 1) The test instrument to determine the feasibility of the questionnaire used, 2) data

description to describe the characteristics of the study variables, and 3) Test SEM to evaluate the acceptance of respondents to the model, and prove whether the model can work affect job readiness .

##### 4.1.1 Internal Validity

The evaluation of the ability to manifest in reflecting the latent variable were tested with confirmatory factor analysis (CFA). His ability demonstrated by the coefficient lambda-owned, and meaning as manifest by the t-count. The higher value reflects the stronger the signal of lambda, and the higher the t-calculated value indicates the more meaningful or significant. Manifest latent confidence (table 1) has a lambda value of 0.68 and a t-square 5.39 count lambda  $0.68^2 = 0.4624$  (46.24%) describes the contribution of reflected self-confidence. While the acquisition of t-count of more than 1.96 indicates significant [4]. So the first declared invalid manifest with 46.24% contribution.

Table 1. Testing Results CFA Latent Confidence

Variabel	Manifes	lambda	t-hitung	Keterangan
Confident	Y1	0.68	Ref	significant
	Y2	0.72	4.84	significant
	Y3	0.58	6.45	significant
	Y4	0.61	6.20	significant

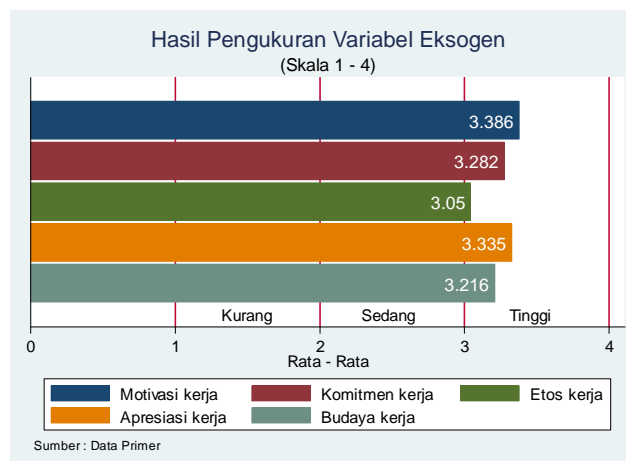

Figure 2. Histogram Comparison Average Exogenous

The highest score is the work motivation, whereas the lowest score is the work ethic, followed later work culture, job commitment, work appreciation. So aspects of sincerity, thoroughness, enthusiasm, spirit and optimism in seriousness, the superior work gets priority for improvement. The second priority is the cultural aspects of work: cooperation, just-in-time, quality control, honest and 5S attitude.

Student responses can also be explained individually through categorization. Distribution of responses obtained in the variable work motivation: as much as 81.15% of students categorized scores high motivation, the other quite as much as 18.85% categorized. Not found scores of students who lack motivation or low works. Variable work commitment and appreciation of the work also has a characteristic distribution with a majority of the high category, the work commitments 65.57% and

62.30% appreciation of the work. Thus the motivation, commitment and appreciation of work, a high response in the aggregate, and students give a high response. Variable work ethic and work

culture of the majority, as much as 67.21% in the variable work ethic, and 52.46% in the work culture.

Table 2. Testing Results CFA Latent Confidence

Variabel	Manifes	lambda	t-hitung	description
confidents	Y1	0.68	Ref	Significant
	Y2	0.72	4.84	Significant
	Y3	0.58	6.45	Significant
	Y4	0.61	6.20	Significant

The manifest also declared invalid the other latent signified by the t-count of more than 1.96. Means that all manifests are used to reflect the latent proven to function properly, so it does not do the removal or replacement of the manifest in the questionnaire.

#### 4.1.2 Construct Reliability

The manifest can be viewed as a form of operational indicators that reflect a latent variable, so that conceptually manifest latent in a set of measuring the same universe. However universe or nature unidimensi. However, the empirical level, this similarity is not necessarily agreed upon by the participants, and he viewed not as unidimensi.

Empirical evaluation of the nature-manifes to unidimensi can be done based on a latent construct reliability coefficient  $\geq 0.7$  signifies the acquisition is unidimensi or reliable. The results of the calculation of the confidence variable reliability coefficient values obtained for 0744, the acquisition is  $\geq 0.7$  signifies unidimensi or have an acceptable construct reliability. Manifesto of the other latent variables also have construct reliability coefficient  $>0.7$ , indicating that unidimensi be declared reliabel. Based on these results, all the sub's

manifest variables declared readiness work reliable in measuring its latent.

#### 4.1.3 Testing Descriptive

Scores the answer is the response of participants against some proposed variables, namely: work commitment, work ethic, appreciation of work, work culture, motivation, and job readiness. In general, the higher scores indicate better, and the lower the mean the opposite. In accordance with the scale of the answers are used, scores will be in the range 1-4.

##### 4.1.3.1 Exogenous Variables

Scores of variables measuring work commitment between 2,32 – 3,80 with an average of 3,28. 2,32 is the result of the lowest scores of all participants was measured on a scale of 1-4 interpret the respondents with the level of motivation to work less than moderate. While 3,80 is the highest yield scores that show the presence of respondents with high motivation. The average for  $>3$  shows in general of all respondents already have a high motivation to work. The results of measurements on other exogenous also obtain the mean scores on all 3.

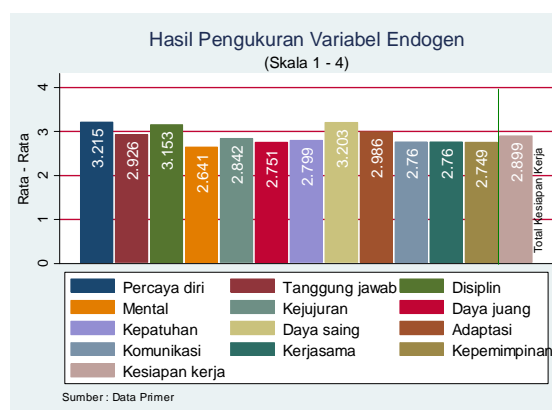

Figure 3. Endogenous Variable Histogram

The majority of participants have a job readiness categorized simply by the amount reached 68.03%, the next largest categorized as 16.36%

less, then high-low as much as 13.93% and 1.64% (see table 3).

Table 3. Distribution of Work Readiness Response

Kategorisasi	Frekuensi	Frekuensi (%)
lower	2	1.64
lower	20	16.39
midle	83	68.03
high	17	13.93
Total	122	100.0

#### 4.1.4 Data Validation

##### 4.1.4.1 Normality

The data distribution was evaluated by kai square test, for variables of work motivation coefficient obtained for 0047 with a probability of 0.977, the acquisition of  $\geq 0,05$  p denotes normally distributed data. Normality is important because it means that analysis results can be generalized to the population, and can also be used as a parametric statistical tools. Kai squared test result for all outcome variables have kai squared with probability more than 0.05, indicating all the variables have the data with normal distribution.

##### 4.1.4.2 Multicollinearity

The relationship between variables in the model that was developed to put the variables of work motivation, job commitment, work ethic, appreciation of work, and work culture as exogenous mutually independent. Means no harmful relationships (multikolinier).

Evaluation to see relations between exogenous forces is done with the product moment correlation test, in the table 4 are shown the correlation of  $<0.8$ . The small correlation coefficient its shows the relationship between exogenous is not strong, so that otherwise does not occur multicollinearity [5].

Table 4. Multicollinearity Test Results

Variabel	Work commitment	Work ethic	Work appreciation
Work motivation	0.068	-0.037	0.158
Work commitment		0.120	0.168
Work ethic			-0.089

##### 4.1.4.3 Outlieritas

Relatively always found any data values that are far from reratanya or outlier. Its presence causes the data quality decreases and its distribution is not normal. Normal result in previous testing indicate that there is still outlieritas be tolerated because it does not cause the data is not normal.

##### 4.1.5 Compliance Test Model

Suitability model to evaluate the matc between the sample covariance with population, if the results are appropriate means empirically supported models

so that no changes or modifications required. However, if otherwise is necessary modifications. One marker that indicates the suitability of this is chi square coefficient. From the test result obtained coefficient chi square of 224.60 with a probability (p) of 0.000, the acquisition of  $P < 0.05$  showed no significant differences between the sample covariance with a population that otherwise the model is less suitable. Chi Square is an absolute fit index, which is sufficient basis to modify the model, for other GOF parameters can be seen in the following table 5.

Table 5. Goodness of Fit Index Results Models Before Changes

No	Index	Cut of Value	Result	Description
1	Kai Kuadrat (p)	small ( $p > 0.05$ )	224.60 ( $p=0.000$ )	No fullfiled
2	CFI	$\geq 0.90$ (max 1)	0.944	fullfiled
3	GFI	$\geq 0.95$ (max 1)	0.821	Moderate
4	AGFI	$\geq 0.95$ (max 1)	0.748	Moderate
5	RMSEA	$\leq 0.08$ (Min 0)	0.094	Moderate

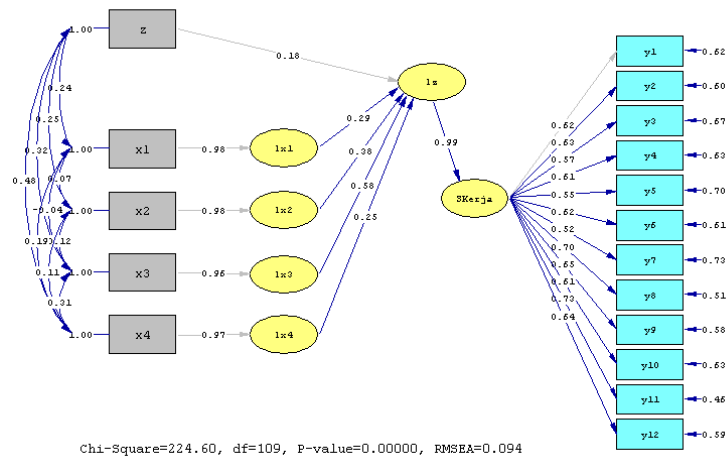

Figure 4. Building character model before changes

Structurally not made major changes to the hypothesized variables, the only change to the manifest error of the endogenous variables.

Chi square value becomes 117.16 after repair model with probability (p) for 0161, changes the probability (p) probability (p) becomes more than

0.05 indicates a significant difference no longer occurs between the sample covariance with the estimation, means that the proposed model received strong support from the sample to explain or population estimates [6].

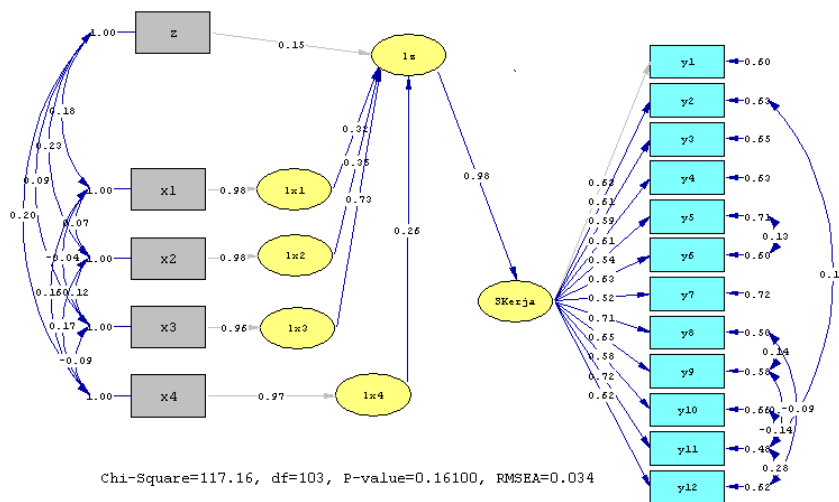

Figure 5. Building character model after changes

Table 6. Goodness of Fit Index Results Build Character Model After Changes

No	Index	Cut of Value	Result	Description
1	Kai Kuadrat (p)	small (p > 0.05)	117.16 (p=0.161)	fullfiled
2	CFI	≥ 0.90 (max 1)	0.990	fullfiled
3	GFI	≥ 0.95 (max 1)	0.897	moderate
4	AGFI	≥ 0.95 (max 1)	0.847	moderat
5	RMSEA	≤ 0.08 (Min 0)	0.034	fullfiled

#### 4.1.7 Structural Test Results

Test results in the above figure is displayed again in the table 7 below. The first function in the

model is  $z = 0.3186x_1 + 0.3528x_2 + 0.7264x_3 + 0.2625x_4$ , while the second function is  $y = 0.9833z$ .

Table 7. Functions In Model Building Character

Fungsi	Endogen	Eksogen	$\beta$	$\beta^2$	t-val	Ket*
1	Budaya Kerja (z)	work motivation (x1)	0.3176	10.09	2.6946	Sig
		work commitment (x1)	0.3528	12.45	2.7074	Sig
		work ethic (x1)	0.7264	52.77	3.0143	Sig
		work appreciation (x1)	0.2625	6.89	2.5550	Sig
2	Readiness to work (y)	work culture (z)	0.9833	96.68	2.9589	Sig

\* T-val  $\geq 1.96$  : Significant

The first function explained that the culture of student work can be explained by exogenous (motivation, commitment, ethics and appreciation). Positive beta coefficient indicates if the exogenous variables can be well managed so that the increase, workplace culture can encourage students to become better. All exogenous variables have a t-value of more than 1.96, indicating significant in influencing the work culture. Greatest contribution is the work ethic with  $\beta = 0.7264$  (52.77%), variable work commitment with  $\beta = 0.3528$  (12:45%), work motivation variables with  $\beta = 0.3176$  (10:09%), and it recent appreciation of the work with the variable  $\beta = 0.2625$  (6.89 %).

The second function is the equation  $y = 0.9833z$ , this function shows the readiness of the student's work (y) can be explained significantly (t-val  $\geq 1.96$ ) by the work culture (z) owned by students. Great job readiness that can be explained is  $0.9883^2 = 0.9668$  (96.68%). The model was developed put the variable work culture as intermediate variables (intervening) of motivation, commitment, work ethic and appreciation. Analysis of the ability to work as an intervening culture can be done through the significant exogenous to the work culture and work culture of work commitment. All relationships between variable are significant, meaningful work culture proved to be intervening in the model.

## 5. Conclusion

5.1 Build work character integrated learning practices with the five phases: (1) building work commitment, (2) work ethic simulation, (3) appreciation of work, (4)

practical work culture, and (5) the effective reflection develop programs for vocational students, based on: the fulfillment of the character dimensions of work and implemented a very effective process stages.

5.2 Overall stages and the building work character foster good working readiness on on intrapersonal aspects of skills, including self-confidence, responsibility, discipline, mental toughness work, honesty, competitiveness, and aspects of interpersonal skills include the power struggle, adaptation, communication, cooperation, and leadership.

## REFERENCE

- [1] Suyanto. Tantangan pendidikan hadapi globalisasi. [www.kompas.com/](http://www.kompas.com/), 16 mei 2001
- [2] Hari Suderajat. Implementasi kurikulum berbasis kompetensi (KBK) pembaharuan pendidikan dalam undang-undang sisdiknas 2003. Bandung: Cipta cekas grafika, 2004
- [3] Doni Koesoema. Tiga matra pendidikan karakter. Majalah BASIS, agustus-september 2007.
- [4] Imai, Masaaki Gemba kaizen. Pendekatan akal sehat, berbiaya rendah pada manajemen. (Transl: kristianto Jahja). Jakarta Putaka Binaman Pressindo, 1998
- [5] Imam Ghozali & Fuad. Structural equation modeling. Semarang. Badan Penerbit-UNDIP, 2008
- [6] Jöreskog, K.G., & Sörbom. Lisrel 8: User reference guide. Chicago: Scientific software International, 1996
- [7] Gujarati, Damodar. Basic econometrics. New york: McGraw-Hill, Inc, 1995

# PART TWO

Organization: The Challenge of Vocational  
Education in the Changes of Technology

# VOCATIONAL EDUCATION AND KNOWLEDGE COOPERATION IN PROFESSIONAL CONTEXTS. EUROPEAN EXPERIENCES WITH NEW TECHNOLOGIES

**Prof. Dr. Thomas Köhler**

Technische Universität Dresden  
thomas.koehler@tu-dresden.de

## Abstract

Social Software applications have raised expectations in the context of all forms of education, including school and higher education but also vocational education. Assuming that learners today are increasingly used to online communication, E- Learning researchers have envisioned how social software could stimulate forms of online learning that are more motivating and engaging than those afforded by traditionally established off- and online-learning systems.

In the context of vocational education and training the so-called communities of practice (COP) are expected to play central roles in this process, allowing learners to group around specifically collected and shared information and resources. A central aim of such developments is to connect learners and staff by crossing the margins of vocational schools, enterprises but also private households. Experiences with social software used in formal contexts indicate however that students' media competence is less developed than required for the new learning practices and that students perceive their online learning spaces very differently from their personal online spaces. These observations call into question the application of social learning in formal contexts of higher education.

This paper takes an empirical approach to identify the potential role of web2.0 based social learning in vocational and professional education. Departing from the assumption that such education and training is too often equated with formal learning, it presents the results of ongoing research into the challenges vocational and work related education poses to students beyond their courses and into the informal learning practices (and social software applications) students employ to cope with it. This approach of purpose-related learning together with the empirical insights into actual learning practices will help to elaborate social learning as a methodical-didactical concept and to specify its role in bridging the gap between formal and informal learning in vocational education and training.

**Keywords:** Project based laboratory

---

## 1. The status quo in vocational education versus continuous professional training

Continuous training is one of the most rapidly growing sectors of education and has become even stronger under the label of life long learning in Europe (cp. Frindte et al., 2001; El-Gamal & Köhler, 2009). However, it appears that vocational education learning contents and as well as study contents hardly meet the operational specifics of work-related training where rather short periods of training activity are needed. This observation is also applicable the most forms of planned, formalized staff development. For the corporate practice of increasing importance is a more problem-oriented work, combined with a fast and mostly informal and finding of solutions. To meet such a target we may address the exchange within knowledge communities that follow the concept of the so-called Community of Practice (CoP).

## 2. Empirical findings: the design of sustainable interventions into vocational education practice

Our research projects aim to promote social interaction between learners and to encourage the building of communities of learners and teachers in vocational education but also of practitioners who are located at different places but need to exchange knowledge and information, i.e. create a joint learning experience – similar to what has been described by Lave and Wenger (1991) and is funded by the German Industrial Safety Board (2004 – 2011) plus the Federal German Ministry of Education and Research (2009 – 2012) and several scholarships. Methodically this research is achieved through several empirical steps as case studies, online surveys and usability tests.

### 2.1 Case study on initial vocational training: The online training certificate as web 2.0 method

To demonstrate the application of new technologies and new opportunities in the field of vocational training we present the online training certificate as an example. This is not an application for the vocational educational and training in the



traditional sense of teaching and learning. Rather, it is an application that will improve the organization and documentation, and the way how we deal with the reflection of the educational and training process.

The online training certificate was developed within the R&D project „Online record book for strengthening the place of learning cooperation” (<http://www.blok-online.org/>) and is currently sponsored by the Federal Ministry for Education and Research within the context of the national programmed „Web 2.0 in Vocational Education”. In the center of the project stands the re-development of our existing instrument, a paper-based training certificate book, with the help of innovative online communications technologies. Primary objective is to strengthen the cooperative learning location between businesses and schools through a unified and common information base. Overall, the online record book links all stakeholders participating in the vocational education scheme, including students, teachers, vocational trainers and members of the examination committees at the chambers of trade.

The online record book is the digital conversion of paper-based form of the report booklet in a Web 2.0 application that can be used anytime, regardless of current place of learning of the trainee. As usual with the classical form of report specifications, the trainees also document in the web form on a regular basis the temporal and material process of its apprenticeship. The special feature is the virtual representation of the entire process of using the record book. This means that not only the time and location independent performing and reading the report booklet is made possible through the online training certificate, but also the (legally binding) acceptance of the report issue by the instructor and the transfer of the record books contents to the examiners in the respective chambers and guilds.

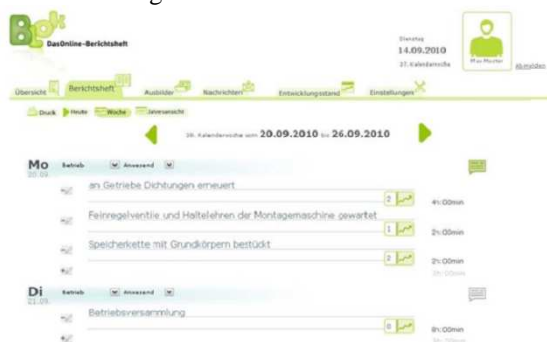

Figure 1. Implementation of the report in the online record of formal qualification

Main goal is the reliable collection and presentation of subject specific competences in the context of the vocational training. The measure of professionally applicable, well-trained competencies is based upon the trainees initially assignment in the record book. Here the entries are

linked to so-called qualifications, i.e. vocational training positions from the regulations, which are stored in the system according to the professions temporal and subject related structure. This assignment active reflection of the training content edited by the trainees and can thereby strengthen their ability to reflect their own vocational development.

Captured by the accumulation in the record book and the professional profiles positions assigned work or study hours in each area, the corresponding actual state is represented as achieved by the trainees. With the target / actual status indicator both the trainees and trainers are able to identify whether the trainee has worked according to training policy / curriculum at the particular time and on the necessary activities to a sufficient extent. Through the resulting transparency differences may be easily detected and corrected by the student in a mostly self-determined way.



Figure 2. screenshot of the development portfolio

Figure 2 shows a screenshot of the development portfolio presented in relation to the job description for each position of activity as defined by the training regulations and, secondly, its completion measured by the amount of workload completed in % of the overall amount demanded.

## 2.2 Case study on informal vocational knowledge exchange: A community of practice for industrial safety experts

The concept of the “community of practice” is gaining greater interest in the education field because the role which communities may play in assisting employees construction of knowledge and supporting transformation of their practice through group discussions and sharing of knowledge (Putnam & Bork, 2000). Therefore, it should be an emphasis on providing opportunities for employees to participate in professional communities – also going beyond organizational margins. The term “community of practice” is advocated by Lave and Wenger (1995) as they describe it as a set of relationships between persons, activity and their world over time and in relation with other tangential and overlapping communities of practice.

Our solution developed for a Germany wide working professional group of industrial safety experts is a community (<http://www.sifa-community.de>) based upon an online tool. This is allows to offer continuous support and communication for safety experts in everyday work settings. Typically this group is distributed among different enterprises or originations, working on safety issues only part time besides other duties. Safety reacted exchange with other professionals is hindered by the lack of availability of another safety expert on the same organizations in many cases. Thus face to face exchanges needed to be organized in form of extra work activities with quite some effort only.

The community emerged as a subproject of a longtime study the community is online since 2005 (cp. Hamper et al., 2005). Since then a growing number of participants network with each other. On the other hand a number continuous education activities of these professionals for work safety is triggered by their participation in the online community of practice in a non-formal way. Since 2010 new safety experts get an introduction of how to adopt the community for individual training needs already during the formal safety education. Currently the Sifa-Community (<http://www.sifa-community.de>) has become a valuable online offering to support the continuous development of safety professionals' competence in everyday working life (funded by the German Statutory Accident Insurance; cf. Trimpop et al., 2008; Kahnwald et al., 2008). The community went online a one-year design phase in May 2005 with the goals to network the participants of the long-term study with each other and to allow a continuous activity-related training of these industrial safety professionals.



Figure 3. Sifa-Community (<http://www.sifa-community.de>)

Since the launch of the community participant numbers have increased rapidly. Besides the great confidence in Web 2.0, reasons are definitely the topic and the fact that usually only one specialist for occupational safety exists who needs to

overcome the borders of its company to network with other professionals in a non-physical way. Especially in 2008 and increase of registered users by around 50% emerged - now the Sifa-Community is used by more than 3,000 professionals working for the improvement of industrial safety offered. With increasing numbers of users we could also observe enhanced peer-to-peer activities among the participants, which may be interpreted as an indication off the high acceptance of the offer.

A key feature of the Sifa-Community is the opportunity off using the forums. Here we may confirm that with 16411 almost all (98%) off the than 1676 users observe at least one forum for reading and thus receive a daily e-mail notifications about new posts. In almost all cases it is the forum "SSOS - questions and problems". Only 25 users (1.5%) have not subscribed to this forum. More than one forum is observed only rarely.

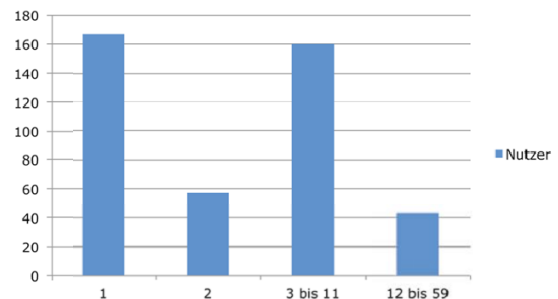

Figure 4. The frequencies of authorship in The Forum

Figure 4 shows the frequencies of authorship in The Forum: 52% of the 427 authors have posted one or two Messages too their colleagues. 38% have even written 3-11 articles, but only 10% (43 people) have left 12-559 posts in the forum.

The rationale for the use of the Sifa-Community should analyzed by an evaluation of the community in the period December 2008 to January 2009. For this purpose, the use of statistics (analysis off collected usage data on the server side), the forums and user profiles data (analysis of the observed forums) and evaluated the number of stored contacts, and written posts. These data were supplemented by statements from an online questionnaire. It was found that information gathering and problem solving with 63% with 62% are the main motivations in order to use the community. "Technical assistance" represents for 60% of respondents a further important aspect of using the platform. The community serves mainly the informal learning in order to solve individual or local problems, obtain the latest information and network with other professionals. Unlike some other job-specific online communities the use of the SIFA community is less in leisure time for exchange, but rather as a working and information tool during working hours. The aspect of entertainment which is often in relation to other web services is hardly relevant to the respondents.

Also training in the classical sense is less important for the use of the community.

### **Outlook: consequences of new patterns of learning and information exchange in the vocational context**

The influence of new digital and online media technologies in vocational education and training is far-reaching and complex. The specific configuration of VET at the interface between general education and work, but also its extension into the sphere of life long (professional) learning leads to specific outcomes (Köhler, 2006). In the following some major outcomes shall be described in a thesis like manner:

1. Competencies are needed to adopt technologies: Both main target groups, teachers and pupils, have a specific repertoire of experiences to adopt media technologies. Research shows that their daily experience with web 2.0 and online learning differs a lot and needs to be taken into account specifically to allow a successful and self-motivated adoption of such technologies.
2. Learning conditions in the vocational context: In many national vocational education systems education takes place at two different locations, in the vocational education school and in the industrial plant. Both are separated but need to collaborate closer to enable but also demand a successful, profession oriented vocational learning.
3. Virtualization within the education sector: In the age of web2.0 more and more often learning becomes de-formalized, i.e. independent of a formal learning programmed or a specified learning organization. Additionally one may acknowledge that we do not especially mean learning but talk about knowledge exchange within professional and private contexts.
4. Measurement of learning outcome: Momentarily online and digital media technology is used in a rather limited manner, mainly for administrative or information management purposes. True learning and teaching activity is only partly considered. Especially the opportunities to measure the learning outcome are only marginally explored, here a fast developing demand can be observed.
5. Overall configuration of learning/ educational systems: It is rather likely that a new structure of the educational system is not only needed but will arise. When we currently have a differentiation between 2 - 4 year phases before the professional career starts and in the longer run rather brief educational phases of only a few days are used to attend continuous and further training one may expect that the new way of online educational interventions at the work

place will trigger the usage of micro learning formats heavily.

### **REFERENCES**

- [1] El-Gamal, A. & Köhler, T. (2009). Fostering students learning of course management system by using blended learning; In: Bradley G. & Kommers, P.: Proceedings of the „ICT, Society and human beings 2009” and IADIS International Conference „Web Based Communities 2009”; IADIS Press.
- [2] Frindte, W., Köhler, T., Marquet, P. & Nissen, E. (2001). IN-TELE 99 - Internet- based teaching and learning 99; Frankfurt am Main, Peter Lang Verlag.
- [3] Hampel, T., Kahnwald, N., Roth, A. & Köhler, T. (2005). An adaptable platform for digital community development; In: International Reports on Socio-Informatics (IRSI). Special Issue Digital Communities, Vol. 2 Iss. 2.
- [4] Kahnwald, N., Köhler, T. (2008). Die Sifa-Langzeitstudie: Design und Umsetzung einer Online-Erhebung zur Tätigkeit von Fachkräften für Arbeitssicherheit; In: Jakob, N., Schön, H. & Zerback, T.: Sozialforschung im Internet: Methodologie und Praxis der Online-Befragung; Wiesbaden, VSS.
- [5] Köhler, T. (2006). From learning to practice. New strategies for knowledge management in the digital economy; In: Frontiers of e-Business Research, vol. 4.
- [6] Köhler, T., Mohamed, B., Bömer, C., Simmert, H. & Kersten, S. (2011). Sustainable learning on Ph.D. level. Project based online research training in the education & technology research network; In: Paulsen, M.F. & Szücs, A. (Eds.): Learning and sustainability. The new ecosystem of innovation and knowledge, Dublin: EDEN Publishers.
- [7] Lave, J., & Wenger, E. (1991). Situated Learning. Legitimate peripheral participation. Cambridge, MA: Cambridge University Press.
- [8] Mohamed, B. & Köhler, T. & (2010). The effect of project based web 2.0-learning on students’ outcomes; In: Kinshuk, Sampson D.G., Spector, M.J., Isaias, P., Ifenthaler, D. & Vaslu, R. (2010). Proceedings of the IADIS international Conference on cognition and explanatory learning in the digital age (CELDA 2010).
- [9] Mohamed, B. & Köhler, T. (in Press). The effect of project based web2.0 learning on student outcomes; In: Sampson et al.: Towards Learning and Instruction in Web 3.0. Advances in Cognitive and Educational Psychology; New York, Springer.
- [10] O’Reilly, T. (2005). What is Web 2.0?; accessed under: <http://www.oreillynet.com/pub/a/oreilly/tim/news/2005/09/30/what-is-web-20.html>.
- [11] Putnam, R. T. & Borko, H. (2000). What Do New Views of Knowledge And Thinking Have to Say About Research on Teacher Learning?; In: Educational Researcher 29(1): 4-15.
- [12] Simmert, H., Köhler, T. & Kersten, S. (2011). The use of the learning – and content management system „OPAL” as a teaching arrangement; In: Paulsen, M.F. & Szücs, A. (Eds.): Learning and sustainability. The new ecosystem of innovation and knowledge, Dublin: EDEN Publishers.
- [13] Trimpop, R., Winterfeld, U., Hamacher, W. Kalveram, A., Schmauder, M. Köhler, T. et al. (2008). Wirksamkeitsfaktoren im Arbeitsschutz: Ergebnisse der Vertiefungsstudie zu Motiven in der ersten Befragungswelle von 1000 Sicherheitsfachkräften der Sifa-Langzeitstudie; In: Schwennen, C., Elke, E., Ludborz, B., Nold, H., Rohn, S., Schreiber-Costa, S. & Zimolong, B. et al. (Hrsg.): Psychologie der Arbeitssicherheit und Gesundheit: Perspektiven und Visionen. 15. Workshop 2008. Kröning, Asanger.

# TRANSFORMING TECHNICAL AND VOCATIONAL EDUCATION AND TRAINING (TVET) BY ADDRESSING THE 21ST CENTURY ISSUES AND CHALLENGES

Dr. Paryono

SEAMEO VOCTECH Brunei Darussalam, Seconded from State University of Malang, Indonesia

paryono@voctech.org.bn

## Abstract

In response to the fast changing technologies and demands from labour market, TVET should prepare workers with multiple skills and the ability to adapt rapidly through continuous learning. Based on the identified 21<sup>st</sup> century current issues and trends in TVET, this paper offers strategies in response to the selected trends and issues identified. Some of the selected trends and issues are (1) Information and Communication Technologies (ICTs) in TVET, (2) relevancy of curriculum, (3) articulation and assessment, (4) research and development, (5) access and equality, (6) management and quality assurance, (7) poverty reduction through non-formal TVET, (8) life-long learning, (9) promoting decent work; and (10) breaking down the barriers between formal, non-formal and informal approaches (SEAMEO VOCTECH, 2008). Some of the proposed transformation strategies include the integration of 21<sup>st</sup> century skills in the curriculum that will promote lifelong learning and enhance competitiveness, the integration of ICT in TVET for improving education access and quality, and articulation arrangements to promote efficiency and effectiveness.

**Keywords** : vocational and technical education and training, trends and issues, transformation strategies, 21<sup>st</sup> century skills.

## 1. Introduction

Technical and vocational education and training (TVET) has been in the forefront of UNESCO agenda, especially on trying to achieve the objectives to (1) provide TVET for all; (2) orient TVET for sustainable development; (3) strengthen TVET as an integral component of lifelong learning (UNESCO, 2005 & UNESCO-UNEVOC, 2006). This agenda has been well received by most countries in Southeast Asia, including Indonesia, especially by expanding the access to TVET at secondary schools.

Referring to the broad definition of TVET, this type of education and training can take place either in formal schools (i.e. kindergarten through to grade 12, or in post-secondary community and/or technical colleges, or informally by means of training at the workplace and increasingly by distance media. In the case of Indonesia, TVET at elementary (1st to 6th grade) and at junior high schools (7th to 9th grade) is offered in few subjects or courses while at secondary level or senior high schools TVET is offered as a programme separate from the academic or general high schools. TVET at the postsecondary level is offered in community and technical colleges, polytechnics and diploma programmes. Short-term technical and vocational training programmes are offered by companies and

training centres under the Ministry of Manpower and Transmigration.

At the UNESCO Expert Meeting held in Bonn, Germany, 25 to 28 October 2004, it was contended that since education is considered the key to effective development strategies, technical and vocational education and training (TVET) must be the master key that can alleviate poverty, promote peace, conserve the environment, improve the quality of life for all and help achieve sustainable development. With this, TVET has to re-orient its agenda for action so as to continually provide scientific and technical skills in relevant and responsive programmes, and consequentially develop a new generation of human resources.

In this 21st century, TVET has to address various issues and challenges especially in response to changing technologies and demands from the labour market. TVET should be able to prepare workers with multiple skills and the ability to adapt rapidly through continuous learning. TVET should correspond to the country's economy and employment so that the programmes can produce relevant graduates.

The other issue that TVET should address is preparing its students for getting jobs, providing career options and progression, and at the same time also providing opportunity for further education. To take this role, TVET should offer

programmes that are not too narrow, providing strong basic academics and technical skills.

Based on the current trends and issues identified by SEAMEO VOCTECH, a Regional Centre in Vocational, Technical Education and Training under the Southeast Asian Ministers of Education Organisation, Colombo Plan Staff College (CPSC), and UNESCO-UNEVOC, this paper offers salient recommendations that can provide input for improving TVET in the 21st century. The following sections will discuss those current trends and issues followed by initiatives in response to the selected trends and issues.

## 2. Current Trends and Issues in TVET

The following TVET trends and issues in Southeast Asia and beyond were based on various studies by SEAMEO VOCTECH, Colombo Plan Staff College (CPSC), and UNESCO-UNEVOC in 2007-2008 (SEAMEO VOCTECH, 2008) and have been updated based on Khambayat and Majumdar (2010). The most salient trends and issues in TVET are as follows:

1. ICT in TVET
2. Relevancy of Curriculum:
  - School- business and industry partnerships
  - Integration of “common skills” or “soft skills” or “employability skills”
  - Integrating entrepreneurship education in the curriculum
  - Curriculum for sustainable development.
3. Articulation and Assessment
  - Horizontal and vertical articulations
  - What and how to assess students
  - Transferability and recognition of the certificates (within the country and region)
  - Labour mobility.
4. Research and Development
  - Proliferation of research-based policies and practices
  - Knowledge-based economy and society.
  - Research networking and partnerships.
5. Access and Equality
  - Expansion of student enrolment
  - Inclusion of minorities and disadvantaged groups, reaching the unreached
6. Management and Quality Assurance
  - Improvement of overall quality
  - Image improvement of TVET
7. Poverty reduction through Non-Formal TVET
8. Life-long learning
9. Promoting decent work; and
10. Breaking down the barriers between formal, non-formal and informal approaches.

## 3. ICT in Education

Information and Communication Technology has been a major thrust that shapes the way TVET institutions deliver the education and training to students. In some SEAMEO-member countries, ICT was not fully integrated in their education but all see the importance of it and progressively improve the way they use the existing technology according to their capacity (Paryono & Quito, 2010).

Respondents observed that there has been an increase in the use of ICT in teaching and learning through web-based application and integration in some subjects. There is also an increase in training or staff development through ICT, e-learning, and using teleconferencing.

## 4. Relevancy of Curriculum

TVET institutions should be able to keep up and respond to the fast changing needs of the labour market. Partnering with relevant business and industry is one of the issues raised by respondents so that the TVET institutions can offer the most updated programmes. The issue of “common skills” or what are sometimes called “soft skills” or “employability skills”, which are personal attributes that enhance an individual's interactions, job performance and career prospects, should be integrated in the curriculum. Some of the examples of these skills are optimism, common sense, responsibility, a sense of humor, integrity, and abilities that can be practiced such as empathy, teamwork, leadership, communication, good manners, negotiation, sociability, and the ability to teach (Parsons, 2008).

The 21st century skills comprised of soft skills, basic math and science, and ICT skills are considered very crucial in today's working environment. Countries like Brunei Darussalam, Indonesia, Malaysia, Singapore, and the Philippines have been proactive in integrating soft skills in the curriculum. But the implementation varies from country to country.

Entrepreneurship education was also considered an important component that should be integrated in the curriculum which leads to provide self-employment opportunity and creating jobs for others. This is very important interventions for poverty reduction. In the future, TVET should provide business incubator to support the new and existing enterprises.

Curriculum for sustainable development is perceived as an important component that should be addressed in TVET. Considering that much can be done through TVET to sustain the environment, TVET institutions should be able to take active roles in this effort.

## 5. Articulation and Assessment

Articulations can be done horizontally and/or vertically. Horizontal articulation is done at the same level of education by recognizing or matriculating credits of courses from one school to the other, e.g. matriculating courses from secondary TVET institutions to secondary academic schools or vice versa, from postsecondary TVET institutions to postsecondary academic institutions or vice versa.

Vertical articulation is done between lower level TVET institutions to a higher level. This type of articulation is occurring in several countries in the region. To encourage students to enrol in TVET and to avoid repetition of courses, the approved courses and credits from the lower level of education can be transferred to next education level according to matriculation mechanisms.

The TechPrep initiative in Malaysia, which was originally from the U.S., recognizes some of the courses taken in secondary level to be matriculated at the higher level. The 2+2+2 programme offers students advantages because the TVET courses taken during the last two years in high school plus 2 years of participation in postsecondary vocational and institution will qualify the students to receive a diploma certificate, and if they continue for two more years of education in the university level they will qualify for an undergraduate degree.

Brunei Darussalam is introducing changes in the TVET framework which includes the introduction of a 3-Tier TVE: National Skill Certificate, Diploma and Technical Degree. Thailand is also introducing similar arrangements.

Assessment and certification are other issues that all member countries share similar concerns about. They are not only focusing on how to assess students but also the possibility of expanding the transferability and recognition of the certificates. The idea of Regional Skills Recognition are being studied and discussed by multi-lateral agencies including ILO, ASEAN, and SEAMEO VOTTECH. The initiatives to pilot some areas of employment, such as in Hospitality and Tourism in limited number of countries, have been undertaken but it is still a long way to go to fully implement the Skills Recognition Arrangement at the regional

level.

## 6. Research and Development

In the information era, the SEAMEO member countries are moving at different speeds towards knowledge societies where educational policies and practices will be supported by data, facts, and/or research findings. The awareness of having research-based policies and practices is very strong but obstacles are still ahead especially on enhancing the staff's capability in the conduct, manage, and use research activities.

Research activities are still fragmented and isolated. Networking and partnerships to conduct research and to share the findings should be strengthened not only among the institutions within the country but within the region as well.

## 7. Access and Equality

Increasing enrolment in TVET through easing access and encouraging minority participation in TVET is the trend in the region. Brunei Darussalam, for example, through Sistem Pendidikan Negara (SPN) 21, puts more emphasis on TVET. The enrolment in Institute of Technical Education (ITE) in Singapore is also increasing and image of TVET has improved dramatically. In Malaysia, Thailand, and the Philippines TVET is also gaining momentum that more youths are more interested in enrolling in this type of education. Indonesia is even more ambitious; the Directorate of Management for Secondary Technical and Vocational Education of Indonesia is planning to increase enrolment ratio between general schools to vocational schools students to 30:70 by 2015 that was revised recently to 33:67. To follow up the initiative, the government is continuously supporting facilities and promoting this programme to communities. Some practical programmes managed by the DSTVE includes building and workshop renovation, developing new vocational schools facilities in the remote area, offering scholarships based on merit, and scholarships based on poor & disadvantages people (DTVE, 2006). This proportion is very high compared to other countries in the world, except Belgium and Austria, see Table 1.



Table 1. *Shares of General and Vocational Programmes in Senior/upper Secondary Education*

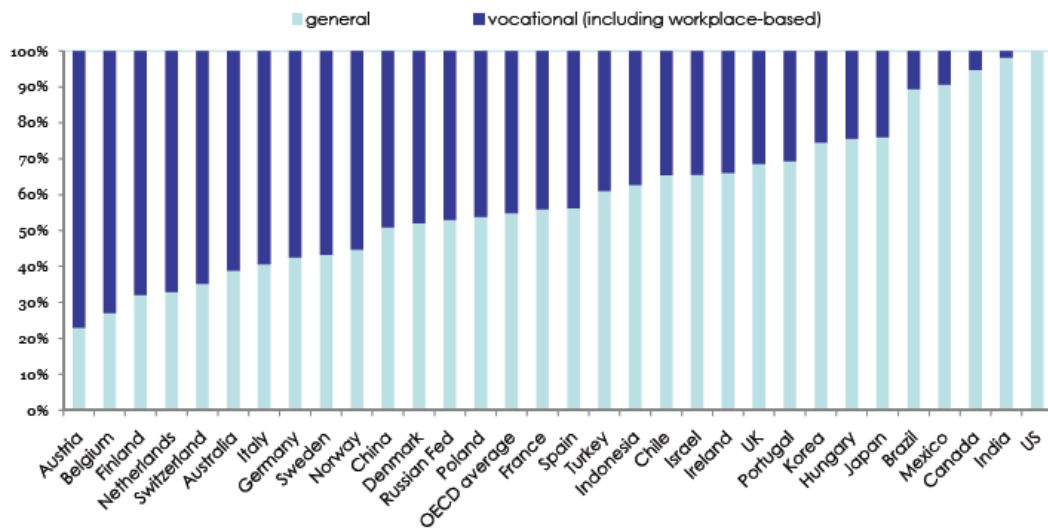

Source: Roseveare (2010)

## 8. Management and Quality Assurance

The increasing complexity of the educational system including TVET system requires better management both at national and provincial levels. Consequently, capacity building for administrators is needed.

In the same line, mushrooming TVET institutions worries both educational practitioners and policymakers especially in regards to the quality of education and training programmes they offer. Quality assurance, therefore, is an important issue that should be addressed holistically. This quality assurance is also directly related to the issue of matriculation and accreditations that eventually affect the skills recognition of the graduates. Thus, the issue of workers mobility should be addressed by initiating the discussion on quality assurance.

## 9. Poverty reduction through Non-Formal TVET

Non-formal TVET such as the one offered by Ministry of Manpower and Transmigration of Indonesia and those organized by community and industries can play very important roles in helping those who cannot afford to enroll in formal TVET. Training for unemployed individuals with job-specific training will enhance their employability and eventually can pull them out of poverty. This type of training is usually short term, few days or weeks and less structured.

## 10. Life-long learning

In this era, where technology changes so rapidly, knowledge-based sectors are dominating industry's revenues thus every country is required

to produce more knowledge workers. Education, including TVET, should offer more flexibility to students and provide a strong foundation on learning how to learn. The easy access to information through various media and the possibilities of carrying out jobs through various ways has open opportunity to individuals to learn continuously throughout their lives regardless of their age.

Lifelong learning is one of the important components of 21st century workforce requirements, besides among others adaptability, practical skills, awareness of global issues, communication skills, and teamwork. As summarized by Khamayat and Majumdar (2010), "Twenty-first century skills combining technology literacy, critical thinking, creativity and mastery of core subject matter are the lifeblood of a productive workforce in today's global, knowledge-based economy."

## 11. Promoting decent work

As initiated by International Labour Organisation (ILO), TVET should promote decent work. TVET as producer of future workforces should devote to advancing opportunities for women and men to obtain decent and productive work in conditions of freedom, equity, security and human dignity. Further ILO stated that TVET should promote rights at work, encourage decent employment opportunities, enhance social protection and strengthen dialogue in handling work-related issues (ILO, 2011).

## 12. Breaking down the barriers between formal, non-formal and informal approaches

This trend is in line with lifelong learning and education articulation whereby learners can have the opportunity and options to enroll in various learning avenues throughout their lives and their learning experiences can be recognized no matter where they learned it from (UNESCO-UNEVOC, 2008). In Indonesia, the policy of multi-exit and multi-entry is in line with this trend.

## 13. Initiatives in response to current trends and issues

In response to the above trends and issues in TVET, this paper proposes some initiatives that can be grouped into the followings:

## 14. Integration of 21<sup>st</sup> century skills

This initiative is particularly in response to the trends and issues on ICT in TVET and relevancy of curriculum. This is also to promote lifelong learning and enhance competitiveness of TVET graduates.

In this 21<sup>st</sup> century, expertise is a process, not a level of aptitude and TVET must incorporate meta-cognitive skills, which is part of the 21<sup>st</sup> century skills, “to allow self directed learners to continually improve, to allow coaches and mentors to better guide development, and to recognize a wide array of “spaces” in which learning might take place” (Todd, 2010). There is also an increasing recognition that technical expertise alone is insufficient to ensure employability –“know how” must be accompanied by “know who” and “know

what” – contextually embedded practices and networks, professional expectations, ethics, values and norms (Inkson & Arthur, 2001).

The importance of 21<sup>st</sup> century skills, within which also include “good work cultures” is also stressed by prominent economist David Landes stating that these skills can be the determining factors for country’s development.

“Although climate, natural resources, and geography all play roles in explaining why some countries are able to make the leap to industrialization and others are not, the key factors is actually a country’s cultural endowments, particularly the degree to which it has internalized the values of hard work, thrift, honesty, patience, and tenacity, as well as the degree to which it is open to change.” David Landes, *The Wealth and Poverty of Nations* as cited by Friedman (2005).

The integration of 21<sup>st</sup> century skills in TVET curriculum has led to demands for broader forms of initial vocational education which lay the foundation for further learning. These essentials and foundations skills are very crucial for the 21<sup>st</sup> century. The response to this in many countries has been to readjust upper secondary vocational programmes to contain a larger element of general education and more generic forms of vocational preparation, where the latter prepares participants for a cluster of occupations in a given sector rather than for a single one (Atchoarena, 2010).

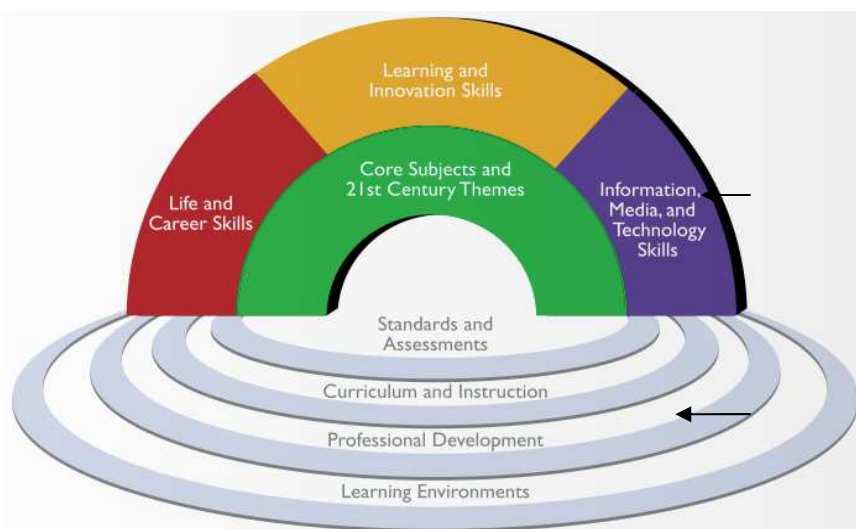

Figure 1. 21<sup>st</sup> Century student outcomes and support systems



The broad thinking around 21st century learning acknowledges the need for new “form and function” to be added to education goals. This thinking is informed by a belief that learning must leverage the affordances of new technologies, employ better pedagogies based on recent research on how people learn, and be cognizant of the characteristics of a new breed of learners. This is not say that “basics” and “core subject learning” need to be done away with (Smartbean, 2009).

To summarize, the 21st century skills can be stated as the following, “To be productive contributors to society in our 21st century, you need to be able to quickly learn the core content of a field of knowledge while also mastering a broad portfolio of essentials learning, innovation, technology, and careers skills needed for work and life” (Trilling & Fadel, 2009, p16).

#### **15. Enhancing TVET efficiency and effectiveness**

To enhance the efficiency and effectiveness of TVET, there are few suggestions to be considered: horizontal and vertical articulations, breaking down the barriers between formal, non-formal and informal approaches, and enhancing school-business and industry partnerships. Increased possibilities for transfer between vocational and academic courses have been initiated in Indonesia, including improved progression routes into, and out of, the vocational tracks. In practice, however, there are many obstacles in the fields. For vertical articulation, a further development has been to devise progression routes for the vocational tracks so that successful students may have further access to tertiary level education and some courses taken at secondary level can be matriculated for tertiary level courses.

The implementation of National Qualification Framework (NQF) that recognizes all forms of learning at various levels will minimize the barriers between formal, non-formal and informal learning and promote lifelong learning. NQF incorporates the qualifications from each education and training sector into a single comprehensive national qualifications framework which is very useful for recognizing various types of learning.

To improve the relevancy of TVET programmes, partnerships between school and industry is necessary. School and industry can share resources that will benefit both parties. The strong partnership with industry can also improve job information and career guidance for the students.

To address the issue of access and equality, TVET should open to all by including minorities,

disadvantaged groups, and reaching the unreached regardless of gender, ethnic, and religious background by using the ICTs and other approaches,. This expansion, however, should correspond to the needs of labour market and national economy. The government has a role to provide education, especially TVET for all, providing career guidance to the students, and in the end let them decide what type of education they want to pursue.

#### **16. Continuous Improvement through Research and Development**

The initiation of research division at the school level or district level is necessary at least to tackle institutional research in this knowledge-based economy. Secondary and postsecondary educational institutions should work hand in hand to conduct research to proliferate research-based policies and practices.

Some of the research agenda that can be tackled are TVET management and quality assurance that eventually can improve of overall TVET quality and the image of TVET. By utilizing the data from school, alumni, and industries, a school management should encourage their staff to conduct

institutional research. This type of research can among others continuously update school statistics, tracer study, and labour market prediction.

To improve teaching-learning process, teachers should be equipped with skills in conducting classroom action research. This will provide opportunity for teachers to share their experiences with others in conferences or through publication of their findings that eventually will inspire them to improve their teaching, improve their creativity and innovativeness.

#### **17. Concluding remarks**

TVET does not exist in a vacuum; it is shaped and should correspond to the changing demand of labour market, economy, and socio-cultural phenomena that is affected by globalization. TVET roles in the 21st century are paramount, providing opportunities for individuals for better careers and lives, helping industries improve their

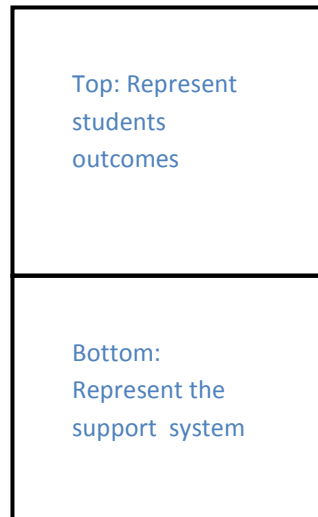

performances, and improve quality of national workforces that will help country's prosperity.

In the past, material forces were dominant in national growth, prestige, and power; now products of the mind take precedence. Previously, developed countries were thinking hard about how to continuously improve the quality of products while the developing countries were focusing on producing cheaper products. In this era, where knowledge economy is getting more dominant, the dichotomy between "head" or thinking countries and "body" or manufacturing countries including the types of work that TVET graduates perform is getting blur. The results of this blurring dichotomy are new and productive partnerships between developed or nations, which design products, and the developing nations (Brown & Lauder, 2010). TVET, therefore, can be the mediator between developed and developing nations by exchanging their workforces and expertise to complement each other.

In this 21st century where technological changes are fast moving and labour mobility is continuously increasing, TVET should be able to address the current trends and issues. From the ten selected trends and issues identified by SEAMEO VOCTECH, CPSC, and UNESCO-UNEVOC, this paper offers some initiatives in response; among others are the needs to integrate 21st century skills in the curriculum. To integrate these skills, TVET institutions should integrate academic learning with technical learning across the curriculum, maintain high academic standards for all students, and focus on careers in growing or emerging industries.

To address TVET efficiency and effectiveness, we can introduce articulation, both horizontal and vertical, initiate National Qualification Framework, enhance partnership with industry, and reaching the unreached especially by using ICTs. Allowing students to earn college credit for college-level courses taken in high school can promote TVET and attract students.

Continuous improvement of TVET through research and sharing should be encouraged, starting from institutional research, classroom action research, and can be expanded to applied research. This 21st century is an era full of challenges; innovations are happening all the times and in large scale; the world becomes "smaller" and "flatter" in the sense that people can access to information easier and can participate in collaborative works across nations regardless of their differences. To face this era, TVET practitioners should think and practice differently to prepare graduates with competencies, not only relevant skills but also general knowledge that can be applied in the fast changing working environment.

## References:

- [1] Atchoarena, D. (UNESCO). (2010). *Strategies for school-to-work transition*. A paper presented at HR Forum, Seoul, Korea. 26-28 October 2010.
- [2] Brown, P. & Lauder, H. (2010). *Globalization, Corporate Strategies and the Future of Work*. A paper presented at HR Forum, Seoul, Korea. 26-28 October 2010.
- [3] Directorate of Management for Secondary Technical and Vocational Education (PSMK). (2006). *Education Strategic Plan*. Jakarta: Department of National Education
- [4] Friedman, T.L. (2005). *The world is flat: A brief history of the twenty- first century*. New York: Farrar,. Straus and Giroux.
- [5] ILO(2011). *Decent work agenda*. Retrieved on July 3, 2011, from <http://www.ilo.org/global/about-the-ilo/decent-work-agenda/lang--en/index.htm>
- [6] Inkson, K. & Arthur, M. (2001). How to Be a Successful Career Capitalist. *Organizational Dynamics* 30(1): 48-61.
- [7] Khambayat, R.P. & Majumdar, S. (2010). Preparing teachers of today for the learners of tomorrow. *Journal of Engineering, Science and Management Education*, 2, 9-16.
- [8] Landes, David S. 1998. *The Wealth and Poverty of Nations: Why Some Are So Rich and Some So Poor*. New York: W.W. Norton
- [9] Majumdar, S. (2010). *TVET Response to global trends in Colombo Plan region*. Manila: CPSC.
- [10] National Quality Council TVET Australia. (2010). *Foundation skills in VET products for the 21<sup>st</sup> century*.
- [11] Parson, T.L. (2008). *Definition: Soft Skills*. Retrieved on July 1, 2011 from <http://searchcio.techtarget.com/definition/soft-skills>
- [12] Paryono & Benjamin, Q. (2010). *Meta-analysis of ICT Integration in Vocational and Technical Education in Southeast Asia*. A paper presented at International Conference on VTET Research and Networking 2010, SEAMEO VOCTECH, Brunei Darussalam on 23-24 June 2010.
- [13] Roseveare, D. (2010). *VTET for skills and green growth: OECD perspectives paper presented and Global*. A paper presented at HR Forum, Seoul, Korea. 26-28 October 2010.

- [14] Route 21. *Building 21<sup>st</sup> century Skills*. Retrieved on June 1, 2011, from [http://www.p21.org/route21/index.php?option=com\\_content&view=article&id=5&Itemid=2](http://www.p21.org/route21/index.php?option=com_content&view=article&id=5&Itemid=2)
- [15] Omar, S. & Paryono. (2008). Current trends and issues in VTET: SEAMEO VOCTECH's response. *SEAMEO VOCTECH Journal*, pp: 38-49.
- [16] Smartbean (2009). *What are 21<sup>st</sup> century skills?* Retrieved on July 3, 2011, from <http://www.thesmartbean.com/magazine/21st-century-skills-magazine/what-are-21st-century-skills/>
- [17] Treet, T. (2010). *Process, proximity, and collaboration: Industry ties to vocational education and workforce development*. Conference proceedings from International Seminar on Vocational Education and Training, 18 May 2010. Yogyakarta: Graduate School Yogyakarta State University.
- [18] Trilling, B., Fadel, C. (2009). *21st century skills: learning for life in our times*. San Francisco, CA: Jossey-Bass. <http://www.21stcenturyskillsbook.com/index.php>
- [19] UNESCO (2005). *TVET for All: Advocacy*. Retrieved on July 3<sup>rd</sup>, 2011 from [http://portal.unesco.org/education/en/ev.php-URL\\_ID=32676&URL\\_DO=DO\\_TOPIC&URL\\_SECTION=201.html](http://portal.unesco.org/education/en/ev.php-URL_ID=32676&URL_DO=DO_TOPIC&URL_SECTION=201.html)
- [20] UNESCO-UNEVOC. (2006). *Orienting Technical and Vocational Education and Training for Sustainable Development*. A discussion paper Series 1. UNESCO-UNEVOC International Centre for Technical and Vocational Education and Training, Bonn, Germany.
- [21] UNESCO-UNEVOC (2008). *Final Report UNESCO-UNEVOC International Experts Seminar*. Dublin Institute of Technology, 15 December 2008.

# INCORPORATING CHARACTER BUILDING AND DEVELOPMENT OF ENGLISH PROFICIENCY FOR VOCATIONAL SCHOOL STUDENTS GRADE X MAJORING AT OFFICIAL ADMINISTRATION

Agustina Ari Wisudawati

Yogyakarta State University  
ag\_ariwisudawati88@yahoo.com

## Abstract

Being able to communicate in English as well as possessing the good working ethos is part among many criteria which the labor force graduated from Vocational School majoring at official administration grade X need to attend. English proficiency level is necessary to be developed among them since it serves as the medium of communication in their future working field. In addition, character building offers the base of the working ethos among the professional labor force. Unfortunately, there were still a lot of Vocational School's students grade X, majoring at official administration are difficult to achieve sufficient English language aptitude. Moreover, English teaching was separated to the character building among the students. Teaching English became the discrete learning aimed only to facilitate the students to be exposed to the cognitive aspect of learning. Therefore, this paper addressed two questions (1) how to develop an English learning material which was integrated with character building for Vocational School students majoring at official administration? (2) How is the presentation of English learning material which is integrated with character building for Vocational School's students majoring at official administration? In developing the English learning material integrated with character building some steps to do are (a) conducting need analysis (b) stating the learning objectives (c) deciding the subject content and (d) considering the learning activities. The presentation of English learning material integrated with characters building are (a) getting ready, moving forward (b) act it out (c) checking your competence (d) and making reflection

**Keywords:** character building, English proficiency, vocational school, official administration.

---

## 1. Introduction

Vocational School must do better job at educating the future workforce. One of the problems is student's preparation for the workplace (Buchman and Huisinga, 2008; Shulz and Charles, 2011; Mifa, 1994). One aspect which needs to be prepared in encountering the job is building the character (Benawa, 2008). Besides, developing the English language proficiency is also needed (Hutchinson, 1987). This study will discuss about incorporating the character building and the development of language proficiency for the students of Vocational High School majoring at official administration of SMKN 1 Godean Sleman (*Sekolah Menengah Kejuruan / Public Vocational School*) I Godean Sleman.

The students of Vocational School need to develop the good character before entering the working field due to some reasons. First, official administration students will possess the huge extended impact in their future working field and responsibility (Suseno, 2008; Hardiman, 2008). That means that what he or she does will influence others. Besides, what they do require the important responsibilities (Marianti, 2007).

Besides building the character, English is chosen as the main concern of this study due to the fact that they need English in the future working field (Hutchinson, 1987). In fact, the English mastery of the students majoring at official administration SMK I Godean Sleman still needs to be developed. Students need to be encouraged to communicate spontaneously. Moreover, The English teaching learning seems to be discrete for the students majoring at official administration of SMKN 1 Godean Sleman. English is not yet incorporated with the character building. On the other hand, character building and language learning needs to be integrated. Considering to the current phenomenon, the writer intends to develop the English Learning for the students majoring at official administration Grade X SMKN I Godean Sleman. There are two main questions which this study addresses namely (1) How to develop an English learning material which is integrated with character building for students of SMKN 1 Godean majoring at official administration? (2) How is the presentation of English learning material which is integrated with character building for SMKN 1 Godean Sleman majoring at official administration?

## **2. Theoretical Review**

### **2.1 Figures and Tables**

In order to develop an instructional design for the students, the writer follows the steps proposed by Kemp (1997). There are some steps to follow. The steps are (1) deciding the goal, topic and general purposes; instructional design model can be started with deciding the broad goal. The broad goal is from on school system and institution goal which derived from society, students and subject areas (2) Considering learners' characteristic; learner's characteristic should be taken into account such as academic and non academic factors; maturity, attention span, special talents, physical and emotional handicaps, and socioeconomic situation, what the learner's want (3) stating learning objectives. Learning objective is the teaching-learning outcome which can be measured. Learning objective serves as a means to evaluate the students learning and effectiveness of an instructional design. (4) Deciding subject content; subject content should be in line with learning objectives. It is arranged in logical organization, from the simplest into the most complex one.

### **2.2 English for Specific Purpose**

According to the theory of ESP (English for Specific Purpose), one of the approach to course material design, there are at least three factors to consider for an instructional design. Those factors are necessities, lacks and wants (Waters and Hutchinson, 1987; Macalister, 2010)

Necessities defined as the demand of the target situation. In other words, necessities are what the learners have to know in order to function effectively in the target situation. For example a teacher should be able to know how to conduct teaching learning classroom interaction in English or a businessman has to know the business letter in English and so on. Lack refers to the discrepancy between what the target situation demand and what learners have already known in order to fulfill the demand of target situation. A designer should be able to identify the lacks to bridge the discrepancy between the target situation and the learner's ability. Identifying what the learner's wants is the main concerns of ESP. Learners wants play an important role to encourage learner's motivation. Not taking into account learners' wants means ignoring their motivation which contribute to their learning succeed.

### **2.3 Teaching Language**

The recent view argues that teaching language is an integrated teaching. There are some skills which language teaching deal with namely

speaking, listening, reading and writing. In speaking there are some obstacles which the students may encounter. They often had no idea to speak, were lack of vocabulary and were reluctant to speak. Therefore, relating speaking with the students' background knowledge and give them the ideas to speak by providing them with the video and reading passage can be employed as an alternative for speaking activity. In addition, a teacher can employ the used of the group work and interactive activities. The second one is dealing with listening and reading. There are two common principles for teaching listening and reading. The first one is bottom up process the second one is the top down process. In bottom up process, the students were given some vocabularies or utterances which will appear in the passage. The top down processes utilize the use of the students' background knowledge in order to understand the passage. The writing process consists of some steps namely brainstorming, drafting the idea, developing the paragraph and revising (Richard and Renandya, 2010).

### **2.4 Character Building**

Character building of the working force became the main issue in these recent days due to the fact that the character which the worker possessed will determine the success or failure of the team (Latief, 2007; Lie, 2007). According to Koesoema (2007a) and (2007b), there are some ways to teach the character building. The first way is through presenting or to make salient of what character is to be understood by the students. In this case, the character building requires the students to have the awareness on what they have done or whether what they do is in line with particular values. The second ways is doing an action. After the character which they need to possess and why they need to possess particular character is developed, implementing the character is the next step for the students. Implementing the values that the students have acquired can be done through many tasks which are incorporated with the teaching learning process. Therefore, instead of only accomplishing the particular tasks, the students need to be able to implement the values which they have learned. Since the nature of the character building is creating the students' awareness, therefore, reflecting on how far they have been able to live the value they learn should be conducted. Through having the reflection, the students are able to see in themselves. Thus, they can assess themselves in order to seek for improvement (Benawa, 2008; Koesoema, 2007).

There are also values which workforce needs to develop such as cooperating, serving the customers well, building the good communication,

politeness, communicating in a good body language, grooming, interpersonal relationship, team work, personality, etiquette, responsibility, professionalism, building professionalism (*Silabus Administrasi Perkantoran*, 2011).

### 3. Discussion

#### 3.1 Steps of Developing Material for the Official Administration Students

There are some steps which are employed to develop the learning material which manage to incorporate the English Language proficiency development and the character building.

##### 3.1.1 Conducting Need Analysis

As it is proposed by Kemp (1997), in order to produce the good instructional design, the deciding the goal is the first step to do. In order to accomplish the data, the writer conducted the need analysis to the students grade X SMKN 1 Godean Sleman majoring at official administration. According to the data that the writer assembled, it was found that 100% of the students grade X SMKN 1 Godean Sleman majoring at official administration taken as the sample admitted that they learned English on order to function the language in the future work. All of them needed English in order to communicate with the colleague, and to communicate with boss and customer. Therefore, 80% of them agreed that they needed to acquire active English in order to function well in their future job. It was found that 100% percent of the students mentioned that their future job concerned with handling the administrative things. However, 80% of them admitted that they can handle administrative things both in the *Bahasa Indonesia* and in English. In fact, 75% of the students noticed that they were able to function English communicatively in written form though they were not fluent.

Besides learning need, another factor to consider was lack (Kemp, 1997; Hutchinson and Waters, 1987; Macalister, 2010) In order to obtain the data about the students' lack the writer employed the use of interview, questionnaire and test. Instrument employed in obtaining the data about the students' current level proficiency was the test. The test was aimed to understand the students' current level of proficiency as it was suggested by Kemp (1997), Hutchinson (1987) and Macalister (2010). In the test, it was shown that the students were sufficient at written communication but not at the oral communication. Nonetheless, their written proficiency was still need to be optimized. In order to obtain the learners' lack, the data obtained from the test was supported by the questionnaire and the interview result. The questionnaire result showed that 85% of the

students still found the difficulties for communicating spontaneously in English both in oral in written form. Vocabularies and grammar occupied the 80% of the problems in all of the four skills (listening, speaking, reading and writing). Besides the vocabulary, 80% of the students acknowledged that in the oral communication both in speaking and listening, they were difficult to communicate in English because of the pronunciation problems. Some of them were still difficult in fine-tuning the English utterances for them to understand and in pronouncing some utterances in English. Besides pronunciation, the main problem of the students is related to the speaking fluency. All of the students agreed that fluency remain the serious problem in speaking English spontaneously.

In the questionnaire given to the students, they admitted that they found some psychological handicaps while learning English. The majority of the students, 70% of them felt shy, and nervous while learning English. The other thought that they were reluctant while trying to speak in English. They were afraid of making mistake while trying to produce the language.

Another instrument employed for digging out the information about the learners' lack was the interview. While conducting the interview with the students, they were asked the reason why it was difficult for them to communicate in English. They admitted they often found difficulties when being asked to respond the statement as quick as possible. Moreover, the students also tended to translate what their idea in the first language before they said something in the second language. Rather than trying to deliver the idea, translation often made them difficult to utter statements in English. In the interview, 70% of the students said that they were sometimes frustrated to learn English. 85% of the students admitted that though it they had learned English for many years; it was difficult for them to communicate in English spontaneously. It was obtained that 85% of the students said that they were afraid of making mistake while learning English in front of the audience. Therefore, rather than being embarrassed, it would be better for them not to speak anything. Those students also admitted that they often had no idea of what to say so that they kept silent while learning English

Another thing to consider was what the students want (Hutchinson, 1987 and Kemp, 1997; Macalister, 2010). Considering what the students' want is important as this greatly contribute to the students' motivation while learning English. From the questionnaire result, the students admit that they wanted to be able to communicate in English well both in oral and written form at least in the novice level.

Moreover, they also needed to learn in the group work. Learning in group, the admitted that they would find the more secure environment to speak in English (Krashen, 1998). Some of the group work might be various for them such as conducting simple conversation, developing role play, doing jigsaw, and so on. Besides, the learning activities can employ the problem solving and exchanging ideas.

Besides the language aspect, there are some traits which the students of Official administration need to acquire which is related to the character building. Those elements are cooperating, serving the customers well, building the good communication, politeness, communicating in a good body language, grooming, interpersonal relationship, team work, personality, etiquette, responsibility, professionalism, building professionalism.

Considering the students need, lack and want both in the language aspect and in the character building, the goal which the learning material attempted to address was to design the learning material that incorporate the four skills and character's building. Therefore, the goal was that the students were able to communicate in the oral and written form in the novice level as well as possessing the good characters needed in the working field. Thus, there were four skills integrated namely reading, writing, listening and speaking. Reading and writing was presented first in order to give the students what traits they needed to possess. That was done because teaching character was best done by giving presentation followed by implementation (Latief, 2007; Koesoema (2007a) and (2007b) ; Marianti, 2007) After reading and writing, they were asked to implement what they had learned concerning on the traits they needed to have.

### 3.1.2 Stating the Objectives

After doing the need analysis, the next step was stating the learning objectives (Hutchinson and Waters, 1987; Macalister, 2010; Kemp, 1997) . The learning objectives have been stated in the curriculum provided by the students of SMKN 1 Godean majoring at official administration. The competence standard of vocational school students in term of English proficiency was being able to communicate with people in the novice level. As it had been stated before, the syllabus had not yet clear and specific reflecting the students' need, lack and want. Therefore, considering the learners need (being able to communicate with the people fluently both in oral or written form), lack (the learners encounter difficulties in some of the language aspects such as vocabulary, grammar, speaking fluency) and want (the students' willingness to study in group), and the demand of

character which the students SMKN 1 Godean majoring at official administration such as it needed to be modified based on it necessity. Before being modified, the syllabus components consisted of (1) standard competence (2) indicator (3) learning material (4) assessment and (5) learning resources. Thus, in order to incorporate it with the character building , the students need, lack and want the syllabus needs to be added with some other elements namely (1) competence standard (2) standard competence (3) character which can be used as the learning topic(4) language function (5) learning material for each skills (6) vocabulary (7) teaching learning activity which enhance the students' level of fluency (8) learning assessment (9) time allotment and (10) learning resources.

### 3.1.3 Deciding the Subject Content

There was some competencies standard which led the syllabus to cover the subject content. However, the subject content only covered about language skills, which consists of some language function. That was good but it was no longer sufficient related with the current issue. Besides the functional language, the subject content of all skill needed to be integrated with the characters that the students of SMKN 1 Godean Sleman majoring at official administration needed to possess. Functional language will approximately similar in any situation. Nonetheless, there were some specific traits such as cooperating, serving the customers well, building the good communication, politeness, communicating in a good body language, grooming, interpersonal relationship, team work, personality, etiquette, responsibility, professionalism, building professionalism. Those traits can be employed as the topic especially the topics for reading and writing.

If those items were utilized as the topic in the syllabus, the teaching learning activity could be started with the reading and writing first and then continued by the listening and speaking process. There were some reasons why reading and writing needed to be stated before the listening and speaking. According to the theory of language learning, starting the teaching learning activity with the reading and writing passage can serve as the brainstorming ideas for the learners to produce the language especially in speaking (Richard and Renandya, 2000). The decision was made in response in response of the students' lack of idea of what to communicate. Second, the reading activity and writing greatly contributed to the students' ability in developing their vocabulary. Third, the reading passage and the writing gave the students horizon and understanding concerning some characters such as cooperating, serving the customers well, building the good communication, politeness, communicating in a good body

language, grooming, interpersonal relationship, team work, personality, etiquette, responsibility, professionalism, building professionalism (*Silabus Administrasi Perkantoran*, 2011). In line with integrating character building in the teaching learning process as it was proposed by (Latief, 2007; Koesoema (2007a) and (2007b) ; Marianti, 2007), the students were able to learn the character if they were given an understanding of what character they needed to possess and what values laid within.

#### **3.1.4 Considering Learning Activities**

Learning activities should be designed in order to encourage the students in developing their speaking fluency. The needs analysis result showed that the students were still lack of fluency which was caused by lacking of vocabularies, grammar, lack of ability to express ideas in particular language. Besides, they also faced psychological handicap while learning English such as being shy, reluctant and being afraid of making the mistakes. Therefore, the suitable way to overcome this problem is by engaging the students in the communicative activities (Richard and Renandya, 2010) Therefore, the group learning was preferred. Moreover, the group learning was assumed to facilitate the students to develop their character and giving feedback one another.

### **3.2 The Presentation of the Learning Material**

There were some elements comprising the presentation of learning material for students of SMKN 1 Godean Grade X majoring at official administration. The presentation of the learning material was developed by following the steps proposed by (Latief, 2007; Koesoema (2007a) and (2007b) ; Marianti, 2007) which concerned about character building and steps given by Renandya and Richard (2010).

#### **3.2.1 Getting Ready**

The first part was getting ready. Getting ready gave the students the idea of what they were going to learn. It served for activating the students' background knowledge before they learn further learning material. In this part, the students were asked by some questions for them to answer (the questions should be simple aimed for building the students' background knowledge only). Those questions managed to raise the students' background knowledge and the learning material which they were going to face. In this part the students were also given the opportunity to practice the pronunciation and the acknowledging some of the vocabularies which they were able to employ for communicating in the next step of learning. It was stated in the need analysis result that the students found difficulties in vocabulary and

pronunciation. Vocabulary and pronunciation practice were given so as to bridge their difficulties in those two language aspect.

#### **3.2.2 Moving Forward**

This step was intended to facilitate the students in using the language for communication. As this learning material was the integration between the character and language proficiency building, this part will be started with the reading and writing first. As the principle proposed by Koesoema (2007a) and (2007b) The reading contained some passages which gave the students horizon on the character which they needed to possess. After that, the students were given the chance to practice what they had learned in the productive skills namely writing and speaking act. What happened was in line with the principle of character building. As the students were exposed to understand what character they need to understand, they were asked to implement it. While practicing the productive skills, writing and speaking the students needed to implement some traits which they had learned. It had been stated in the need analysis that the students' face the challenges in communicating, especially in the oral communication. Therefore, reading and writing served as the aid for giving the idea for the students to produce language.

#### **3.2.3 Act It Out**

Similar as the previous step, this step was also aimed at developing the students' proficiency and character building. However, in this part, the students' were asked to understand and produce the language without any guidance given to them. In this part, the students were facilitated to implement the character and the task aimed to develop the language proficiency. There were also some activities implemented to build the students fluency and such as conversation, group work, ideas exchange and problem solving. Those group work activity was intended for developing the students' character.

#### **3.2.4 Check Your Competence**

This part asked the students to check their progress and how far they had achieved the learning process as well as how far they have implemented the traits that they had learned. As Koesoma (2007) stated, feedback and reflection greatly contributed to the learners' character building. In order to reach the objective in this part, the students were given some of the task which they need to accomplish. Those tasks actually functioned to sum up the learning material that the students had learned. In this part, peer assessment was given to the students both in the aspect of academic skills and in the aspect of characters that they need to acquire. As it



was suggested by the principle of teaching character, after the students were given the chance for implementing the character, they were expected to reflect so as to look back on what they had done. Considering the feedback from their friends, they are expected to be able to do the self reflection

### 3.2.5 Let's Make Reflection

Whereas in checking your competence the students were still given the task, in this part, the students were no longer given task. What they needed to do was only reflecting on how far they understood the learning material and how far they had implemented the character they had learned before. This part was derived from the character building's teaching that reflection greatly contributed to the character building. The students were asked to reflect by themselves. They were expected to see the good points they had made and the weaknesses they had made. After that, the students were assigned to make the plan for improving themselves.

## 4. Conclusion

This paper addressed two questions namely (1) how to develop the learning material for the students which incorporate the English language proficiency and the character development for the students majoring at official administration Grade X SMKN I Godean Sleman? (2)

In order to develop learning material for the students of vocational school majoring at official administration, the writer had conducted some steps namely (a) conducting need analysis (b) stating the objective (c) deciding the subject content (d) deciding the learning activity. The presentation of learning material which integrates the English language proficiency and character development are (a) getting ready (b) moving forward (c) act it out (d) making reflection

## REFERENCES

- [1] A.Benawa, "Pentingnya Pendidikan Karakter Intelektual," in *Educare Wahana Komunikasi Pendidikan*, vol.IV/12, 2008, pp 35 – 37
- [2] D.Koesoema, *Pendidikan Karakter: Strategi Mendidik Anak di Zaman Global*. Jakarta: Grasindo, 2007, pp 212-221
- [3] D.Koesoema, *Tiga Matra Pendidikan Karakter in Basis Menembus Fakta*, no VII, 2007, pp 19 – 23
- [4] F.Hardiman, "Pendidikan Karakter Membentuk Individu Baru" in *Educare Wahana Komunikasi Pendidikan*, vol.V/VII, 2008, pp 17 - 21
- [5] F.Marianti, *Hard Skill and Soft Skill Dalam Character Building in Basis*, noVII, 2007, pp 31 – 36
- [6] H.Mifa, *Raker MPK Regio Jabalmbang, Sekolah Menengah Kejuruan Harus Berorientasi Pada Pasar Tenaga Kerja in Media MNPK*, vol XIV/1, 1994, pp 5 – 11
- [7] N.Suseno, *SMK Menjawab Kebutuhan Tenaga Kerja Professional Tingkat Madya in Educare*, vol V/4, 2008, pp 43 – 44
- [8] R.Shultz, and G.Charles, *Education in the 21<sup>st</sup> Century*, 2011, in press.
- [9] U.Buchmann, and R.Huisinga, "Curriculum Research and Development" in *Handbook of Technical and Vocational Education and Training Research*. Bremen: UNEVOC, 2008, pp. 508 - 516
- [10] Y.Latief, *Hancur Karakter Hancur Bangsa: Urgensi Pendidikan karakter in Basis*, no VII, 2007, pp 37 – 43

# PRINCIPAL'S ENTREPRENEUR LEADERSHIP MODEL FOR STAKEHOLDERS FIDELITY, LOYALTY, COMMITMENT, AND PARTICIPATION ENHANCEMENT ON VOCATIONAL EDUCATION SCHOOLS DEVELOPMENT

**Ahmad Dardiri**

Department of Civil Engineering Education Faculty of Engineering Malang State University  
ahmad.dardiri@yahoo.com

## Abstract

The Purpose of this qualitative research was identify how principals was implemented his/her entrepreneur leadership for enhancing stakeholder's fidelity, loyalty, commitment, and participations on vocational education schools program's development. The research data gathering was conducted at Public Vocational High School 6 Malang and Privat Vocational High School PGRI 3 Malang using indept interviews, observasions, and documentations. The research informan are: principals, vice principals, teachers, head of department, head of laboaratorium, school's commitee, parents, and students.

The results of the research show that implementing of entrepreneur leadership model have been enhanced fidelity, loyalty, commitment, and participations of the stakeholders on vocational educations schools programs development. Principals have implemented his/her leadership with: (1) build entrepreneurs vision and mission development, (2) gived entrepreneur motivations and inspirations, (3) developed communications and informations exchange intensively with stakeholers, (4) build quality based entrepreneur climate culture, and (5) used collaborative-participatif decision making. Principals was implement managerial focused on: (1) creative and innovative teaching learning proccess quality improvent, (2) providing infrastucture base on industrial need or teaching factory, and (3) giving excelent services for stakeholders satisfy. Despitefully, principals was promoted his/her differentiation of schools quality as school brand.

**Keywords:** Principal, leadership, entrepreneur, fidelity, loyalty, commitment, vocational education.

---

## 1. Introduction

Vocational High School (VHS) has a strategic role to prepare high quality of the middle-level skilled manpower required by the community/industry. High quality vocational school graduates will support the industrial productivity and ultimately improve national productivity. But government policies implemented for nearly six decades that prefers General High School graduated compared to VHS leads most of the secondary school graduate to choose the General High School than the Vocational High School. The VHS input has a lower quality than the high school input. Society still views VHS as a less prestigious/quality education. The impact to an educational system which consists of input-process-output, low quality of inputs carry implications for the difficulty of handling the process or obtaining the high quality of output.

Use Ref. [1], Ref. [2], Ref. [3], Ref. [4], Ref. [5], Ref. [6], and Ref. [7] Vocational High School images in the view of stakeholders is still low. Appresiation and fidelity of the industry towards vocational education graduates is still low. Besides

participating of industrial sector on vocational education in Indonesia is still low Ref. [8], Ref [9], Ref. [10], Ref.11. Ref. [12], and Ref 13.

Use Ref. [14], Ref [15], and Ref. [16] the principles of vocational education requires VHS to implement the workplace learning/dual ssystem Then the school should cooperate with the industry. The principal must be able to convince the industry so that industry has the fidelity and commitment to support the preparation of vocational school graduates as a candidate for a high quality workforce. The principal should be able to communicate the excellence of school to the industry so that industry has the trusty and willingness to support vocational education programs. However, the capacity of leadership of VHS is still low Ref. [17], Ref. [18], Ref. [19] Government policies to improve the quality of VHS has been done through various programs (1) Building the principal's capacity, (2) Promoting VHS through mass media, (3) Bbuilding an International Standard of VHS, (4) Changing the ratio of VHS : high school of 30 : 70 to 70 : 30 Ref. [20], Ref. [21]. However, the effectiveness and outcomes of the program is still questionable.

The principal is a one of important factor in achieving the quality of schools. The school principal role is to determine and disseminate the vision and mission to stakeholders. The principal role is to expands all resources to achieve goals effectively and efficiently. The principal also serves to be a motivator and inspirator for the followers to be able to display the best performance so that the school obtain optimal results use Ref. [22], Ref. [23], Ref. [24]; use Ref. [25].

Relevant researches that has been done include: Ref.[26]; Ref. [27]; Ref. [28], Ref. [28], Ref. [29], Ref. [30], Ref. [31], Ref. [32], Ref. [33] and Ref. [34]. From various research studies concluded that the model of transformational leadership is an ideal model for the implementation schools principal leadership. Use Ref [35] Marks and Printy asserted that to gain the best teachers & students performance, tranformational leadership is important but it is not enough. Principal have to fusing together tranformational and instructional leadership.

Thereby principals have to creative and innovative to make changes and develop the quality of schools and enhance the image of her/his VHS to the stakeholders in order they will have trusty, loyalty, commitment, and support for vocational school in the educational development programs.

For VHS, obtaining a positive image as a excelent school from community and industry is an important part. Good image will provide benefits to schools including: (1) to facilitate vocational school goals, (2) to increase the fidelity in the industry to support the learning process and graduate recruitment through cooperation, (3) to gain the community support for the schools, and (4) to give pride for the stakeholders at the school. Ref. [36] The vocational school image building is the duty and responsibility of principals. principals accused to have creative and innovative power so that the vocational schools able produce high quality graduates who are qualified and have a superior personality traits that fit the needs of industry.

## 2. Research Methods

This study used a phenomenological qualitative approach with multi-site design. A qualitative approach was chosen with the object of rational study of social phenomena that are not manipulated and the data revealed in the form of words, sentences, and documents use Ref. [37]; use Ref. [38]. The design of multi-site selected to obtain complete information about the implementation of entrepreneur leadership in selected case.

Research location chosen is Public Vocational High School (SMKN) 6 Malang and Private Vocational High School (SMK) PGRI 3 Malang. Both schools are the best school in Malang City and have a positive image in society (Department of Education Malang, 2008; <http://www.depdiknas.rekap.school.maping.htm>).

Use Ref. [38]; use Ref [39]; and use Ref. [40] data were collected through interviews, documentation, and observation. Determination of informants conducted with a purposive sampling technique, the internal sampling, time sampling, and snowball sampling. Informants were taken between the other principals, vice principals, teachers, education personnel, school committees, parents and students. Determination of the number of samples based on the adequacy of data and information needed.

Data analysis was done repeatedly and continuously between data collection and analysis, both during data collection in the field and after the data collected use Ref. [41]. The data obtained then will be examined for the credibility and validity with a triangulation technique of data source, member check, and peer discussions.

## 3. Results and Discussion

Data taken from SMKN 6 Malang and, SMK PGRI 3 Malang shows the principal entrepreneur leadership model in improving the image of RSMKBI include (1) the development of entrepreneur vision and mission, (2) the provision of entrepreneur motivation and inspiration, (3) development of quality culture, (4) relationship development, and development of intensive communication exchange of information with stakeholders, and (5) collaborative and participative decision making.

Wadib Su'udi, principal of SMKN 6 Malang stated:

"... The first step that I do to make Public Vocational School 6 as RSBI is expand the friend's view about how to work properly. The first step that must be taken to achieve superior image of the school is to achieve accreditation of schools with target A. Therefore, learning is the top priority. The essence of the education quality is in the process of learning".

Fatah Nasikh the Vice Principal of SMKN 6 Malang stated the following:

".. Pak Wadib (principal) always encourage people to innovate and schools to develop creativity and motivate them to take advantage of free time to entrepreneurship ". In addition, school principals also provide a challenge to those who want to advance and develop. ... principal's school always

invites residents to work hard, passionate, and have high confidence in the success of any business. "

Guntur Dwiyono the 2<sup>nd</sup> Vice Principal of SMKN 6 stated: " The principal always support us whenever we have good ideas and motivating the teachers to think more than anyone else. That's what makes this school is always innovative. Every year there is always a result of innovation generated by the teachers ".

Samsudin the Representative Manager ISO of SMKN 6 Malang also stated that the principal always encourages the entire school to do innovative works. Samsudin said: "... teachers who have good performance continues invited to work to improve the competence and career development in schools. While that did not want to forward it had to be left ".

Santur Hidayat the principal of Private Vocational School PGRI 3 Malang noted that to achieve the vision of schools as disciplined school, the system and organization of the school are being innovated such as: (1) student recruitment system, (2) Apprenticeship and graduates career system, and (3) curriculum based on the industrial needs.

The Public Relation of PGRI SMK 3 Lukman Hakim, reveal opinions as follows.

"... We are a private school, so for us the image of the school is very important. Today people still see the private vocational school as a "second-class schools" so we want to make changes. We saw a gap from the existing vocational school, that the most problematic is the handling of the graduates. We have to be a school that can provide jobs for graduates. Therefore, we formed a partnership with business and industry of all aspects ".

"... We have a strong apprenticeship program so that the industry will be able to know the style, knowledge, and attitude of our students. We introduce the quality of our students so that the industry really know the quality of our students ..."

"... The school placement of graduates is very effective for imaging. There are many students of SMK PGRI 3 which recruited by the industry before third grade that given a scholarship donations for Educational Development (SPP) during the third grade, and some have already given a full salary with a status of "On The Job Training"... this will increase the community trust upon us. On the other hand the industry is also has a network and relationships so that they act to recruit these graduates PGRI 3 eventually becomes effective imaging media. Another aspect is the knowledge and understanding of parents of school services will provide word of mouth information upon parents and other people ".

The principal must show strong leadership that has a clear vision, able and willing to empower all of the followers, able to organize well, able to

inspire, integrity, orientation far ahead, and to maintain harmonious relations with individual goals Use Ref.[41]. Vision is a future goal or purpose to be achieved by educational institutions. Vision is a direction that will be achieved by each institution. The clearer vision of the school, the easier it is for principals to make a map of travel (road map) to achieve it. The headmaster's duty is to develop and convince a vision and mission to every stakeholders. With a strong understanding of the vision, obtaining overwhelming agreement, commitment, loyalty and passion are easy to achieve. Each stakeholder will be convinced that by achieving the purpose of education, prosperity will be provided for all.

In the works of entrepreneur leadership, the principal have managerial functions that include (1) managing school resources, (2) managing the school infrastructure, (3) manage the partnership with industry, (4) managing finances, and (5) supervision.

The headmaster of SMKN 6 Malang, Wadib Su'udi stated:

"... I want to make SMKN 6 Malang as a small but complete school, so I make an artificial forest inside school. Because we have many guests from the national industry and abroad, I make a Guest House so that the guests from the industry do not have to stay at expensive hotel. That will make the industry happy. School has a basketball court, that we always paint it so it gives a good mood and excitement. Many people love to see the field which is always in a good condition.

"I want a change in school, then I created a gazebo on the second floor to gives a beautiful impression. I will also build a swimming pool. The important thing is to keep the environment arranged as a comfortable and beautiful place".

Santur Hidayat, principal of the SMK PGRI 3 Malang said that industrial apprenticeship has a role in assessing the results of practice, setting industry-specific competency standards, sufficing schools infrastructure up to industrial need, and certification of competency test by industry. Santur says: "... Our competency test is examined by the examiners from the industry. This is very serious, not all fair industry believe in every schools ".

The above principal state shows that the entrepreneur principal always think active and creative to make a breakthrough, so new programs will keep appear that different from other schools both in the role of a leader or role as a manager. The innovation could be related with program, system, and new activities that have more value of than that already exist.

The principal strategy in implementing the promotion is done by (1) define positioning, (2) provides branding, and (3) choose the

differentiation of products/services school. The image building process is done through direct and indirect promotion.

Use Ref. [42], Ref. [43], Ref. [44], and Ref. [45] entrepreneurship means courage and virtue in meeting the needs and solve the problems of living with the existing power of himself. Entrepreneurship refers to the nature, character and characteristics embedded in individuals who have the willpower to develop and implement creative and innovative ideas into the activities. Entrepreneurship person is someone who has internalized the values of entrepreneurship, a personality that has creative innovative actions, likes to try, brave in facing the challenge, confident, have self determination or locus control (the capability to manage risk), see the change as an opportunity, tolerant of many choices, initiative and have a need for achievement, and liberal-minded perfectionist, think that time is precious, and have a strong motivation to excel.

Being an entrepreneur principal means being a principal that has the willingness and ability to find and evaluate opportunities, gather the necessary resources and act to take advantage of that opportunity. The principal willing to take calculated risks and enjoy challenges with moderate risk. A principal that has entrepreneurial spirit will be full of confidence and determination in himself and his ability to make the right decision.

Characteristics of entrepreneurship involves three dimensions include innovation, risk taking and proactive. Innovation refers to the development of products, services or unique process that involves a conscious effort to create a particular purpose, focusing on the potential socio-economic change organization based on individual creativity and intuition. Risk-taking refers to an active willingness to pursue opportunities. While the proactive dimension refers to the assertive nature, the constantly searching of new opportunity market and experimenting to change the social environment.

The ability of entrepreneurial principal in innovating will determine the success in schools led by him because he is being able to addressing the needs, desires and expectations of society on education services for their children. Thus, if the entrepreneurs minded principal wish to lead the school he should be creative and innovative individuals in realizing the potential of creativity into the form of valuable innovation of the school

Trusty, loyalty, commitment and participation of the stakeholders to the both schools were high level. Public interest to enter in SMKN 6 Malang and SMK PGRI 3 Malang each year was increase continously. Many industry was supported in the

implementation of education at the both schools. They do not have difficulties to students take place in the apprenticeship activities. Indeed at the end of the apprenticeship many students from both schools have been recruited as workers by industries.

Entrepreneur work culture has been developed in both schools. It was observed from many innovative and creative teaching-learning, many developed of innovative product as teaching factory by each department in the SMKN 6. Even in the 2011 years principals was decided to be build the "School Business Center".

Creativity and innovation of SMK PGRI 3 Malang was showed (1) implementing of the curriculum based industrial needs, (2) encouraging many industry to implement of the workforce education training through their curriculum at the school, (3) empowering teacher-students-parent communication system. The impact of those programs 70-80% of the graduates have obtained a job working in industries.

#### **4. Conclusion**

Implementing the principal's entrepreneur leadership model of Vocational High School was enhance stakeholders fidelity, loyalty, commitment, and participation vocational education schools development.

The principals have implemented his/her leadership with: (1) build entrepreneur vision and mission development, (2) gived entrepreneur motivations and inspirations, (3) developed communications and informations exchange intensively with stakeholders, (4) build quality based entrepreneur climate culture, and (5) used collaborative-participatif decision making. Principal's was implement managerial focused on: (1) creative and innovative teaching learning process quality improvent, (2) providing infrastucture base on industrial need or teaching factory, and (3) giving excelent services for stakeholders satisfy. Despitefully, principals was promoted his/her differentiation of schools quality as school brand.

#### **5. Future Works**

For Ggovernment:

- [1] Government (Directorate of Vocational Education Management Development or Educational District Official have to mapping of teachers entrepreneur leadership. Hence this information use to enhancing leadership development program.

- [2] Government and college make collaborative to disseminate the research invention
- [3] Government and college make collaborative work to developing module/material/guide of entrepreneur leadership course training.

For Reseacher:

- [1] Researcher have to developing instrument principal entrepreneur leadership practice model in order principal can his/her self evaluation.
- [2] Researcher have to continuing principals entrepreneur leadership model with focus on entrepreneur character building of vocational high school teachers.

### REFERENCES

- [1] [http://www.padangexpres.co.id/content/view/7657/142/14\\_juli\\_08](http://www.padangexpres.co.id/content/view/7657/142/14_juli_08).
- [2] Paryono. "Perceived image of vocational and technical education and improvement initiative". 2006. Dowloaded August, 18 2008 from: [http://www.voiced.edu.au/td/tnc/92\\_220](http://www.voiced.edu.au/td/tnc/92_220).
- [3] N. Pimpa. "Reference group and choice of vocational education: case in Thailand". AARE 2007, p 1-15. Dowloaded November, 15 2008 from: <http://www.aare.edu.au/07pap/pin07613/pdf>.
- [4] Harris, R., Simons, M., & Moore, J. (2005). "A huge learning curve TAFE practitioners ways of working with private enterprises". Dowloaded May, 15 2008 from: <http://www.ncver.edu.au>.
- [5] Greenwood. "We are still stuck and in agroove of thingking that the practical vocational course are inferior to more academic studies p 407, 2005. <http://www.proquest.com/pqdweb>.
- [6] Dinas Pendidikan Kota Malang. [http:// www.psb.online.or.id](http://www.psb.online.or.id).
- [7] Roadmap PSMK 2005-2009.
- [8] Caldwell, B. Successful learning and the globalization of learning In P Harlinger (Ed)., Reshaping the landscape of school leadership development. A Global Perspective. Lisse, Netherlands: Swets & Zeitlinger. 2003. pp.23-40.
- [9] S. Dinham. Principal leadership for outstanding educational outcomes. Journal of Educational administration, 2005. 43) 4/5. h. 338. Dowloaded August, 18 2008 from: <http://www.proquest.com/pqdweb>.
- [10] Vocational Education's Image for the 21st Century. Eric Education Report. Dowloaded September, 18 2008 from : [http://findarticles.com/particles/mi\\_pric/is](http://findarticles.com/particles/mi_pric/is).
- [11] J. Prasetyo."Tingkat pengangguran smk paling tinggi". <http://www.surya.co.id/2009>.
- [12] A. Dardiri. "Sikap siswa sekolah lanjutan tingkat pertama terhadap sekolah menengah kejuruan". Jurnal Penelitian Kependidikan (9) (2). 2001. p. 156-166.
- [13] W. Djojonegoro. Pengembangan Sumber Daya Manusia Melalui Sekolah Menengah Kejuruan. Jakarta: PT Jakarta Agung Offst.1998.
- [14] J.A. Raelin. Work-Based Learning. Bridging Knowledge And Action In The Workplace. San Fransisco: Josey Bass. 2008.
- [15] J. W. Rojewski. "A conseptual framework for technical and vocational education training" in Wilson, D & Macleon, R (Eds.), International Handbook Of Educationa For The Changing World Of Work. Bridging Academic and Vocating Learning. Bonn: UNEVOC Springer. 2009.
- [16] Surya Dharma. Kepala sekolah dan pengawas di Indonesia belum memenuhi syarat uji kompetensi. <http://www.kompas.com/read/xml/2008/08/11>.
- [17] Republika. July, 2 2009.
- [18] Kendari Pos, August, 22 2008.
- [19] Roadmap PSMK 2005-2009.
- [20] Tan, B. (Juni 2007). Rebranding vocational education in Singapore: ITE's experience. Paper presented in Public Relation Academy Conference "Markets and Brands: Positioning for the 21 st Century. Singapura. Dowloaded November, 02 2008 from: <http://prspeak.wordpress.com/2007/06/19/rebranding-vocational-education-in-singapore-ites-experience/>
- [21] Catri. D. B. (1998). Vocational education's image for the 21st century. Eric educational report. Dowloaded Augst, 18 2008 from <http://findarticles.com org/1999-2/21st.htm>.
- [22] Creswell. J.W. (2009). Research design: qualitative, quantitative, and mixed methods approaches. Third Edition. Los Angeles: SAGE Publications.
- [23] C.A. Walker. "Effective leadership. Twelve words to lead by. Twelve words to live by". La vergne: USA. 2005. p 12. Dowloaded Februaryy, 2 2011 from: <http://www.wclct.com/effective-leadership/2.1.pdf>.
- [24] T.J. Sergiovani and D.L Elliot. The Principalsip: A Relective Practice Perspective. p. 89. Boston: Allyn bacon Inc. 1987.
- [25] Yin Cheong Cheng. New Paradigm For Re-Engineering Education. Globalisation, Localitation and Individualisation. Netherland: Springer. 2005
- [26] H. Usman. Manajemen Teori, Praktik, Riset Pendidikan. Jakarta: Bumi Aksara, 2009.
- [27] N. Pimpa. Reference group and choice of vocational education: case in Thailand. AARE 2007, p 1-15. Dowloaded November, 15 2008 from: <http://www.aare.edu.au/07pap/pin07613/pdf>.
- [28] D. Mulcahy. Leadership and management in vocational education and training. Australian Government, 2003. NCVER. Dowloaded, July, 20 2009: <http://www.ncver.edu.au>.
- [29] J.M. Kouzes and B.Z. Posner. The leadership challenge: How to keep getting extraordinary things done in organizations. SanFrancisco: Jossey-Bass, 2005.

- [30] M.L. Kruger, B. Witzier, and P. Sleeper. The impact of school leadership on school level factors: Validation of a causal model. *School Effectiveness & Improvement*. Vol 18 (1) 1-20. 2007.
- [31] I. Falk. Designing effective leadership interventions: a case study of vocational education and training. *Leadership and Organization Development Journal*, 24 (4): p.193-203. 2003. Downloaded: July, 18 2009 from: <http://www.informaword.com/>.
- [32] Toharudin. Kepemimpinan Kepala Sekolah dalam mengelola SMK Bertaraf internasional. Studi Multi Kasus di SMK Negeri 3 Malang dan SMK PGRI 3 Malang. Disertasi. Unpublished. Malang State University. 2008
- [33] Wellman, W., Perkins, G., & Wellman, N. "Educational leadership: the relationship between spirituality and leadership practices". *Academic Leadership online Journal*. Downloaded July, 25 2009 from: [http://www.academicleadership.org/empirical\\_research/579.shtml](http://www.academicleadership.org/empirical_research/579.shtml).
- [34] Syamsul Hadi. Kontribusi Kompetensi Emosional Dan Praktik Kepemimpinan Transformasional Kepala Sekolah Terhadap Keberdayaan Guru Pada Sekolah Menengah Kejuruan Di Malang Raya. Disertasi. Unpublished. Malang State University, 2009.
- [35] H.C. Marks and S.M. Printy. "Principal leadership and school performance: an integration of transformasional and instructional leadership". *Educational Administration Quarterly*, Vol. 39, No. 3, 370-397, 2003. Downloaded October , 26 2009 from: <http://eaq.sagepub.com/cgi/content/abstract/39/3/370>.
- [36] C. Gronroos, *Innovative Market-ing Strategies and Organization Structures For Service Firm*. Working Paper, Swedish School of Economics, Helsinki, Finland.
- [37] Bogdan, R. & Biklen, S. K. *Qualitative research for education : an introduction to theory and methods*. Boston: Allyn and Bacon Inc, 1982.
- [38] Sugiyono. *Metode penelitian kuantitatif, kualitatif dan R & D*. Bandung: Penerbit Alpha Betha, 2006.
- [39] E.G. Guba and Y.S. Lincoln. *Effective evaluation*. San Francisco: Jossey Bass Publisher, 1981.
- [40] Sukardi. *Penelitian kualitatif-naturalistik dalam pendidikan*. Yogyakarta: Penerbit Usaha Keluarga, 2005.
- [41] Bogdan, R. & Biklen, S. K. *Qualitative research for education : an introduction to theory and methods*. p. 46 Boston: Allyn and Bacon Inc, 1982.
- [42] H. Usman. *Manajemen teori, praktik, riset pendidikan*. Jakarta: Bumi Aksara, 2009.
- [43] A. Buchari. *Kewirausahaan*. Bandung: Alfa Beta.2006.
- [44] Hisrich, R.D. & Peters, M.P. (2002). *Entrepreneurship*. Fifth edition. New York: McGraw Hill Irwin.
- [45] Hakim, R. (1998). *Dengan Berwiraswasta Menepis Krisis: Konsep Membangun Masyarakat Entrepreneur Indonesia*. Jakarta: Elex Media Komputindo.
- [46] A. Winarno, "Pengembangan model pembelajaran internalisasi nilai-nilai kewirausahaan pada SMK di Kota Malang." *Jurnal Ekonomi Bisnis Tahun 14 No 2*. (124-131). 2009.

# MULTI-CONNECTION PHONE-BASED MOBILE INTERNET TO SUPPORT E-LEARNING AND ICT LITERACY FOR RURAL COMMUNITY

Eko Marpanaji<sup>1</sup>, Herman Dwi Surjono<sup>2</sup>, Suprpto<sup>3</sup>, Kadarisman Tejo Yuwono<sup>4</sup>

<sup>1,2,3,4</sup> Electronics Engineering Education, Engineering Faculty, Yogyakarta State University  
<sup>1</sup>[eko@uny.ac.id](mailto:eko@uny.ac.id), <sup>2</sup>[hermansurjono@uny.ac.id](mailto:hermansurjono@uny.ac.id), <sup>3</sup>[suprpto@uny.ac.id](mailto:suprpto@uny.ac.id), <sup>4</sup>[arispra@uny.ac.id](mailto:arispra@uny.ac.id)

## Abstract

This research aims to assess alternative technologies in developing mobile Internet system using mobile phone. This system is needed to improve information flows in rural areas. Location of this research is limited to rural areas in Daerah Istimewa Yogyakarta (DIY) Province. The system studied is a Multi-connection Phone-based Mobile Internet (MCPMI) using cellular modem, by implementing load balancing so that the Quality of Service (QoS) is quite high. In addition, this research conducted a survey to obtain information on the extent of Internet access service using mobile phones has reached rural areas in DIY Province. The problem includes how to perform server load balancing for mobile Internet, how the performance of the server, and how the map of Internet access service using mobile phones. The results of this research are a prototype of Rural Internet Access Service Map and a prototype of Multi-connection Phone-based Mobile Internet Server using Zeroshell by conducting an experiment in configuration and implementation of failover or round robin load balancing. The performance testing of the prototype shows that multi-connection using two GSM modem with 500 Kbps up to 700 Kbps for each modem when downloading can generate the total bit rate of 1 Mbps up to 1.5 Mbps when downloading by implementing load balancing on two modems. Prototype of Internet Access Service Map and Multi-connection Phone-based Mobile Internet Server generated in this research is still in the form of a laboratory scale and its performance need to be tested in the field.

**Keywords:** e-learning, information and communication technology, load balancing mobile internet, modem GSM/CDMA,

## 1. Introduction

Most of the population of Indonesia is located in rural areas and the flow of information is still very slow. Internet network can be a cornerstone in improving the information flow so as to enhance the progress of the nation. However, until today the Internet access in rural areas are still very rare and even nonexistent. For that, a solution in providing Internet access service is needed by society, so that rural communities become more rapid progress.

Internet access using VSAT is an alternative to realize the Mobile Internet access services [1]. However, the investment and operational costs are quite expensive so that it is not in accordance with the conditions in rural areas. Another possibility is the Internet access using cell phones, because until now most of the rural areas including rural areas in Daerah Istimewa Yogyakarta has been attached many Base Transceiver Stations (BTS) of the various cell phone service providers.

Currently mobile phone devices has been widely known and used in rural communities. However, these devices have not been widely used for Internet access because the costs are still quite expensive and given bit rate is still limited. In addition, mobile phone devices with features that support for Internet access (3G) can not be owned by the rural community at large, as well as access

the Internet using a mobile phone has limitations because the size of the screen is too small making it less comfortable. Thus, there is need for alternative technologies to assist rural communities to recognize and use the Internet.

Another urgency of this research topic is the ability of communities to use information and communication technology (ICT), especially Internet access that is still very low, so that it needs guidance in using information and communication technology, especially in terms of Internet access.

This research aims to assess alternative technologies in developing mobile Internet access service system for rural areas. Systems studied are Multi-connection Phone-based Mobile Internet (MCPMI) uses Global System for Mobile Application (GSM) modem or Code Division Multiple Access (CDMA) modem by implementing load balancing.

Internet access using cell phones was started using Wireless Application Protocol (WAP) technology in the 1990's for 2nd generation (2G). WAP is a protocol used to access the Internet using mobile phone networks such as World Wide Web (WWW) technology using the Hyper Text Transport Protocol (HTTP). WAP supports various types of mobile phone technologies including GSM and CDMA. WAP using GSM technology has a bit



rate of 9.6 kbps, and 70 up to 80 kbps using CDMA 2000 1x technology.

The main issue in accessing the Internet data using WAP is data access speed (bit rate). GSM mobile phone developed a General Packet Radio Service (GPRS) with bit rates up to 153 kbps and then called with 2.5 G. Furthermore, Enhance Data Rate for GSM Evolution (EDGE) is used as an improvement of the GPRS and has a bit rate of 384 kbps. EDGE is used as the basis for the emergence of 2.75 G. Third generation (3G) use High-Speed Downlink Packet Access (HSDPA) with 14.2 Mbps as part of High Speed Packet Access (HSPA) family that has 14 Mbps in the downlink and 5.76 Mbps in the uplink. On the other hand, CDMA technology developed a data access technology namely 1xEV-DO or EV-DO with a bit rate of 2.4 Mbps [2] [3].

The investigated MCPMI services are expected to be used to enhance the ability of communities to use ICT to enhance the readiness of rural communities in the global competition. MCPMI system can also help create a connected society, so that information flows more smoothly and the welfare of rural communities is better.

Internet access technology in the research is geared toward rural communities, given that most of Indonesia's populations reside in rural areas and many areas are categorized as remote areas or are separated from the world of information. Thus, the system developed can be used as a means to assist governments in improving the ability to use Information and Communication Technology tools for the community even to people who live in rural areas.

Research on MCPMI system is expected to generate an alternative technology in building a system of Internet access without cable and phone-

based multi connection mobile phones using load balancing.

The system can also be developed for a learning tool for students of schools in rural or isolated areas that do not have Internet access especially in the task of learning ICT, both for elementary school (SD) or High School (SMP) or higher. This study is limited for rural areas in Daerah Istimewa Yogyakarta (DIY).

## 2. Research Method

The system under study is MCPMI system uses GSM/CDMA modem by implementing load balancing so that it can overcome the problems of Quality of Service (QoS), especially the amount of bit rate offered. The problem is how far the availability of facilities Internet connection using cell phones in rural areas of DIY, how the architecture of hardware and software needed, how to perform load balancing, and how the resulting system performance, as well as web content such as what can still be served by such a system is feasible.

This research activity is divided into several activities, namely: (1) survey the availability of Internet access services in some rural areas in DIY in order to obtain information types of hardware (modems) that can be used or a map service, (2) testing the MCPMI architecture and performance; and (3) what if the system is applied to access e-learning and the introduction of information and communication technology in rural areas.

Activities (1) and (2), conducted in First Year, while the activity (3) will be implemented in Second Year. This paper discusses the activities of First Year of mapping services, prototyping and testing the MCPMI. The hardware architecture used to build a system MCPMI shown in Figure 1.

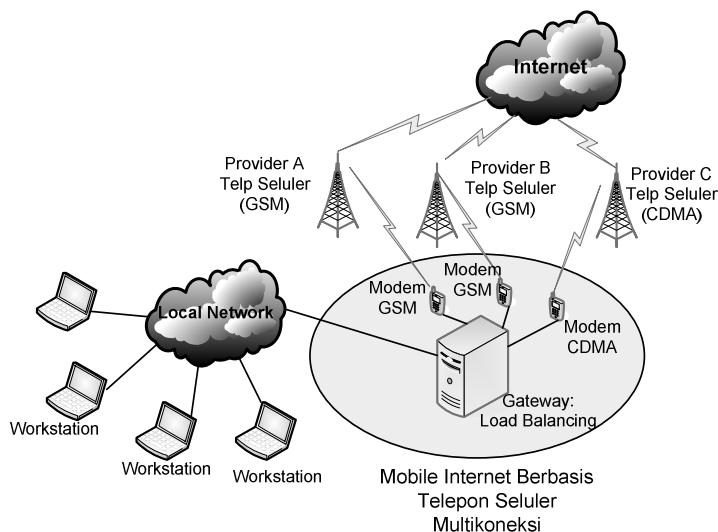

Figure 1. Hardware architecture of MCPMI.

### 3. Result and Discussion

#### 3.1 Mapping of The Internet Access Service

Mapping the Internet access service for some mobile phone service providers with GSM or CDMA technology was done to prove what they have offered in their promotion. Activity of mapping bit rate Internet access services performed in this study begins by browsing the Internet to obtain information map of Internet access services to some good cell phone service providers that use GSM or CDMA technology.

Activities that have been conducted are data collection in some points especially in a district of Kulon Progo, Bantul, Sleman, and Gunung Kidul. Based on the observations, most rural areas have a minimum of affordable Internet access service even with the GPRS technology (for GSM) and CDMA 1x (for CDMA). While in some areas close to the District Office, most of them can enjoy 3G services in the form of Internet access with HSDPA or HSPA technology.

Based on these results the condition of each district in the Daerah Istimewa Yogyakarta can be explained as follows.

The area of Sedayu sub-district of Bantul has gained Internet access services using HSDPA, even though the signals obtained are still small (one bar), while for CDMA technology with the Internet access services using EV-DO have a very strong signal (2 to 3 bar). Kulon Progo district, especially

Pengasih sub-district still using EDGE technology (for GSM) and CDMA 1x (for CDMA). Nevertheless, some areas located near the district town have HSDPA signals, such as Wates city and regions of Kulon Progo Dam.

Sleman district in general have enjoyed Internet access using HSDPA service, although for some areas away from the city district is still using EDGE or GPRS technology. Some locations in Gunung Kidul's got Internet access service using 3G technology (HSDPA), while for the southern region (near the south coast) still uses GPRS technology and even cell phone signals is negligible.

Mapping of the Internet access service in rural areas which is implemented in the form of DIY Map web-based Internet Access Service Information System provides information on: (1) the geographic location of rural areas based on GPS data; (2) types of mobile phones for the connection (GSM /CDMA); (3) types of data access services technology which is GPRS/EDGE/HSDPA/HSPA for the type of mobile phone GSM and CDMA 1x / EV-DO for CDMA cellular phone types.

Data obtained from the field is then inserted into the Map Internet Access Service Information System that is built using Drupal and Google Map [4][5]. The display of data access Internet information system using mobile phones can be seen in Figure 2 below.

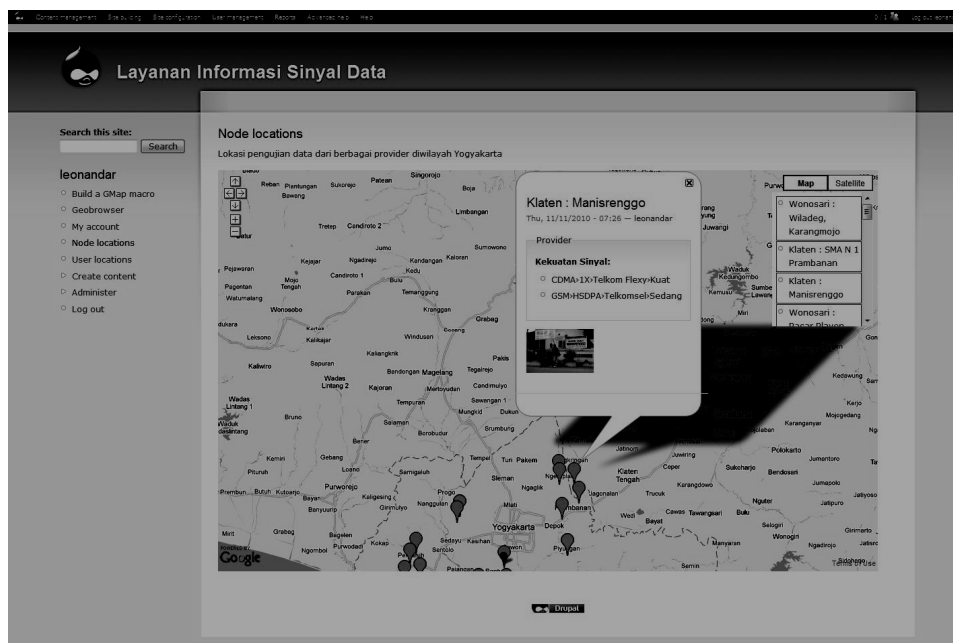

Figure 2. The web-based Map Information System of Internet Access Service mobile phone in rural areas of Daerah Istimewa Yogyakarta.

### 3.2 Server Gateway IBMCCP

The MCPMI Server gateway in this study was developed using the Linux operating system and open source software in the process of multi connection load balancing. The reason for selecting the Linux operating system is the freedom of licensing factor and network system security. Linux operating system is the operating system most widely used in building a server that is connected to the Internet because it does not require a license in its use. In addition, reliability and security of a proven system guaranteed and any problems or bugs can be consulted to find a solution via the Internet easily.

In balancing the load of multi connection to the internet, it has been developed including open source Linux-based software. Zeroshell in this study has been chosen to do load balancing for several reasons, among others: (1) an open source software; (2) based on Linux; (3) user interface already allowing administrators make arrangements; (4) can handle multiple connections using GSM or CDMA modem which is limited although some types of modems; (5) settings which can be done via the client computer with a web-based connection facilities so as to facilitate the setting remotely.

Zeroshell used in this study is a Beta version of the application program, so it is still an opportunity to make changes or additions to the module according to the needs and source programs can be downloaded for free.

Zeroshell does not need to be installed, but it can simply be run in several modes, namely: (1) Boot CD; (2) Boot CD trough VMWare; (3) Boot using Flashdisk; (4) Install directly in Hard disk. All kinds of software can be downloaded from the address <http://www.zeroshell.net/eng/download/>. After finishing the download, Zeroshell can be burnt directly on CD or be run directly Vmware (Zeroshell downloads special for VMware).

This study uses the boot mode CDs which are installed on personal computers. This mode is considered more practical, although it need precision (burning speed selection and the quality is pretty good CD burner) when burning a CD so that CD burning can process the boot perfectly. It also tried to install stick the boot mode in the notebook as an alternative and increasing levels of mobility server.

To run the Zeroshell, it needs to be convinced first that the device connecting to the Internet as a modem GSM / CDMA, ADSL and others have been connected to the server. Thus, when the Zeroshell performs the boot process, it can run automatically each of the modem drivers that can be recognized. This study uses two modems of Sierra 881U with Telkomsel Flash Internet access services because those services have the APN as a major requirement to use Internet connection Zeroshell.

Internet connection service that does not use the APN will not be recognized by Zeroshell. Stages in the running Zeroshell briefly are as follows:

1. All GSM/CDMA modems are already installed on the computer.
2. Booting a gateway server using the life-CD ZEROSHELL and wait until boot process is completed.
3. Setting an IP Address. Default IP Address Zeroshell is a class C which is 192.168.0.75 with a netmask of 255.255.255.0. Thus, all client computers must be set the IP address used is the class C 192.168.0.x, netmask 255.255.255.0, Gateway and DNS for client 192.168.0.75 filled. Zeroshell settings for the gateway server can be done using the client computer through a browser application program through <https://192.168.0.75> address.
4. Standard accounts for Zeroshell using the username = admin dan password = zeroshell.
5. Zeroshell settings by following the instructions on the site where open source database.
6. Testing results of the settings can be done through the Utilities menu on the left menu column. Fill in the IP Address or hostname to test the connection and then click Check. This study uses a hostname google.com with the aim of testing the function of the DNS has been configured. Display test results are as follows.
7. Figure 3 shows that the connection to google.com is successfull demonstrating the function of DNS working with existing evidence google.com resolves hostnames into IP addresses.
8. After that all clients are connected to the LAN network to surf the Internet through the Gateway service Zeroshell which has connected to the Internet using these two 3G modems.

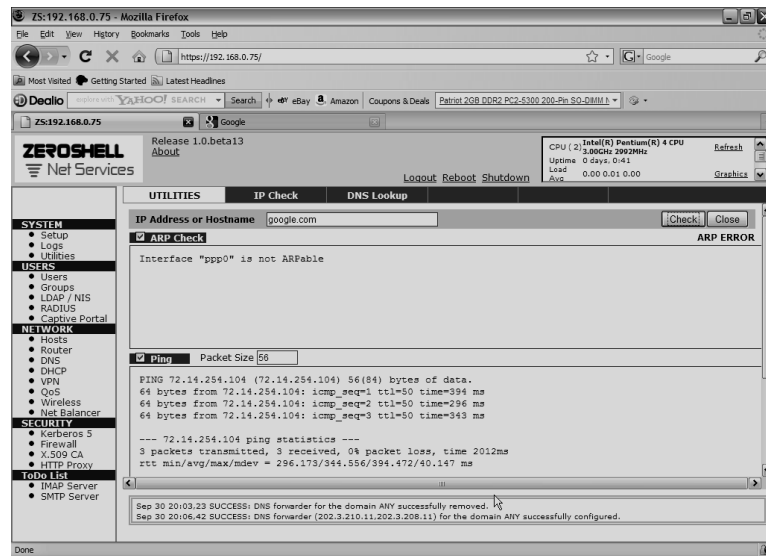

Figure 3. The display of test result

Based on test results of multi connection server load balancing using two GSM modems then the resulting bit rate is roughly 2 times the bit rate by using a single modem connection. Internet services are used in this study is an Internet service with a maximum capacity of 1 Mbps with a record of the use of Internet connections has not exceeded the allowable quota is 1 Gigabyte. Thus, the connection using two modems would generate a capacity of 2 Mbps.

Testing the average bit rate that can be obtained by using a modem with Telkomsel Flash in this experiment is 500 Kbps up 700 Kbps during downloads. So the connection using two modems will produce up to 1 Mbps bit rate 1.5 Mbps during downloads.



Figure 4. Display test results using 2 pieces of the bit rate modem

Minimum standard set of Internet services by government is 1 Kbps / user. Thus, a server with 2 pieces of this modem connection can serve approximately 1000 sd 1500 users.

If the average user want a bit rate that is more feasible to conduct an Internet connection such as a minimum threshold is 10 Kbps, the server-based mobile Internet gateway with 2 pieces of multi-modem connection can serve 100 to 150 users. Based on the analysis of experimental data shows that the server-based mobile Internet gateway multi

connection decent Internet connection is used to serve one class comprising 40 students smoothly.

If viewed in terms of bandwidth per month subscription fee, then the Internet connection by using two cellular phone modems are also relatively inexpensive, which is 2 x Rp. 110,000.00 = Rp. 220,000.00. However, the application server that has been tested in laboratory scale needs to be investigated further to determine the performance especially in the field significantly.

#### 4. Conclusions and Future Work

The conclusions of this research are:

1. The prototype system uses software MCPMI Opensource Zeroshell software that implements load balancing work well and using the N numbers of cellular telephone modems will generate N x Bit rate of each modem. Tests using 2 pieces of modem with up to 500 Kbps data service 700 Kbps each modem will generate 1 Mbps to 1.5 Mbps.
2. Subscription cost of bandwidth for each packet is used in the testing service is Rp. 110.000, - each month, so by using 2 pieces of modems require a fee of Rp. 220.000, - each month for Internet access service with bit rate of 1 Mbps up 1.5 Mbps.

Future work:

1. MCPMI server prototype is still in the form of a laboratory scale and still needs to be tested in the field to obtain a picture of system performance significantly in rural areas.
2. Method of load balancing methods is still limited to "failover" and the need to develop another method of load balancing is more optimal.

#### ACKNOWLEDGMENT

We thank Directorate General of Higher Education of the National Education Ministry for funding this research.

#### REFERENCES

- [1] Hidayat, A. & Prabantoro, G. (2005): *Mobile Internet Center Berbasis Wireless Connection Sebagai Solusi Efektif Media Pendukung Pembelajaran Aplikasi Teknologi Internet Di Daerah Terpencil*. Prosiding: Seminar Nasional Aplikasi Teknologi Informasi 2005 (SNATI 2005), Yogyakarta, 18 Juni 2005.
- [2] Rappaport, T. S. (1996): *Wireless Communication*. New Jersey: Prentice Hall.
- [3] Smith, C. & Collins, D. (2002): *3G Wireless Networks*. New York: McGraw-Hill.
- [4] Hogbin, E. J. & Käfer, K. (2009): *Front End Drupal Designing, Theming, Scripting*. Boston: Prentice Hall.
- [5] Svennerberg, G. (2010): *Beginning Google Maps API 3: Learn How to Build Lightning Fast Mapping Applications with The Latest, Totally Remade*. USA: Apress.

# **SELF-DIRECTED PROFESSIONAL DEVELOPMENT APPROACH: AN ALTERNATIVE TO ENHANCE VOCATIONAL TEACHER'S CHARACTER**

**Istanto Wahyu Djatmiko**

Department of Electrical Engineering Education Faculty of Engineering,  
Yogyakarta State University  
istanto\_wj@uny.ac.id

## **Abstract**

This paper is arranged as an ideas contribution to integrate character building into self-directed professional development for vocational teachers. The implementation of vocational education is always kept abreast of technology and workforce development. Vocational teachers have an important role in achieving the educational success in school. The professional development for vocational teachers is required continuously to accommodate changes that occur in society. Self-directed professional development approach is one of an alternative to enhance a vocational teacher's competencies in order to enriching their professionalism, learning improvement, and school improvement. In learning process, self-directed professional development has applied the principles of adult learning that covered inside the principles of character education. Developing teacher's characters can be done through activities that are useful to themselves. By implementing self-directed professional development, vocational teachers can able to plan, do, check, and act their activity needs to enrich competencies themselves that include: knowledge, skills and attitudes. Consequently, vocational teachers must report to their school management if ever they want to obtain recognition on their professional development activities that have been done. Here, the role of the teacher's characters is examined in reporting their learning achievements that have been conducted through self-directed professional development.

Keywords: vocational education teacher, self-directed professional development, character education

---

## **1. Introduction**

In the globalization era nowadays, many countries have been racing each other to compete in a various fields. A country must have started to think about how to compete among other countries in the world, especially in the advantages of human resource development rather than the advantages of its natural resources. Here, education has hold a key role, as a basic approach, in a nation-building to achieve the quality improvement of human resources development. Thus, educational achievement has influenced strongly on the nation's competitiveness.

The Indonesia's competitiveness on the global level has been increasing yearly. Reference [1] and [2] reported the Indonesia's rank in the Global Competitiveness Index (GCI) rose from 54<sup>th</sup> rank of 133 countries in year 2009 to 44<sup>th</sup> of 139 countries in year 2010. In an economic perspective, this fact indicated that education has an impotent role in improving the quality of human resources to strengthening the nation's competitiveness.

Indonesian government has been improving continuously in education policy, in terms of quality, relevance and equity. Improving the educational quality could not be separated to improving the teacher's quality its self,

because teachers have held a central role in an education development sector. The educational quality can also be affected to teachers' quality. A good quality teachers are expected be able to increase their quality in teaching. Reference [3] clarified that the core of education is teaching and learning, and teaching-learning connection works best when we have effective teachers working with every student every day. The above statement can be concluded that education can't be separated from teaching and learning activities and teachers as agent in education itself.

The Indonesian government has appreciated to a teachers as a profession that reinforced by issued of the Law Number 14 Year 2005 regarding Teachers and Lecturers. Teachers in carrying out their profession should have four competencies, i.e. pedagogical competence, personal competence, social competence, and professional competence. And also, teachers in implementing their professionalism should have an obligation to improve and to develop their academic qualifications and competence continuously in line with developments in science, technology, and art, which is often referred to the term of "professional development" or there is also a mention of "continuing professional

development". In reference [4] described that professional development refers to skills and knowledge attained for both personal development and career advancement. Individuals may participate in professional development because of an interest in lifelong learning, a sense of moral obligation, to maintain and improve professional competence, enhance career progression, keep abreast of new technology and practice.

The above statements indicate that there are various factors that influence a teacher to participate in the professional development; a sense of moral obligation is a psychological factor that can determine his or her success. Here, the role of character building is a crucial aspect to teachers' professional development. Teachers' professional development is opened to all teachers in all education levels in Indonesia. In this paper, the study will focus on one of approach type of the professional development, i.e. self-directed professional development, in terms of building a character of vocational education teachers, especially teachers in Secondary Vocational High School (VSHS).

## **2. Professional Development in Education**

Vocational education is an educational program that is always changing in accordance with a manpower and technology development. Reference [5] explained that teachers today are faced with a rapid change and a high standard demand, so that teachers require improving their skills through in-service education and training. This statement is a simple terminology of professional development, which is one form of learning that describes a movement of teachers' increased knowledge or skills. Reference [6] defined clearly that professional development is development of teachers and support staff to enhance their knowledge and understanding, and their skills and abilities to improve the quality of teaching and learning.

Reference [7] described the professional development standard is that of the opportunities teachers and other educators should have in order to learn what they need to know and be able to do in order to assist students to achieve the content standard. Professional development standards consider two dimensions: the content of professional development – that is, what teacher need to learn – and the pedagogy of professional development – that is, how should learn it. The above statements can be expressed that the professional development is required for teachers to improve their pedagogic knowledge based on standard requirements. The results of the professional development of teachers are expected to improve their teaching quality.

Similar to the above statements, reference [8] defined the professional development as “a combination of experiences that empower individual educators, educational teams, and educational organization to improve curriculum, instruction, and student assessment in order to facilitate student growth and development”. There are three the essential elements in this definition, individual educators, educational teams, and educational organization that concerned with capacity building. Capacity building does not directly affect student learning, but increase the ability of individual, groups, and school to affect student learning. The end element, facilitate student growth and development, is the ultimate purpose of professional development. Furthermore, the next three elements, improvement curriculum, instruction, and student assessment, are core elements of professional development.

Furthermore, reference [9] explained the aim of professional development is to improve the quality of education is a perfectly respectable aim in its own right, and is one that will always continue, that should always continue, whatever successes may be achieved on way. It is related to Fullan and Stiegelbaur statement in ref. [9] that educational changes depend on what teacher do and think it's as simple and as complex as that.

Based on those of the professional development concepts, the professional development that intended in this paper is to increase capacity building of teachers to improve their quality of pedagogy knowledge and subject knowledge according to the needs of teachers that related to the school context and also to enhance their professional and career. So, professional development for teachers cannot be separated between the individual development and the school improvement.

## **3. Self-directed Professional Development in Vocational Education**

Several the descriptions of professional development for teachers have been generally described in the above paragraphs. In reference [10], vocational education teachers are change agents in schools. Furthermore, reference [11] delivered the profession profile of vocational teachers, i.e. (1) teachers are teach in formal schools and they are vocational subjects, and (2) teachers have an industrial experiences in order to improve their skills and ability. This argument suggests that the vocational teachers needed to perform self-development that can be able to adapt to changes that occurred in carrying out their duties. Thus, the vocational teacher professional development is one part of personnel development that cannot be separated from the role of schools.

In reference [12], the personnel development is an important part in vocational education, especially for teachers in order to improve their skills. Personnel development is defined as all activities designed to contribute to improve the learning effectiveness and professional efficiency of teachers and staffs. Furthermore, reference [13] describes the personnel development for vocational education teachers can be done through three ways, i.e. professional development, technical development, and general development. Professional development encourages strengthening the teachers abilities that are expected to contribute in improving the educational quality. Technical development efforts to increase the technical capability of teachers so that relevant to a world work changes. General development refers to fluency in written and oral communication. The above description can be resumed that professional development refers to the teachers competencies needed for each teacher, while the technical development and general development is more specifically suited to the each teacher respectively.

Reference [14] illustrated the individual professional development in several different forms as be presented in Figure 1. These forms can be viewed on continuum from intensive individual assistance to independent development: intensive individual assistance collaboratively planned, self-directed: approved and supported, and self-directed: independent. Intensive individualized assistance is reserved for teacher who is having serious professional difficulty. It is assistance, and should be provided only until the teacher has reached a level of basic competence. Collaboratively planned individual development is appropriate for teacher who is moving toward autonomy but still needs some assistance from staff developer or colleague in planning and implementing his or her professional development. Self-directed professional development can be planned by teacher and then reviewed, approved, and supported by school, or it can be carried out independently. Independent professional development might consist of teacher participating in graduate program, conference, or network unassociated with school, or in private reading, research, or reflective writing. The above descriptions show that self-directed professional development is one of alternative approach that can be used to enhance teacher professionalism process

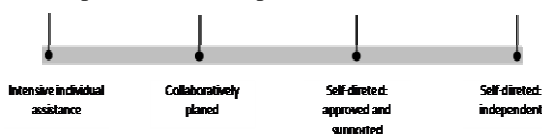

Figure 1 Individualized Professional Development on the Continuum Form (Source: Gordon, 2004:219)

Related to the professional development program for teachers, reference [15] explained that the traditional professional development programs often have focus on assisting teachers to comply with state or district directives, training in the latest teaching fad, or attempting to remediate administrator-perceived weaknesses in classroom instruction. There are six the integrating dimensions in developing the whole teacher through the professional development: self-concept and self-efficacy, cognitive development, pedagogical development, moral development, physical wellness, and integrating dimensions of teacher development. Similar statement was expressed in reference [16] that to be effective and successful, teacher professional development (TPD) must be of high quality and relevant to teachers' needs. TPD is the tool by which policymakers convey broad visions, disseminate critical information, and provide guidance to teachers. Effective TPD begins with an understanding of teachers' needs and their work environments—schools and classrooms. TPD then combines a range of techniques to promote learning; provides teachers with the support they need; engages school leadership; and makes use of evaluation to increase its impact. Essential techniques include mentoring, teamwork, observation, reflection and assessment. TPD programs should engage teachers as learners—typically involving the process of “modeling”. TPD can be divided into three broad categories: (1) Standardized TPD that is the most centralized approach, best used to disseminate information and skills among large teacher populations, (2) Site-based TPD that is intensive learning by groups of teachers in a school or region, promoting profound and long-term changes in instructional methods, and (3) Self-directed TPD that is independent learning, sometimes initiated at the learner's discretion, using available resources that may include computers and internet.

#### 4. The role of character building in the self-directed Professional Development

As described above, a sense of moral obligation is one of the factors that can influence a teacher to attend professional development. And, the self-directed professional development is one of an alternative approach of the individualized professional development that can be chosen by teachers.

Reference [16] stated that the goal of self-directed professional development is to lead teachers to identify areas for professional improvement, and then to assist them in guiding their own development in particular growth area. Furthermore, self-directed professional development was concluded that related to self-directed learning and adult learning. Self-directed



learning is based on the idea of learner control, as opposed to the role of instructions as sole decision makers. There are three factors that had to be present in order for individuals to be in control of their learning: independence to choose goals, support in the form of human and nonhuman resources to achieve goals, and personal ability required to achieve goals. Thus, teachers must have a strong character to follow the self-directed professional development.

Teachers as learners can be categorized as adult learners. According to reference [17] there are four viable definition of adult: (1) adult biologically, (2) adult legally, (3) adult socially, and (4) adult psychologically. One of the most importance of those fourth definition is the adult psychologically with regard to learning. On the other hand, the development psychology has contributed a growing body of knowledge about changes of age through the life span in such characteristics as physical capabilities, mental abilities, interests, attitudes, values, creativity, and life styles. The discussion above shows psychologically that the teachers have been implementing a learning process in domain of andragogy.

Andragogy in practice, there are six cores of adult learning principles: (1) the learners' need to know, (2) self-concept of the learner, (3) prior experience of the learner, (4) readiness to learn, (5) orientation to learning, and (6) motivation to learn [Ref. 17]. Those descriptions can be shows that adult learning in order to ensure that professional development is congruent with the teacher's need, it is depending on a character of each teacher its self. Here, the character means as such mental abilities, interests, attitudes, values, creativity that mentioned above.

In recent years there has been a return to "character education", discussions of culture and nation's character, in our nation's classrooms. In reference [19], Ministry of National Education of Indonesia in early 2010 has acknowledged the community needed on a the cultural education and the nation's character. Culture is defined as the whole a thinking system, values, morals, norms, and belief that produced human society. The thinking system, values, morals, norms, and belief are resulted from a human interaction among each other and the natural environment. Furthermore, the character is traits, morals, or personality which is formed from the internalization of various virtues which is believed and used as a basis for perspective, think, attitude, and act.

Reference [20] informed Character Counts as organization promoting character education suggested to advance character education in teaching by the Six Pillars of Character, i.e.

trustworthiness, respect, responsibility, fairness, caring and citizenship, while reference [21] had a notion that character education involves teaching children about basic human values including honesty, kindness, generosity, courage, freedom, equality, and respect. The goal is to raise children to become morally responsible, self-disciplined citizens.

Reference [21] was defined that character education is the intentional effort to develop in young people core ethical and performance values that are widely affirmed across all cultures. To be effective, character education must include all stakeholders in a school community and must permeate school climate and curriculum. Based on the practices of effective schools, they have proposed the Eleven Principles of Effective Character Education, i.e. (1) promotes core values, (2) defines "character" to include thinking, feeling, and doing, (3) uses a comprehensive approach, (4) creates a caring community, (5) provides students with opportunities for moral action, (6) offers a meaningful and challenging academic curriculum, (7) fosters students' self-motivation, (8) engages staff as a learning community, (9) fosters shared leadership, (10) engages families and community members as partners, and (11) assesses the culture and climate of the school. The above description can be concluded that the definition of character education has a different point of view among each others that dependent on the way of life their society or their nation.

Related to this paper, self-directed professional development as an enriched professionalism of teachers is expected to improve the quality of the teacher's character in learning process and after attending professional development. Based on those of statements, the characters are proposed to grow in self-directed professional development approach, i.e. awareness, honesty, respect, responsibility, fairness, caring, perseverance, self-discipline, and citizenship.

## 5. Conclusion

Implementation of vocational education is always kept abreast of technology and workforce development. Vocational teachers have an important role in achieving the success of the education in school. The professional development of vocational teachers is required continuously to teachers to accommodate changes that occur in society. Self-directed professional development approach is one of an alternative to enhance a vocational teacher's competencies in order to enriching their professionalism, learning improvement, and school improvement. In learning process, self-directed professional development has applied the principles of adult learning that covered inside the principles of character education.

Developing teacher's characters can be build during learning process and would able to put into practice in teaching and learning activities. In implementing self-directed professional development, vocational teachers can able to plan, do, check, and act their activity need to enrich competencies themselves that include: knowledge, skills and attitudes.

The character has a very broad sense depends on the community perspective on culture and trait. Through self-directed approach to professional development, teachers are possessed characters of: awareness, honesty, respect, responsibility, fairness, caring, perseverance, self-discipline, and citizenship during the learning process and after completion their learning.

### REFERENCES

- [1] The World Economic Forum, "The Global Competitiveness Report 2009–2010", Geneva: Economic Forum within the framework of the Global Competitiveness Network, 2009.
- [2] The World Economic Forum, "The Global Competitiveness Report 2010–2011", Geneva: Economic Forum within the framework of the Global Competitiveness Network, 2010.
- [3] J.H. Stronge, "A guide to Current Thinking and Best Practice", in *Evaluating Teaching*, 2<sup>nd</sup> ed. J.H. Stronge, Eds. California: Corwin Press, A SAGE Publications Company.
- [4] Wikipedia, "Professional development", retrieved June, 11<sup>th</sup> 2011, from [http://en.wikipedia.org/wiki/Professional\\_development](http://en.wikipedia.org/wiki/Professional_development), in press.
- [5] A. Craft, "Continuing professional development: Practical guide for teacher and schools". New York: Routledge, 1996, p.5
- [6] B. Sonia, "Professional Development Manual: A practical guide to planning and evaluating successful staff development", 2<sup>nd</sup> edition. London: Pearson Education Limited, 2003, p.11.
- [7] R.W. Bybee and S. Loucks-Horsley, "National science education standards as a catalyst for change: The essential role of professional development". In J. Rhoton and P. Bowers, Eds. *Professional development: Planning and design*. Arlington: The National Science Teachers Associations, 2001, p.4.
- [8] S. P. Gordon, "Professional development for school improvement: Empowering learning communities". Boston: Pearson Education, Inc, 2004, p. 23.
- [9] P. Adey, "The professional development of teacher: Practice and theory". Dordrecht. Netherlands: Kluwer Academic Publisher, 2004, p. 2.
- [10] J.W. Rojewski, A conceptual framework for technical and vocational education and training. In R. Maclean and D. Wilson, Eds. "International handbook for changing world of work: Bridging academic and vocational learning". Bonn: Springer, 2009, p. 36.
- [11] P. Grollmann, Professionalization of VET teachers and lecturers and practices in TVET institutions in an international perspective. In R. Maclean and D. Wilson, Eds. "International handbook for changing world of work: Bridging academic and vocational learning". Bonn: Springer, 2009, p. 1186.
- [12] C.R. Finch and R.L. McGough, "Administering and supervising occupational Education". Englewood Cliff, New Jersey: Prentice-Hall, Inc. 1982, pp. 135-136.
- [13] C.R. Finch and R.L. McGough, "Administering and supervising occupational Education". Englewood Cliff, New Jersey: Prentice-Hall, Inc. 1982, pp. 140.
- [14] S. P. Gordon, "Professional development for school improvement: Empowering learning communities". Boston: Pearson Education, Inc, 2004, p. 23.
- [15] S. P. Gordon, "Professional development for school improvement: Empowering learning communities". Boston: Pearson Education, Inc, 2004, p. 201-211.
- [16] V. R. Husby, "Individualizing professional development: A framework for meeting school and district goals". California: Corwin Press. A Sage Publications Company, 2005, pp. 2-7.
- [17] M. S Knowles, E. F Holton, and R. A Swanson, "The adult learner: The definitive classic in adult education and human resource development", 5<sup>th</sup> edition. Woburn: Butterworth-Heinemann, 1998, pp. 50-64.
- [18] M. S Knowles, E. F Holton, and R. A Swanson, "The adult learner: The definitive classic in adult education and human resource development", 5<sup>th</sup> edition. Woburn: Butterworth-Heinemann, 1998, pp. 64-68.
- [19] Yosephson Institute, "The six pillars of character", retrieved June, 11<sup>th</sup> 2011, from <http://charactercounts.org/sixpillars.html>, in press.
- [20] ASCD, "Character education" retrieved June, 13<sup>th</sup> 2011, from <http://www.ascd.org/research-a-topic/character-education-resources.aspx>, in press.
- [21] Character Education Partnership, "Eleven Principles of Effective Character Education", retrieved June, 12<sup>th</sup> 2011, from [http://www.character.org/uploads/PDFs/ElevenPrinciples\\_new2010.pdf](http://www.character.org/uploads/PDFs/ElevenPrinciples_new2010.pdf), in press.

# DEVELOPING THE COMPETENCE OF GRADUATES THROUGH THE IMPLEMENTATION OF A COOPERATIVE AND INTERACTIVE PROGRAM BETWEEN VOCATIONAL EDUCATION AND INDUSTRIAL WORLD

Janulis P. Purba, Ganti Depari

Universitas Pendidikan Indonesia Bandung

## Abstract

Competence as a new terminology is increasingly developing into reliable human resource development practices. The reliability of this terminology is due to its capability to prepare humans according to their basic characteristics. Competence is knowledge, skill, and basic values reflected in the thinking and acting habits of individuals on a consistent and continuous basis until they become competent in accomplishing certain works. Vocational education institution always attempts to guide and develop the profile of its graduates so that they have a competence that in turn causes them to behave effectively by superior performance under any situation. In vocational education area, the development of competence has been an urgent one, given that currently recruitment and selection, assessment of occupational performance, promotion and career arrangement are conducted based on the criteria of competence. The profile of graduate with ideal competence becomes a basis in preparing educational processes through the implementation of curriculum both in theory and in practice at vocational education institution. To improve the curriculum program, the competence of vocational educational institution's graduates can be enhanced by among others through the implementation of a cooperative and interactive program with industrial world as one of the important learning sources. The success of such program is also an achievement of industrial world as well as an achievement of the academic staff of the vocational educational institution itself. For the goal of improving cooperation and interaction with industry to be successfully achieved, the vocational educational institution should conduct an internal consolidation at first, where both institution building and image building should be accomplished.

**Keywords:** competence, vocational education, institution building

---

## 1. Introduction

The importance of preparing and enhancing human resource quality is a central topic that is widely discussed in facing industrialization and globalization era. This is due to the large need of professional workers. In line with the free trade era and the application of local autonomy that needs reliable human resource, it is time for the management of vocational education to focus their attention on efficiency, productivity, and accountability values. It also requires the availability of experts and professionals with competence to solve problems responsibly.

Currently, employment problems are too often left unresolved, because many vocational education graduates are not prepared to enter into labor markets. The existing job opportunities are not grasped by vocational education graduates. The failure of vocational education graduates to obtain a job as described above is due among others to their incompetence of reaching the "passing-grade" that has been determined by industrial world as recipient institution. That is, the vocational education graduates can not meet the required expertise or competence levels.

Competence as a new terminology is increasingly developing into reliable human resource development practices. The reliability of this terminology is due to its capability to prepare humans according to their basic characteristics. Competence is a characteristic that conveys a description on someone with respect to his or her ways of behaving, thinking, and making generalizations that are showed in a long time period (Spencer and Spencer, 1993). In a vocational education field, the development of graduates competence becomes urgent, given that currently recruitment and selection, assessment of occupational performance, promotion and career arrangement are conducted based on the criteria of competence.

To support the development of graduates competence, it needs capability of vocational education management and implementer in order to bridge and translate the policies and concepts of vocational education that are vertically accepted and implemented by field implementers to utilize industries as a learning source. The success of program and implementation by industrial world as one of the learning sources in enhancing graduates competence for vocational education is one of the

realizations of the cooperation and interaction between vocational education and industries, which is an achievement of industry world as well as that of vocational education. Therefore, there should be a goodwill of both parties.

## 2. Competence, Skill, Performance, and Standard

Competence as a new terminology is of course still more confusing as compared to other terminologies, such as skill, performance, and standard. Gonczi (1992) in Burhanudin Tola (2003: 27) says that “competence is to describe a person as competent in area of work if she/he has the knowledge, skill and attitude to be able to function at same minimum acceptable level”. Meanwhile, ASEA (2000) in Burhanudin Tola (2003: 27) says that: “Competency refers to an individual’s demonstrated knowledge, skill, and abilities performance to a specific standard”. From the definition above, it can more precisely said that competence is an attribute of an individual that is realized by actions or an individual’s performance from the result of assessment or his or her work.

Competence differs from “skill”. Gonczi (1992) as quoted by Burhanudin Tola (2003: 28) proposes that:

“skills are more specific kind of operation or performance that in combination make up the global attribute competence”. In some approaches to assessment, skills are viewed as specified and specific performance that can be directly demonstrated, observed, and assessed. Skills are best thought of as the components of competence”.

As for the meaning of performance and standard, Gonczi says that “Standard or competence is a minimum acceptable level of performance in an area of competence”. Meanwhile, Shanker (Kendall and Marzano, 1995) in Burhanudin Tola (2003: 29) defines that: standard is “what we want student to know and be able to do as result of their education”. Standard is a “performance standard” that specify “how good is good enough”.

Based on performance standard, the level of assessment on student competence may well be classified into basic, proficient, and advanced levels or other level according to the needs of assessment of an educational system. The level is called benchmarking, that education management can use as a yardstick/benchmark of achieving the competence standard of students through problems that are designed as a standard.

## 3. The Scope of Competence

In their book *Competence at Work: Models for Superior Performance*, Spencer, L.M and Spencer, S.M. (1993:9) define competence as

follows: “A competence is an underlying characteristic of an individual that is causally related to criterion-referenced affective and/or superior performance in a job or situation”.

The definition above suggests that competence is a characteristic that provides a description of an individual on how she/he behaves, thinks, and makes generalizations that are showed over a long time period. Some of the characteristics are invisible and some are visible. The invisible characteristics include motivation and behaviors, traits showed by their consistence in responding situations and information, and self-concepts (attitudes, values, and self-description). On the other hand, the visible characteristics include knowledge and skills in accomplishing any activity or duty, both physically and mentally. Meanwhile, McAshan (1981) in Mulyasa (2002) defines competence as knowledge, skills, and capability of doing cognitive, affective, and psychomotor behaviors as well as possible.

An individual’s basic characteristics that make someone effective in behaving with a superior performance under a situation is a key factor in managing human resource and it plays an increasingly important role.

Recruitment and selection, assessment of performance, promotion, and career planning are made based on the criteria of competence.

Furthermore, Spencer & Spencer identify six clusters of basic individual characteristics, namely:

1. *Achievement & Action*, concerning the characteristic cluster related to achievement and actions taken by someone in relation to goals achievement.
2. *Human and Helping Service*, the characteristic cluster related to efforts of understanding others and effort of fulfilling it.
3. *Impact and Influence Cluster*, the characteristic cluster related to efforts of influencing others to behave effectively in the interest of organization.
4. *Managerial*, the characteristic cluster as a part of the impact and influence cluster. This characteristic cluster is a specific intention (developing others, leading others, and cooperating) to exercise a certain influence on others.
5. *Cognitive*, the characteristic cluster related to one’s intellectual, capability to comprehend and solve problems or works.
6. *Personal Effectiveness*, concerning the characteristic cluster related to self-control effort to be consistently behave effectively when facing environmental pressures or difficulties.

In more details, Spencer & Spencer (1993) in Charles Sitompul et al (2003: 142-143) subdivide the six clusters into 20 types of competences, namely:

1. Achievement & Action cluster; consisting of

- four competences, namely: a) Achievement orientation, b) Concern for order, quality and accuracy, c) Initiative, and d) Information seeking.
2. Helping and human service cluster; consisting of two competences, namely: e) Interpersonal understanding, and f) Customer service orientation.
  3. Impact and influence cluster; consisting of three competences, namely: g) Impact and influence, h) Organizational awareness, and i) Relationship building.
  4. Managerial cluster; consisting of: j) Developing others, k) Directiveness, assertiveness, and use of positional power, l) Teamwork and cooperation, and m) Team leadership.
  5. Cognitive cluster; consisting of three competences, namely: n) Analytical thinking, o) Conceptual thinking, and p) Technical/professional/ managerial expertise.
  6. Personal effectiveness cluster, consisting of four competences, namely: q) Self-control, r) Self-confidence, s) Flexibility, and t) Organizational commitment.

A particular work requires persons with a correspondingly particular competence. The vocational education graduates are then hoped to be capable of accomplishing certain works in accordance with the predetermined competence standards. The profile of ideal vocational education graduates becomes a basis on which to design educational processes, such as curriculum development, educators recruitment, and available resource allocation. The profile of vocational education graduates can be formed by an aid of the concept of competences above. The preparation of vocational education graduates should, of course, involve stakeholders to get a holistic perspective on the characteristics of vocational education graduates.

Based on the definition and scope of competence as described above, it certainly needs to be followed up by its implementation through developmental process. Therefore, the characteristics of competence development include (1) emphasizing the achievement of the competence of learners either individually or in group, (2) learning outcomes and diversity oriented, (3) using varied learning approaches and methods, (4) learning sources are not only teachers, but also other learning sources that meet educative elements, and (5) emphasizing learning assessment against competences mastering and achievement targets.

To achieve the competence of learners a competence-based curriculum (CBC) approach has been applied currently as one of the approaches to determine whether the competences that are attained really explicate the tasks determined as a standard. Under the scope of this competence approach, the list of competences in form of tasks

(often used as a psychomotor tasks) is developed in accordance with the competences objectivity. The CBC is limited by one of its assumptions that capability of accomplishing a task is a demonstration of competence. The approach explains the real condition that needs performance of learners task adequately, effectively, and appropriately that can not easily be interpreted in practice.

#### **4. A Concept of Interaction between Vocational Education and Industrial World**

The objectives of industry development according to Law No. 5 of 1984 are among others: a) to improve the prosperity and welfare of people fairly and equitably by utilizing funds, natural resources, and/or cultural products and by paying attention on environmental balance and conservation, b) to promote economic growth in stages and to change economic structure toward a better, advanced, health, and balanced one, c) to enhance competence and control and to support the invention of effective technology and to develop the capacity of industrial business world, d) to provide and equalize opportunities of doing business, and e) to promote the participation of community so that they play a role more actively in building industry.

Notwithstanding the objectives of industry development above, in fact in Indonesia there are numerous, diverse industries and enterprises spreading in community. The potentials of such business and industrial world are a golden opportunity for candidate vocational education graduates, be it as a learning source for developing those competences that have been obtained in classroom and as labor markets according to their professions. Thus, vocational education should create and utilize opportunities in attempt to promote its cooperation and interaction with industrial world.

Both vocational educational institution and industrial world equally need a good, mutually beneficial interaction. However, industrial world has not yet attracted to approach vocational education, and therefore it is the vocational education that should be proactive.

In some European states, United States, and Japan, for certain times and programs, industrial world very often visits universities to select those students who are eligible to and interested in the needs of industrial world. In Indonesia, there are also some industries that did the same, but they did it sporadically.

Viewed from the needs of industrial world for enhancing the quality of their products and services professionally, both vocational education and industrial world are interdependent. Therefore, in order to promote and develop the competences of its candidate in a realistic manner, vocational

education certainly should not just wait information from industrial world, instead it should proactively search for information on what industrial world needs related to the potentials of human resource as the actors in industrial world according to their areas of competences.

### **5. Industrial World as a Learning Source for Candidate Vocational Education Graduates**

Currently, vocational education has indirectly conducted interactions and cooperation with some industries in attempt to realize its mission and the desired performance. In the context of promoting an interaction between vocational education and industrial world in order to make the latter as a learning source for vocational education graduates, there are at least four things to attend. First, the performance that has been achieved in a context of historically good cooperation between vocational education and industrial world should be promoted and improved further. The empirical experience from the implementation of interaction above is important as a means of systematic approach in order to promote cooperation. Second, the experience and historical approach vocational education has with certain industries should be followed up by a systematic approach with interaction with other industries. Third, vocational education should continuously conduct planned, continuous evaluations (such as by research), in order to reduce the barriers encountered and to eliminate those aspects in the program that are irrelevant to the existing development. And fourth, other forms of cooperation that are not yet existent conceptually but essential and highly needed should be sought in a form of programs.

To support the achievement of the four things above it needs for vocational education management to conduct the following: a) Sustainable evaluation and development of curriculum to narrow the discrepancy with technology development in industrial world, analysis of the periods of the existence of students, lecturers, administrative staffs, infrastructures/facilities, management, organizations, and finance. All the components are directed to support the concept of promoting interaction between vocational education and industrial world, as far as it is not in contrary with the prevailing legislations; b). The management of vocational education should pay a special attention on the last-year learners. They should early do so because labor market is increasingly narrowing, besides from increasingly intensive competition. The learners should be made aware to be prepared to anticipate the development of employment world in 21<sup>st</sup> century where competition is very intense, and that they should prepare themselves mentally not to easily give up and are ready to work hard. By

working hard a candidate vocational education graduate may achieve the expected competence; c) the interaction between vocational education and industrial world as a learning source for the learners of vocational education provides three functions for learners in relation to employment in community. First, to further enhance/supplement the competences obtained from vocational educational institution. Second, they get opportunity to search for employment in industrial world that is suitable with their professions. Third, there are also the graduates of vocational education who are capable of creating new employment either by themselves or in cooperation with their colleagues; d) The vocational education may spend some time specially to develop communication with its graduates that are spreading in various industries and companies. Thus, and interaction between vocational education and industrial world and businesses can be created that has a positive impact and provides opportunities for growing and developing the actualization of interaction between vocational education and industrial world and businesses.

### **6. Conclusion**

In attempt to promote the implementation of competence-based curriculum (CBC), vocational educational institution should pay more attention on the implementation of the programs of cooperation and interaction with industrial world and businesses based on the following understandings:

1. In vocational education area, the development of competence becomes urgent given that at present recruitment and selection, assessment of performance, promotion and career planning are made based on the criteria of competence. The profile of graduates of ideal competence becomes a basis in developing an educational process by implementing a competence-based curriculum, both in theory and in practice.
2. The development of competence involves: an emphasis on the achievement of competence of learners, individually and in groups; learning outcomes- and diversity-oriented; applying varied learning approaches and methods; learning source is not only teachers, but also other learning sources that meet educative elements, and emphasize learning assessment against competences mastering and achievement target.
3. Currently, vocational education has developed some cooperation and interactions with some industries, but such programs should be widened and intensified further, because those candidate vocational education graduates who conducted an on-the-job training may utilize industrial world as a learning source in developing their competences.

4. For a cooperation and interaction program with industrial world may achieve the expected objectives, the vocational education should firstly internally consolidate in which an institution building should be conducted, that is, by looking at what potential academic strengths it owns to develop, what weaknesses to solve, and what opportunities to utilize optimally.

#### REFERENCES

- [1] Mulyasa, E. *Competence-Based Curriculum*. Bandung: Rosdakarya, 2002.
- [2] Sitompul, C and Wibisono, Y.Y.: *The Competences of Unpar's Industrial Engineering Graduates*. A Paper in the Proceeding of A National Seminar on Technology Higher Education, Bandung: 2003, pages 142-143.
- [3] Spencer, L.M. and Spencer, S.M. *Competence at Work: Models for Superior Performance of United States*: John Wiley & Sons, 1993 pages 9-10.
- [4] Tola, Burhanudin. *Competence-Based Assessment*. A Paper in the Proceedings of A National Seminar on Natural Sciences Education. Bandung: HISPIAI, 2003 pages 27-29.
- [5] Law of Republic of Indonesia, No. 5 Year 1984 on Industrial Affairs, Gazette of Republic of Indonesia Year 1984 NO. 22. Jakarta: Department of Industrial Affairs.

# TECHNICAL AND VOCATIONAL EDUCATION PROGRAMS AND PROJECTS IN BANGLADESH AIMING HUMAN RESOURCE DEVELOPMENT

**Mahmud Al Haq Patwary**

Lecturer & Course Coordinator, Department of Education, DarulIhsan University, Bangladesh and International Student for Masters program, UniversitasNegeri Yogyakarta (UNY), Indonesia  
emon\_ierdu@yahoo.com

## Abstract

This paper aimed at Technical and Vocational Education of Bangladesh, and changing situation towards human recourse development and finding out the new ideas, achievements, and hindrances. Necessary data and information were collected directly from the Bangladesh Technical Education Board. The study revealed that, in creating professional labor force Technical and Vocational Education and Training in Bangladesh suffers from two types of problems; 1. Economical and infrastructural and 2.Social and methodological.

**Keywords:** human resource development by technical and vocational education in Bangladesh.

---

## 1. Introduction

Human needs and human population are increasing like nuclear fission reaction. The world economy has undergone sweeping changes in the time of a generation. The changes reflect the increased globalization of economic activities, growing competition among nations for markets and the widespread impact of the information and communications revolution. Higher productivity and economic growth are increasingly dependent on the application of knowledge and information to production of goods and services, and such knowledge is increasingly science based, as in [6]. Consequences of this scenario demands specialists in specific fields. Education is the basic need for socio-economic transformation and development of a nation, as in [5]. Conquer and survival of a nation only depends on education. It's a fundamental force and it can reform a nation strongly. Human resource development is one of the essential conditions for all kinds of growth for instance social, cultural, political, or economic, et cetera. Education is the prime constituent of human resource development. Education plays the most important role for creating trained workforce for technology and applies them in new situation. An appropriate and dynamic education system is one of the main components of all aspect of national development, as in [9].

For national reconstruction of Bangladesh, it requires the maximum utilization of its human resources. Reference [1] holds the view that Bangladesh has enough physical resources and human. The only need is educate and train its vast population to turn it into manpower and if it is done, the people of this country would be able to improve their standard of living and be prosperous

with the proper utilization of these physical resources. References [10], [11], [13] all suggest that Bangladesh urgently needs to utilize its over-crowded population and large labor market. To improve the quality of employees, Bangladesh's people need to be trained in modern professional-based and job oriented technical, technological and vocational programs.

By hearing the term 'Technical Education' the scenario emerges on general people is some complicated modern machines with some operating persons and trainees. But technical education is not exactly like that. Technical education is an age-old education. In the ancient period, this form of education was informal. But technically they were not far behind us. Technologies used in human civilization from metamorphic age to ultra-modern age. The technology used by ancient civilization has led us to this ultra-modern age where we can do almost everything without much labor.

Sad but truth is, in Bangladesh, a developing country, this form of education did not get proper importance, though it has the ability to give a boost up in the national economy. For a dynamic Technical and Vocational education system which can efficiently develop professional labor force, development, revision and reformulation are closely needed, whose can be achieved by programs and projects focusing those factors. Though ignored much, Bangladesh launched some programs and projects concerning this sector. The main concern of this literature is to give a brief description of Technical and Vocational Education of Bangladesh which is based on several programs and projects, reviewing the changing situation towards human recourse development and finding out the new ideas, achievements, hindrances and ways to overcome those obstacles towards effectively



develop human resources. This study may show a new way for the further renewal and modification of these programs and projects and probably will be helpful for under develop and developing countries who are seeking for innovation.

## 2. Technical and Vocational Education in Bangladesh

Vocational and technical education in Bangladesh is running on three tiers, as in [4], while comprises following programs:

1. Secondary School Certificate (Vocational)/SSC(voc.);
2. Higher Secondary Certificate (Business Management)/HSC(BM);
3. Basic Trades (BT) (360 Hours);

However, before starting of SSC (voc.) program, there were trade level training courses in Vocational Training Institutes (VTI) and Technical Training Centers (TTC) and mobile trade courses under Textile Vocational Institutes (TVI) e.g. National Skill Standard-II (NSS-II), NSS-III. Bangladesh Technical Education Board (BTEB) has conducted a series of studies involving internal and overseas job markets for skilled manpower and their training. Finding of these report have been created a sound base that contributed in making policy decision for introducing vocational education at the secondary level of education. Study of Job Market for Vocational Training Institute(VTI) graduate was conducted. Total numbers of skilled workers were 1, 36,706. The major findings were-

- Only 0.4% received standard training and 0.8% received some form of non-standard training which means 98.8% workers occupying skilled jobs did not receive any form of training.
- Distribution of employment pattern: - Professional-5.2%, Technicians- 1.8%, and Skilled Man-power-73% (98.8% untrained).

Workers employed in these skilled jobs without training contributes largely to low productivity and poor quality of products and services. Skilled workers are classified as NSS-Master-1.4%, NSS-I-8.2%, NSS-II-53%, NSS-III-27.4%, and Basic-10%, as in [2]. This shows most of the skilled worker towards lower skill side. All the programs and projects of Technical and Vocational Education of Bangladesh follow an integrated approach to Human Resource Development, as shown in Fig 1.

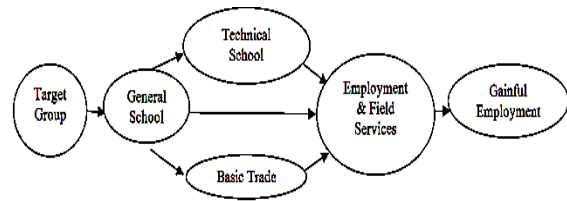

Figure 1. Integrated Approach to Human Resource Development in Bangladesh, as in [12].

### 2.1 Secondary School Certificate (Vocational)

The SSC (voc.) students are required to attend 1440 periods of instructions and 8-week industrial attachment. Brief course structure is given in table 1.

Table 1. Course Structure of SSC (voc.), as in [3].

Class	General Subject Period	Trade Subject Period	Total	Industrial Attachment
CLASS - IX	576	864	1440	8 Week
CLASS - X	684	756	1440	8 Week

There are two board final examinations, one in Class-IX and other in Class-X. Student assessment is done on the basis of board final examination and continuous assessment. However, course content of most of the general subjects and concerned text books are adopted from National Curriculum and Textbook Board, Bangladesh (NCTB) without sacrificing the special characteristics of SSC (voc.) curriculum, special examination system, special certification system {Three certificates, NSS-I, NSS-II and SSC (voc.)} and assessment procedure.

### 2.2 Higher Secondary Certificate (Business Management)

This project (later become program) took place in tune with practical needs of the individuals and society at large. From 1995-96 separate stream of business education at Higher Secondary level named as HSC (BM) introduced under BTEB to meet the new roles and challenges of office management support services of different government, non – government, semi-government and private business organizations and industries. The program consists of five courses- Accounting, Banking, Computer Operation, Secretarial Science and Entrepreneurship. Under five-year project starting from year 2000, in some selected colleges this curriculum was introduced in first case. Requisite furniture, computers, and typing machines were supplied in each college form the project. Even physical facilities also constructed in some institution. Since the inception of HSC (BM) curriculum, it has been popular to the students and as well as to the guardians. The number of

institutions offering HSC (BM) course increases geometrically all over the country on self-finance basis. In 2004 the numbers of institutions become 954 with about 64,000-intake capacity which covers the whole country. And the project converted to program.

Table 2. Condition of Business Management Vocational institutions in Bangladesh, as in [3].

Division	Number of Institutions	Entry capacity
Dhaka	213	13,740
Chittagong	84	6,210
Rajshahi	433	29,970
Khulna	136	9,840
Barishal	69	5,760
Sylhet	19	1,200
	954	63,720

### 2.3 Basic Trades

All over Bangladesh the BTEB offers different types of BT courses with duration 3 to 4-year. Following are the courses with the number of institutes and their intake capacities.

Table 3. Courses in BT with the number of institutes and their intake capacities, as in [3].

Course Title	Number of Institutions	Intake Capacity
Diploma (Dip.) Technical Education	01	120
Dip. Vocational Education	01	80
Certificate Technical Education	01	120
Dip. Engineering	109	11894
Dip. Engineering Glass/Ceramic	01	80
Dip. Engineering printing	01	50
Dip. Engineering Survey	02	264
Dip. Textile Engineering	16	1210
Dip. Agriculture	52	6460
Dip. Forestry	01	50
Dip. Marine Engineering	01	22
Dip. Shipbuilding Engineering	01	22
Dip. Aircraft Maintenance Engineering		
Avionics	01	22
Aerospace	01	22
Dip. Commerce	07	616
HSC (Business Management)	955	53275
HSC (Voc.)	64	2875
SSC (Voc.)	1280	91765

Course Title	Number of Institutions	Intake Capacity
SSC (Voc.Textile)	30	1804
NSS Basic	83	4140
NSS Grade-II & III	06	660
Computer Training Program	302	15696
Health Technology & Services		
Dip.-in-Medical Ultrasound	04	88
Certificate-in-Medical Ultrasound	04	88
Dip.-in Para Medical Dip.-in-Medical	02	44
Marketing Management Certificate-in-	01	22
Integrated Acupuncture ultrasound	01	22
Certificate-in-Secretarial Science	01	22
Business Typing	01	22

### 3. Achievement of Vocational and Technical Education in Bangladesh

The Bangladesh Technical Education Board started functioning from 1958. The BTEB has introduced market oriented demand based curriculums in different levels (Trade, Certificate and Diploma) and different Technical Vocational Education and Training (TVET) sectors. BTEB successfully introduced some emerging technologies in Basic Trade (Dip.-in-Engineering) course, e.g.: Construction technology, Telecommunication technology, Environmental technology, Instrumentation process control technology, Mine survey and Mining technology, Medical equipment technology, Dip.-in-Aeronautical and Avionics is introduced, Curriculum for the Medical Technician. Huge expansion of BTEB affiliated institutes throughout the country especially in SSC (voc.); HSC (BM) 4 years Dip.-in-Agriculture was remarkable. The total number of successfully passed-out graduates of different level of curriculum under the Bangladesh Technical Education Board (1958-2004) was 412,824.

### 4. Hurdles towards the development of Technical and Vocational Education and Training in Bangladesh

Technical and Vocational Education and Training in Bangladesh suffers from two types of problems;

1. Economical and infrastructural and
2. Social and methodological.

As a developing country Bangladesh is still fighting with poverty. On the other hand, to meet Millennium Development Goal, most of the money

from national education budget drained towards General education. Expense for military education is also provided from national education budget. In this situation Vocational and Technical Education is suffering from financial scarcity which is more expensive than general education. The existing inadequate vocational education facilities provide very limited opportunities, as in [8]. As a result numbers of infrastructure, buildings, workshop et cetera are not up to the mark. And many institutions do not have modern tools and equipment. Lack of good Teacher, Instructor and Master Craftsman is another main problem. Nearly 45 per cent of the posts of teachers of government polytechnic institutes are vacant, as in [7].

Most of the outside of city institutions suffers from problem regarding lack of necessary Co-ordination, proper monitoring, and close relation with the job market. Technical and Vocational Education and Training system in Bangladesh slows to change, always staying behind as technology changes at a good pace in work place. Another problem is this form of education suffers from low social status and lack of proper image in society. There is a concept in the society that, this type of education is only for financially or intellectually handicapped students. In the classroom students observe rather than participate in activities related to training. Which is definitely a problem regarding methodology.

### 5. Ways to jump over the hurdles

Collaboration should be established between Technical and Vocational Education and Training centers and industry and the job market for continuous updating curriculum, equipment and facilities.

Use of new information and communication technologies is the only way to improve the efficiencies and the outreaches of the TVET system. Continual updating of the content of the TVET curriculum is must for incorporating and integrating technologies of the future. BTEB should promote contextual learning, entrepreneurship and life-long learning in TVET Courses. More emphasis should be given on preparing multi-skilled workforce and providing the job experience required for up gradation of human resources. Competency-based training should be introduced with current need based training and retrain ability should be promoted simultaneously. The curriculum of the vocational training program should be revised with the balance of both technical and non-technical competences.

All the empty teaching post should be filled up immediately with skilled teachers, instructor and master craftsman and to ensure quality of them salary should be raised. Vocational and technical education system should be more decentralized in order to maintain good monitoring and

coordination. Teachers should be trained properly and continuously and those trainings must include methodology of teaching.

Changing society's view is not possible over the night. In General education system up to class X there is a compulsory social science subject. Now-a-days non-formal adult education is a hot topic in Bangladesh. Idea about vocational and technical education can be put in those places to slowly solve the social problem regarding vocational and technical education. Media can be another good solution to this social problem, when they can raise social awareness quickly.

### 6. Conclusion:

In a changing world where definition of Human Resource is frequently changing, this literature shows some achievement and weaknesses of Vocational and Technical Education in Bangladesh while proposes a number of well-thought new efforts towards this Education to develop professional labor force efficiently. The writer concluded that more in depth research studies should be conducted in the broad aspects for the further improvement of Vocational and Technical Education in Bangladesh for a sustainable future.

### REFERENCES

- [1] Bangladesh Ministry of Education. (1997). *Bangladesh National Education Policy Planning Committee Report, 1997*. Dhaka, Bangladesh.
- [2] Bangladesh Technical Education Board. (2004). *The Guardian*, Dhaka, Bangladesh.
- [3] BTEB, Bangladesh Technical Education Board. (2006). Dhaka, Bangladesh.
- [4] BANBEIS, Bangladesh Bureau of Educational Information and Statistics, Ministry of Education (1988). *Technical education in Bangladesh (BANBEIS Publication No. 70)*. Dhaka, Bangladesh.
- [5] Colin, J. M. (2004). *Key Concepts for Understanding Curriculum (3rd ed.)*. London: RoutledgeFalmer.
- [6] Carnoy, M (1995). *Structural Adjustment and the Changing Face of Education*, International Labour Review, Vol 134, No 6
- [7] Khan, S (2010). *Improving the quality of technical education in Bangladesh*, [http://www.thefinancialexpress-bd.com/more.php?news\\_id=103856&date=2010-06-23](http://www.thefinancialexpress-bd.com/more.php?news_id=103856&date=2010-06-23)
- [8] MOPME, Ministry of Primary and Mass Education, Government of the People's Republic of Bangladesh. *Education for All: National Plan of Action II 2003 – 2015 (Fourth Draft)*. Dhaka, Bangladesh
- [9] Patwary, A. A. (2006). *Comparison Between the M.Ed. Curricula of Public and Private Universities of Bangladesh*. M.Ed. Thesis, Institute of Education and Research, University of Dhaka, Dhaka, Bangladesh. Unpublished.
- [10] United Nations Development Program (UNDP), (1999). *Human Development Report*. New York, USA.
- [11] United Nations Educational, Scientific and Cultural Organization (UNESCO). (2001). *Statistical yearbook*. Paris, France.

[12] Underprivileged Children's Educational Programs (UCEP),  
(2005), Annual Report, Dhaka, Bangladesh

[13] World Bank, (2002). *Economic Growth and Public Policy:  
The East Asian miracle*. Washington DC, USA.

## CONTRIBUTION OF MECHANICAL APTITUDE, INTRINSIC MOTIVATION, AND CAREER GUIDANCE TO THE STUDY RESULTS OF LIGHT VEHICLE TECHNICAL SKILLS COMPETENCY

Mukhidin<sup>1</sup>, Heri Susanto<sup>2</sup>

<sup>1</sup>mukhidin2010@yahoo.co.id

### Abstract

This research is aimed to analyze and interpret the contribution of mechanical aptitude has been achieved by the students, the contribution of intrinsic motivation, the role of career guidance services to study results the Light Vehicle Technical Skills Competency in SMK Negeri 1 Sukabumi. The formulation of problems in this research is how much the contribution of mechanical aptitude, intrinsic motivation, and career guidance on learning process to the study results of the Light Vehicle Technical Skills Competency in SMK Negeri 1 Sukabumi.

The research method has been used in this research is research explanatory with using statistics testing. Data collection has been used is a test, questionnaire techniques, and documentation. Test techniques has been used to collect data variable X1, questionnaire techniques has been used to collect data variables X2 and X3, and documentation techniques to collect data variable Y. The results of reliability test with using Alpha formulation has been got the reliability coefficient for variable X1 is 0.888 with a very high category, the reliability coefficient for variable X2 is 0.945 with a very high category, the reliability coefficient for the variable X3 is 0.780 with a higher category.

Based on the testing results of Bartlett homogeneity it can be concluded that data variable X1 is homogeneous at the significance level of 0.990, variable X2 is homogeneous at the significance level of 1.050, variable X3 is homogeneous at the significance level of 0.921, and variable Y is homogeneous at the significance level of 0.776. With the frequency distribution normality test, data can be concluded that the data variable X1 normally distributed, at the significance level of 0.068, data variable X2 normally distributed at significance level of 0.057, data variable X3 normally distributed at significance level 0.093, and data variable Y normally distributed at significance level of 0.062. So the statistical test has been used was using parametric analysis with using three-predictor multiple correlation.

With using regression analysis has been got the regression equation  $Y = 50.597 + 0.152 X1 + 0.156 X2 + 1.621 X3$  so the relationship between the variables X1, X2, X3 with variable Y is in the same direction. With using F-Test can be concluded that there is a linear bond between the variables X1, X2, X3 and variable Y. The results of correlation calculation (RYX1X2X3) obtained at 0.539, so the correlation coefficient has been included into the category enough. Based on the testing results of determination coefficient has been got the price for 29.05%. It means that the contribution of mechanical aptitude, intrinsic motivation, and guidance of his career to learning achievement of students the Light Vehicle Technical Skills Competency for 29.05%.

The results of hypothesis testing has shown that the hypothesis of the research, is "there is a positive and significant contribution of mechanical aptitude, intrinsic motivation, and career guidance to learning outcomes the Light Vehicle Technical Skills Competency in SMK Negeri 1 Sukabumi has been accepted at the 5% in significance level.

From the research can be concluded that this research is successfully revealed the contribution of mechanical aptitude, intrinsic motivation, and guidance to study results of students in Light Vehicle Technical Skills Competency on SMK Negeri 1 Sukabumi.

**Keywords:** Mechanical Aptitude, Intrinsic Motivation, Career Guidance, Study Results of Student

---

### 1. The Problem Background

One of education institution which partake play role and responsible in delivering potential human resource is Vocational High School (SMK). Vocational High School according to section of PP No 19 Year 2005 about Standard of National Education " Vocational Middle Education is Education at level of vocational middle education

majoring development of student ability for type of certain work".

Therefore Vocational High School (SMK) claimed to delivering graduate have competence in the field of special skill. One of important factor influencing success of education process in SMK is student . To support process and success of study, hence the student require to be selected beforehand.

Aptitude very big contribution and have very high correlation to study result of student . Therefore data about special aptitude of vital importance for student to continue to SMK of industrial and technological group. Because at this institute, mechanic special aptitude of very support to success of student study.

Besides mechanic special aptitude, other factor which not less important in support to success of student is motivation. Motivation divide into two part, that is intrinsic motivation and extrinsic motivation. Extrinsic motivation can coming from teacher, environmental condition of school, environmental of residence, friend, or parent. While intrinsic motivation is motivation incoming from within student . Intrinsic motivation begin from existence anxiety of student at one particular items, then arise feeling to be like, believe in matter be like (can guarantee for future life), so that in the end will make it the requirement.

In order to mechanic aptitude and intrinsic motivation can support to success of student hence needed one effort of construction for trace and instruct of mechanic aptitude and intrinsic motivation of student. The effort can be done through service of career tuition. Hence from that role of career tuition at school have very important role.

SMK Negeri 1 Kota Sukabumi, one of vocational high school carrying out Program of Light Vehicle Technique Skill and represent to Pioneer SMK International Level . Investigation of mechanic aptitude and excavation of intrinsic motivation of student and service of Career Tuition represent a requirement which need to be executed for the shake of taking care of school quality.

## 2. Problems

Formula of Problem will be research as followings :

- 2.1 How big contribution of mechanic aptitude to study result of Light Vehicle Technique Skill Competence in SMK Negeri 1 Kota Sukabumi.?
- 2.2 How big contribution of intrinsic motivation in study process to study result of Light Vehicle Technique Skill Competence in SMK Negeri 1 Kota Sukabumi ?
- 2.3 How big contribution of career tuition to study result of Light Vehicle Technique Skill Competence in SMK Negeri 1 Kota Sukabumi ?
- 2.4 How big contribution of mechanic aptitude, intrinsic motivation, and career tuition in study process to study result of Light Vehicle Technique Skill Competence in SMK Negeri 1 Kota Sukabumi ?

## 3. The Target of Research

The formula target of research shall be as followings

To analyses and interpretation contribution of mechanic aptitude which owned by student to study result of Light Vehicle Technique Skill Competence in SMK Negeri 1 Kota Sukabumi

To analyses, and interpret contribution of intrinsic motivation in learn process to learn result of student at Light Vehicle Technique Skill Competence

To analyses the role of service of career tuition in tracing mechanic aptitude and intrinsic motivation to all student .

To expression Intrinsic motivation to learn result of Light Vehicle Technique Skill Competence in SMK Negeri 1 Kota Sukabumi.

## 4. The Research Benefit

This research result expected can give usefulness and benefit meaning, that is

- 4.1 As input material for decision maker in problem of student acceptance selection to specify policy to be taken, specially at Light Vehicle Technique Skill Program
- 4.2 As input material for teacher of BP/BK in giving service and counseling of career tuition to student .
- 4.3 As input material for teacher of Light Vehicle Technique Skill Program in giving study service to student , as according to student characteristic
- 4.4 As input material for teacher of Light Vehicle Technique Skill Program in order to can grow intrinsic motivation of student in following study process.
- 4.5 As comparison or consideration for the research furthermore..

## 5. Foundation of Theory

### 5.1 View of Aptitude

Aptitude can be interpreted as characteristic combination which viewed as a somebody ability symptom to get knowledge, skill, and let ripen through some practice. Basically nd everybody have certain enthusiasm and aptitude, therefore need one measurement to know existing enthusiasm and aptitude in every individual. Aptitude test done to know how far aspects of ability, strong and weakness among aspect which is one compared to a other aspect.

Several things which can be formulated concerning aptitude, for example :

- 5.1.1 Aptitude represent one of potential proficiency in certain sectors, what is with practice will become actual proficiency.
- 5.1.2 Aptitude represent result of interaction between clan factor (*hereditas*) and environmental factor.
- 5.1.3 Aptitude represent the part from character individual, so that no two or more same individual precisely in its aptitude strength
- 5.1.4 In every individual there are all kinds of different aptitude also its strength.

Aptitude or special ability as potency which owned by student individual very important to be dug in order to appear and can application correctly as according to its sector. This matter is important to know individual ability weakness and strength of student, in order to the student able to comprehend itself so that the student will be able to make career decision and planning in the future.

Aptitude aspect measured pursuant to Differential Aptitude Test = DAT are (1) Verbal Reasoning (VR), (2) Numerical Ability (NA), (3) Abstract Reasoning (AR), (4) Space Relations (SR), (5) Mechanical Reasoning (MR), (6) Clerical Speed and Accuracy (CSA), (7) Language Usage : Spelling And Grammar .

Combination from score Verbal Reasoning and Numerical Ability will somebody skolastik ability, and represent a estimation which good about skolastik aptitude, that is a ability to finish preparation study program for enter college at school, and success in college.

To know special aptitude of somebody in the mechanics field, can be done with two ways, that is through mechanic reasoning test and Physic Ability test. Mechanic reasoning test in general used to express somebody ability in catching or comprehending common principles of physics as base work of appliances and machines and also the simple movement. Physic Ability test in general used to express somebody ability in the physical, including: strength, agility, skill, ability solve problem in field.

Aptitude measurement is good for assisting student in comprehending itself precisely, clearly, real correct, and logical. Especially which is concerning ability, potential specially, and characteristic of its personality. In order to the student can chosen correct action, both in study action, chosen to program or majors, chosen to education furthermore, chosen to friend and etcetera.

## 6. View of Motivation

Aptitude not representing one factor determining study result of somebody. Aptitude also very influenced by other factor which represent

a group. Aptitude also very influenced by other factor representing a group of nature forming aptitude. Aptitude will not increasing or developing with themselves is one without along with intrinsic motivation.

Study achievement a student which is one sometimes differ (more good /more bad) with other student , though the conditions created for two student of equal. This matter non because of student disability, but more amount because different each other it the motivation have owned by the student , student which strong motivation (good) hence the study achievement tend to good or gratify and conversely, if low motivation hence study achievement of low also.

Somebody conduct a certain action is intrinsically relied on a requirement which must be fulfilled and gratified. The requirement arising from felt a insufficiency existence experienced by somebody periodically. Soul symptom at somebody itself which forming of desire or motivation to conduct a action or deed be called by motivation.

Oemar Hamalik (2009:158) expressing Motivation is change energy in somebody personality marked with appear of feeling and reaction to reaching purpose. Then be formulate three content element which each other be interconnected as the following :

- 6.1 Motivate started from existence of change energy in personality. Changes in motivation arise from certain changes in neurofisiologis system in human being organism. For example existence of change in digestion system will generate hungry motif. However, there are also change of energy unknown
- 6.2 Motivate marked with arise of feeling. The beginning represent psychological stress, then atmosphere of this emotion arise motif behavior. This change may be awareness, may be not. We can observation to deed.
- 6.3 Motivate marked by reactions to reach purpose. Personality have motivation perform response which gone to toward purpose. That Responses function to decrease stress cause by change of energy in itself. Every response represent a step to reaching of purpose.

In study activity, study motivation interpreted as entirety of psychical locomotion in itself of student generating learn activity, guarantying the continuity of learn activity, guarantying the continuity of learn activity, and give instruct at lear activity that for the shake of reaching of purpose.

Motivate have two components, namely inner component and outer component. Inner component is change in somebody itself, circumstance dissatisfy, psychological stress. Outer component what wanted by a somebody, target becoming

direction of its activity. Human being will ready to improve its productivity if there are confidence in itself that various target, expectation, desire, need, and its requirement will be reached.

Lear activity represent activity needing existence motivation. According to Sadirman A.M. (1994:84), that " Motivation Is an essential condition of learning". Result of learn will be

optimal, if there are motivation. More and more precisely the given motivation, will more and more to succeed also that Lesson. Become motivation will ever determine intensity of effort learning the student .

By schematic process occurring of motivation described as following:

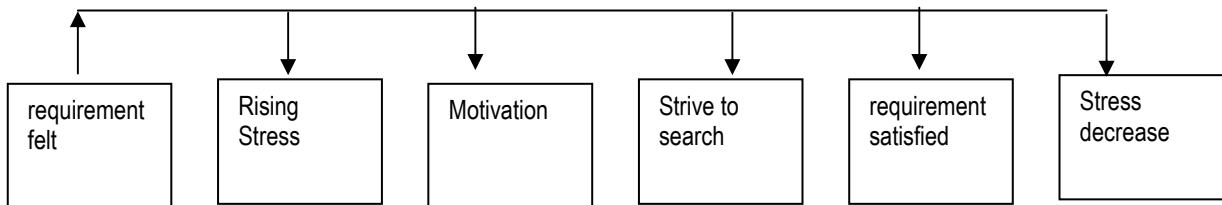

Figure 1. Process occurring of motivation

Above schema show the followings:

- 6.1 In human life always arise requirement and which need to satisfied it
- 6.2 That requirement can only be categorized as requirement if stress in itself of pertinent prang, more and more critical of requirement nature more and more high also the stress which resulting of
- 6.3 Stress that's generating pertinent motivation in order to " doing something"
- 6.4 "Something" that is effort look for way out in order to the stress faced not continue.
- 6.5 If effort look for "way out" what taken succeed, meaning requirement have satisfies
- 6.6 Satisfies success requirement will degrade stress, however not eliminate is at all. Reason that same requirement slowly or quickly will arise then, possible in the form of newly and possible also with different intensity, that's such with no there are "saturation point" in satisfied requirement human being.

Activity impelled by intrinsic motivation generally outwear compared to a activity impelled by extrinsic motivation. Therefore be better this intrinsic motivation which grown in somebody itself to every its activity. Student which learn pursuant to intrinsic motivation of learning spirit very strong not because of wishing to get high value, expecting praise or have prize but because wishing to get science as much as possible.

Motivation measurement done by seeing some indicator in the form of pertinent individual behavior. According to Syamsu Yusuf (2008 : 163) having a notion that to know motivation strength in individual itself can be done by identification some indicator, that is :

- 6.1 Its activity Duration (How long use its time ability to do activity)
- 6.2 Its Activity frequency ( often not it that activity done in certain time period
- 6.3 Persistence ( its viscosity Or Decision) at activity target which done
- 6.4 Devotion and sacrifice ( Money, energy, mind, even its soul) to reach target.
- 6.5 Manful, resilient, and its willingness in face of difficulty to reach target
- 6.6 Aspiration level (intend its] goal and plan) what will be reached with done activity
- 6.7 Qualification level from achievement, product or output be reach from activity (how many adequate or not, gratifying or not
- 6.8 Instruct its attitude to its activity target (like or dislike, negative or positive)

## 7. View of Career Tuition

According To Rochman Natawidjaja (Syamsu Yusuf 2008 6) interpreting that :

Tuition is a process giving assistance to individual done chronically, so that the individual get understand itself, so that he/she ready to instruct itself and can act to the manner born, as according to environmental circumstance and demand of school, family, socialize and life generally. Thereby he/she will enjoy its life bliss, and can give contribution meaning to life socialize generally. Tuition assist individual reach itself growth in an optimal fashion as social creature.

In all education activity specially at arrangement every school, and counseling tuition service have strategic and very important role and position. Counseling and tuition the role to give



service to student in order to can expand in an optimal development through effectively study process. Target counseling and tuition according to guidance-book of tuition and counseling at middle school (2008 3) that is :

- 7.1 Assisting student comprehend, accepting, instructing and developing enthusiasm, aptitude, and its ability as optimal as possible
- 7.2 Assisting student adapt to environmental circumstance of family, society and school
- 7.3 Assisting student planning life in the future matching with the demand at the moment and also at the time in coming.

To assist student in order to reach optimal growth in learning process according to Mohamad Surya (2008 : 14) there are four type of service of tuition of counseling to reach expected target, that is

- 7.1 Personality tuition to reach competence: (a) monitoring of attitude and habits of moral ( b) the understanding of strength and itself (c) strive development and identification of strength and weakness itself, ( d) the understanding of aptitude and weakness itself, (e) the understanding of healthy life
- 7.2 Social tuition, to reach competence: (a) understanding and deed of discipline and school regulation, (b) development of harmonious relation with peer friend, (c) development of harmonious relation with family, (d) development of social relation with respect value and norm of religion, custom and law, (e) development of ability communicate verbally and writing, (f) development of ability solving conflict
- 7.3 Learn tuition to reach competence: (a) development of attitude and habit of good learn, (b) growing learn discipline by ways alone and team, (c) developing domination of lesson items for attainment of learn target, (d) exploiting of school environmental condition to develop knowledge, skill and personality, (e) Learn orientation in level of education furthermore.
- 7.4 Career tuition to reach competence: ( a) the understanding of education information, (b) work world Identification, (c) orientation and information of occupation and effort, (d) Self concept identification relation with aptitude and tendency of choice of occupation and also instruct career development

According To National Vocational Guidance Association (Dewa Ketut Sukardi 1989 : 22): Career tuition is service aid which give to individual for choice, preparing, adaptation and

specifying itself in appropriate work and also bliss from its.

Pursuant to opinion all expert from service result of career tuition expected to can be in the form of: (1) workable skilled, adaptation, increasing work and academic, (2) productive work habit, (3) personality work values having a meaning, (4) understanding and basic appreciation to businessman, (5) self comprehension and education opportunity and work available (6) decision making of career, (7) searching, finding, getting and holding of work, (8) leeway use productively, (9) lessening deviation and esteem full freedom of career choice for everyone, (10) humanism workplace for oneself.

## 8. View of Learn

Interpretation of learn emerge with various definition which different each other. Slameto (2003:2) saying that interpretation of learn is:

Learn to represent change process that is behavior change as result of interaction with its environmental in fulfilling requirement of its life and the learn is effort process done a somebody to get a whole newly behavior change, as result of self experience in interaction with its environmental.

Wherington (Ngalim, 2004 : 84) saying that 'learn is personality change expressing itself as a new pattern from reaction which in the form of skill, attitude, habit, cleverness or a interpretation'.

Furthermore Slameto (2003 3) saying characteristic of behavior change in interpretation learn as following:

- 8.1 Change happened consciously
- 8.2 Change in learn to have the character of continue and functional
- 8.3 Change in learn to have the character of active and positive
- 8.4 Change in learn non tentative
- 8.5 Change in learn have purpose and directional
- 8.6 Change include all aspect of behavioral.

By learn that human being will get something a newly and affect to behavior having the character of permanent. In relevancy learn with student be expected they get something knowledge or skill a newly as manifestation of behavior change. Result learn not only affect at aspect of behavior as a whole.

Result learn to represent ability or skill have owned student after through experience from learning process which gone through. Ability here include ability having the character of cognitive, psychomotor and also affective. Learn result to represent indicator of quality and quantity of

knowledge which have been mastered by the student at the school.

Taxonomy of learn according to Bloom, Kratwohl and Anita Harrow as following :

**8.1 Type of learn result of cognitive, consisted of**

- 8.1.1 Knowledge, including memory ability about things which have been learned and on file in memory. The knowledge can reference with fact, event, interpretation, theorem, theory, principal or method
- 8.1.2 Understanding, including ability catch essence and meaning things which learning.
- 8.1.3 Applying, including ability apply method, theorem, to face problem really and newly
- 8.1.4 Analysis, including ability detail an union into parts so that all structure can be better known
- 8.1.5 Synthesis, including ability form new pattern
- 8.1.6 Evaluation, including ability forming opinion about several things pursuant to certain criterion
- 8.1.7 b. Type [of] result of learning afektif, consisted of
- 8.1.8 Acceptance, including sensitivity to certain matter and the readiness pay attention to the matter mentioned
- 8.1.9 Participation, including blessing, readiness pay attention to and participate in a activity
- 8.1.10 Assessment and determination of attitude, including acceptance to a value, esteeming, confessing and determining of attitude
- 8.1.11 Organizational, including ability forming a assess system as guidance and hold of live
- 8.1.12 forming of life Pattern, including ability comprehend fully of assess and it forming become personal life assess pattern.

**8.2 Type [of] result of learning afektif, consisted of**

- 8.2.1 Perception, including ability to sorting (description) something peculiarly and realize existence of difference among that something.
- 8.2.2 Readiness of, including ability place itself in a circumstance where will be happened one movement or movement series, this ability include corporeal spiritual and physical activity.

8.2.3 Guide movement, including ability do movement according to example or imitation movement

8.2.4 Accustomed movement, including ability do movement without example

8.2.5 Complex movement, including ability do movement or skill consisted of a lot of phase by fluency, efficient and precisely

8.2.6 Adjustment of movement Pattern, including ability perform change and adjustment of movement pattern with special conditions going into effect

8.2.7 Creativities including ability think out movement pattern a newly on the basis of initiative by itself.

From inferential above description that learn achievement is learn result of individual in the form of behavior change for concerning knowledge, attitude and skill which obtaining of during following learning activity in certain range of time measured and poured in the form of value obtained through evaluation to learning teaching process. Go together this research evaluation result of learning practice of Light Vehicle Technique Skill Competence.

Evaluation of learn result is determination assess result of measurement with certain standard or reference. Evaluation of learn result the student represent integral part from learning process, to assess performance of student (monitoring process, progress and repair of learn result) chronically. Evaluation of learn result aim to

8.2.1 Knowing how far have been happened by advancement of learn result at itself of student , as consideration in specifying learn tuition furthermore.

8.2.2 Knowing success level of student , as consideration in specifying whether pertinent succeed (passed) or not (not yet) succeed in going through a learning program.

8.2.3 Specifying master level of student to competence of certain skill matching with in qualify competence standard.

Implementation of evaluation can be done directly at the time of student do activities of learn, and also indirectly through evidence of learn result as according to performance criteria. Evaluation system of curriculum SMK 2004 focused at competency based assessment.

To get confession to competence which have been mastered by student hence one of its way done a verification. Verification to assessment result of internal party of SMK by external party, in order to what have been reached by the student can

certification by work world using graduate, that is corporate world and industrial world.

## 9. The Research Method

The purpose of this Research is to know image about mechanic aptitude, intrinsic motivation, service of career tuition contribution to learn result of light vehicle technique skill competence in SMK Negeri 1 Kota Sukabumi. Therefore research method using in this research is explanatory survey.

In this research is first independent variable is mechanic aptitude of student ( $X_1$ ), as second independent variable is intrinsic motivation of student ( $X_2$ ) and as third independent variable is service of career tuition ( $X_3$ ). As dependent variable is learn result of light vehicle technique skill competence ( $Y$ ).

As for technique of collecting data (instrument) used in this research [is]: (1) Test, that is mechanic aptitude test which aim to measure how big mechanic aptitude have owned by student, data obtained at this mechanic aptitude test used for processing of variable  $X_1$ , (2) Questioners. This questioner is the first, used to know how big the intrinsic motivation of student in following learning of light vehicle technique skill competence, data obtained to be used for processing of variable  $X_2$ , and the second, used to know how big service of career tuition assist student in reaching learn result of light vehicle technique skill competence, data obtained to be used to get variable  $X_3$ , (3) Documentation. Data in this research, that is learn result assessment of light vehicle technique skill competence of student of school year 2009/2010. Data obtained to be used for processing of variable  $Y$ .

## 10. Research Result

Based on obtained data analysis, can pulled conclusion from above research problems. From collected data and analysis result as which have been decanted in previous section in outline the research reply question formulated in research target. Hence from that can be taken decision, as following :

10.1 Contribution of mechanic aptitude, intrinsic motivation, and career tuition to learn result of

light vehicle technique skill competence inclusive of into enough category, by price of correlation coefficient ( $R_{y \cdot x_1 x_2 x_3}$ ) = 0,539. If interpreted marginally meaning mechanic aptitude contribution, intrinsic motivation, and career tuition to learn result of light vehicle technique skill competence show positive direction, this where this matter is shown at the price of regression equation

$$10.2 Y = 50,597 + 0,152 X_1 + 0,156 X_2 + 1,621 X_3$$

10.3 so that known correlation among variable  $X_1$ ,  $X_2$ ,  $X_3$  and Variable  $Y$  unidirectional

10.4 Image without learn result learn of student in SMKN 1 Sukabumi for the vehicle technique competence i] 21 participant inclusive of good passed category, 17 participant inclusive of very good passed, and 9 participant inclusive of special passed category according to qualification standard of assess in SMKN 1 Sukabumi. Average value of daily Examination of student at light vehicle technique skill competence, that is 75,68.

10.5 There are relation which are positive and significant, that is equal to 29,03%, its meaning is effective contribution given by mechanic aptitude, intrinsic motivation, and career tuition to learn result of student equal to 29,03% for the light vehicle technique skill competence in class 11 SMKN 1 Sukabumi inclusive in logical category, because in order to the student can succeed in learn process needed mechanic aptitude, intrinsic motivation, and career tuition service

10.6 By known is price  $F_{count}$  equal to 9,271 hence  $H_0$  refused. The meaning is hypothesis proven, that is there are contribution positive and significant of mechanic aptitude, intrinsic motivation, and career tuition to learn result of student at light vehicle technique skill competence in class 11 SMKN 1 Sukabumi.

10.7 Seen from research target, hence the research about contribution of mechanic aptitude, intrinsic motivation, and career tuition service to result learn of student at light vehicle technique skill competence can be told to succeed.

# ENHANCING THE QUALITY OF LEARNING BASIC MATHEMATIC APPROACH FOR PROBLEM BASED LEARNING THROUGH CONSTRUCTIVISTIC AT THE DEPARTMENT OF HOME ECONOMIC

Neneng Siti Silfi Ambarwati, M.Si., Apt.

Lecturer in Health and Beauty Program, Jakarta State University  
neneng\_ambarwati@yahoo.co.id

## Abstract

Pursuant to research result, indicating That constructivistics throughs of applying the method of problem-based learning in management of the subject activity of Basic Mathematic have a positive impact to effectiveness storey; levels posed Attainment of lecturing at the target through growth of result learn the reality of the participant of lecturing . For Health and Beauty studies program, at the cycle of I, students average value of 66.9, the final average value of the cycle of II is 70.8 and average student value at the cycle of III is 77.2. While average values During treatment (3 cycles) instruction of Basic Mathematic is 71.63 meaning the value was higher before the Than All That is 60.8. Through this approach of instruction, more student besides also learn motivational level Mathematic student at the subject. Meanwhile for Fashion Design study program, at the cycle of I, students average value of 66.6, the final average value of the cycle of II is 79.16 and student average value at the cycle of III is 94.33. While average values During treatment (3 cycles) instruction of Basic Mathematic is 79.80 meaning the value was higher before the Than All That is 66.6. Through this approach of instruction, more students besides also learn motivational level Mathematic student at the subject and independent for studying this subject.

**Keywords:** enhancing, constructivistics, mathematic, problem, based, learning, motivational, home economic.

---

## 1. Introduction

The Basic Mathematic subjects is one of the compulsory subjects, which is a fairly difficult subject for students including those who take majoring in Home economic department. This is because of the mathematic concept and theory is abstrac and rigid . Besides advanced mathematic have not been studied continously at the department of Home economic except statistics. So the interest and motivation to learn Mathematic is minimum.

Home economic Students consists of Catering, Dressmaking and Makeup should take advantage of logical mathematic, because they have to deal with macro-economic classes, statistics, research methodology, basic physics, basic chemistry, the practice of cloth/clothing, and management. Based on the observation that the authors have a negative perception of students about the subjects of Mathematic. This course is considered a daunting for college students as well as lecture instructors always considered a "killer". Resulting in low spirit of students to attend lectures, because students always feels tense and insecure. It is characterized by an atmosphere of passive students when learning Mathematic in the classes: listen more than to respond to or discuss the material being taught lecturer. Classroom interactions between professors and students in the learning context is at its lowest, so there tends to be one-way

communication. This situation gets worse because the method of teaching Mathematic professor who conducted the lecture method by using the frequently asked questions, practice problems and homework as a way to increase students' skills in working on problems.

Therefore necessary to increase student interest and ways of teaching materials to suit the needs and knowledge level of students. Among others, by changing teaching methods (conventional) with the constructivist approach through Problem Based Learning method. Through a constructivist approach to student self-directed learning and thinking realistically to construct a concept that got its own, in hopes of better student retention. One way to train memory is to give students about cases or problems directly related to the interests of study or daily occurrence. This is done to further vary the teaching methods, in addition of course to improve and optimize the ability of lecturers in delivering course material, which is expected to help students to better absorb the material being taught, so that learning outcomes are achieved can be optimized.

## 2. Main Content

Based on expert opinions, conceptually Mathematic learning outcomes defined as change of behavior of cognitive ability obtained by students

after attending the lectures of Mathematic during the period of time. While operationally defined as the ability to learn the results obtained through achievement test that includes knowledge, comprehension, application, analysis, synthesis, on the facts, concepts, principles and operating procedures Mathematical theory.

Teaching and learning process is the combination of two activities, namely teaching and learning, they are inseparable and will form an interaction. Teaching and learning processes have components which exist in kurikulum. The components in question include the objectives, teaching materials, methods and tools, and assessment (evaluation). The four components are interrelated and influence each other. Therefore, the lecturers as executor of learning process is expected to make preparation for teaching and learning, implementing and evaluating learning outcomes.

In carrying out a good and right activities in teaching and learning , it takes the existence of a systematic preparation and adequate teaching. Through this preparation is expected to be predicted about what it is to be realized during the learning process. There are several components that need to be prepared in terms of determining teaching goals, determine the material (matter) a lesson, determine the teaching and learning activities (methods and strategies), determine the assessment of learning outcomes.

After making preparations to teach, then faculty activity is to realize what had been predetermined in the form of real activity during the learning process takes place. Actions lecturer in teaching this course will influence every step that make up the learning process. Sudjana (1989: 68) defines teaching as a step step step lecturer / teacher in implementing the learning process and how the lecturer / teacher in developing student learning activities, in connection with the material to be taught.

There are several steps that must be taken in implementing the teaching faculty, namely: the beginning stage, the stage of teaching and assessment and follow-up phase (Sudjana; 1989; 108). Beginning stage is the stage which aims to set conditions for learning that can facilitate students receive lessons. At this stage there should be a pretest. This is done to determine the abilities possessed by students, as prescribed in teaching purposes. By looking at the results of the pretest, faculty can determine the material that may no longer be served.

Stages of teaching is the core stage, the stage of adding material that had been prepared previously. At this stage must always adhere to the preparation of teaching that had been prepared. The activities at this stage will be influenced by the type of teaching approach used by lecturers / teachers.

Hence the need for skill mix all forms of the supporting element for the successful implementation of teaching.

Evaluation of the teaching process conducted by the professor as an integral part of teaching itself, meaning that the evaluation should be an integral part of the preparation and implementation of teaching. The evaluation aims to assess the effectiveness and efficiency of teaching as a material for the development and improvement of preparation and implementation of teaching.

In essence the result of learning is influenced by various psychological aspects, attention, namely concentration of psychic energy is focused on an object, the consciousness that accompanies an activity being carried out, observations, namely how to recognize objects by sight, hearing, smelling, tasting, touching (the five senses ), either himself or about where he is, response, namely a picture that lives in memory of someone once observed, so the effect on subsequent individual behavior, memory, namely the influence of processes taking place in the past in some way be reinstated in the present.

Therefore Mathematic curriculum should include three elements: concepts, skills, and problem-solving. The concept shows the basic understanding, skill refers to something done by a person and tend to grow and can be enhanced through training and problem solving is dari application of concepts and skills.

Constructivist learning is a process attaches new information on relevant concepts contained in a person's cognitive structure to establish and develop students' ability in mastering the course material (Dahar, 1995). So, the learning process not just memorize the concepts or mere facts (root learning), but trying to link these concepts to produce a full understanding (meaningfull learning), so the concept is learned will be well understood and not easily forgotten.

In the constructivist view, freedom of initiative is seen as a critical success because of the control initiative is seen as a determinant of success. Application of constructive learning in the learning process is expected Basic Mathematic: information learned will be longer remembered, the information lead to increased differentiation of thinking, thus facilitating the learning process next to a similar material, and although the information already been delivered not be called again by the memory or there have been forgotten due to obliterative thinking (subsumsi damaged), but still leave residual effects in subsumer, making it easier to learn things like the next (Novak & Gowin, 1977 in Sholahuddin, 2000).

One way is through a constructivist approach to learning Problem Based Learning method. Problem Based Learning By Tjipto and Ruijter (1994:84-86) is called a systematic problem-

solving. Lawrence Senesh (1996) in Saptono (2003), suggests there are three stages in the process of solving mathematical problems, namely: motivation phase, the development stage, and culmination stages. Teaching problem solving itself is in the second phase is under development with completion of these steps as follows: symptom of the problem, aspects of the problem, definition of the problem, and scope of the problem. Problem based learning methods can be stated that students will actively participate and will also be actively thinking and reasoning develops.

Given the number of students attending Basic Mathematic pretty much, in order to obtain optimal results then formed groups to study and analyze the results about the problem based learning was presented in front of the class or group of mahasiswa which usually are small, organized (classified) for the sake of learning (Roestiyah 1991).

Another definition of group work is presented by Muhammad Nur and Retno Wikandari in his book *To the Student-Centered Teaching and Constructivist Approaches in Teaching* (2000: 25), which states that the Cooperative Learning (Cooperatif Learning) is a teaching method where students work in groups with mixed abilities. Here the students are divided into small groups, usually between three to five people and groups that will continue for several weeks or months. One method of cooperative learning according to Slavin (1994) who quoted Mohammed Nur & Wikandari is the method of Student Teams Achievement Divisions (STAD) or Student Team, Group Achievement. Learning method is very suitable to teach learning objectives that are formulated with a sharp single correct answer, as characterized by mathematical calculation and application, the use of language and mechanics, geography and map reading skills and the fact science facts and concepts. The aim of the working group is to motivate students toward activities related to existing problems and to work together in groups of data and information materials will be collected to solve more problems in no time.

Presentation is one form of teaching methods with simulation. Simulation is the behavior of a person to act like someone who intended to aim for that person to learn some more about how people feel and do something. Merger group work and presentation methods are used to further create better results. Results of the working group then presented by the group to share the information obtained to classmates, with the aim to provide experience to students to be more familiar with leadership and experience to communicate something in front of an audience problem. In Mathematical Economics course, group work is useful for sharing knowledge and ability to read and understand a story about the application of mathematical theory in economics and business. So

the faster students understand about the story given faculty can explain to friends sekelompoknya, for members of the group can also understand the matter in question. In this group work, teachers act as facilitators who guide and provide various types and kinds of problem-solving story as well as the correct way.

Constructivist thinking recognizes that learning is something that is complex and multidimensional that goes far beyond the various methodologies that only exercise-oriented and stimulus / response (stimulus-response). Modern learning suggest that learning occurs only when students process new information or knowledge in such a way that felt reasonable in accordance with the framework of thinking that has (memories, experiences, and responses). Naturally, when there is new knowledge, one's mind to work to find the meaning of new knowledge in a real context, and can only occur through unreasonable searches and links useful. Subject matter mix with the everyday context students will produce the basics in-depth knowledge in which students are rich in understanding the problem and how to solve them. Students are able to independently use the knowledge to solve new problems and have never encountered, and have more responsibility to learn along with increased experience and knowledge.

Constructivist learning should have eight major components of making meaningful connections, doing significant work, self-regulated learning, collaborating, critical and creative thinking, nurturing the individual, reaching high standards, and using authentic assessment. Conceptually, the quality of learning is not different from the meaning of the effectiveness of the PBM, when viewed from the indicator evaluations. Sudjana (1990) uses a number of indicators to assess PBM, such as the quality of learning, skills, teaching skills, student activity, motivation and so forth. Researchers argue that the quality of learning can be viewed in terms of utilization of time in class (time of learning and time of the task), and active participation of students, changes in behavior and attitude to learn, and learning outcomes. In a constructivist approach to learning with the pressure there is on student activity.

The student must be considered is contained in the Mathematic curriculum manuals UNJ academic lectures and events Mathematic unit basis. Students are also equipped with the knowledge of Mathematic and learning materials.

To monitor the use of various instruments such as a diary that made the students, lecturers, questionnaires, interviews, observation and documents. As for the tests used to measure learning outcomes are open to both a group or an individual. Data being collected includes quantitative and qualitative data.

Therefore, the analysis carried out quantitatively and qualitatively as a reference reflection. Where the results of reflection is used to make improvements plan the next cycle. In summary brief step-reflection analysis as follows: Analysis – Understanding - Explanation - Conclusion - Identification of follow-up. If the 1 cycle is not satisfactory, then the initial plan is repaired or modified where necessary.

Learning achievement of students after attending the course Basic Mathematic which is the compulsory subjects, showing significant progress by using the approach of learning through Problem Based Learning constructivist. This development is shown from the results of reflection on the first cycle, second and third. The Basic Mathematic course material is designed as an application concept of learning Mathematic. This course is a basic science that supports student's understanding of other college students and help control the field of expertise Catering, Makeup and dressmaking. The approach of Mathematic learning through the completion of the case can be made by the students through the four stages of learning, namely: identifying problems, developing mathematical modeling, calculating data and selecting the appropriate option.

This is evidenced by an increase in student learning achievement Makeup Course starting from the first cycle the average value of 66.9, the average value of 70.8 cycles II and III is 77.2 cycles with an average increase of 5 changes, 15 points .. While student learning outcomes for each cycle Dressmaking Studies Program is the first cycle, 66.6 math scores, the average value of cycle II was 78.16 and the average score of students in cycle III is 94.33. While the average value during treatment (3 cycles) Basic Mathematic teaching is 79.80 which means higher than the previous value of 66.6. Through this teaching approach, in addition to more independent students also increased students' learning motivation in the field of Mathematic.

Observation of students through observation Mathematical problems in everyday life, providing a very positive contribution in improving student understanding of conceptual abstract. Students get real experience through the matter of the case. Formation of group discussions and class discussions by students with enough critical situations to discuss the problems of Mathematic. In addition, these activities can increase confidence and facilitate the students make decisions rationally. Making consolidated results of group discussions and exercises work on the problems that varied add their insights about learning and teaching Mathematic.

Reflection sessions that evaluate student learning outcomes on the quality of constructivist learning, identify problems, create a model or hypothesis of the concept of problem solving

through the mastery of Mathematic, giving encouragement and motivation to students to be more active and collaborative discussions Mathematical concepts gradually. This has an impact on students' memory in terms of resolving problems in a systematic and gradual plan.

Results of a questionnaire distributed to students at the end of the cycle indicate a positive assessment of Mathematic learning.

- (A) The Basic Math clear learning objectives.
- (B) The contents of the material provided is easy to follow
- (C) How to present the material more attractive students
- (D) Exercise matter more varied, but felt increasingly difficult to resolve, because the mathematical variables entered in cases that must be identified by the student.
- (E) The time provided for basic college Mathematic inadequate.

### 3. Conclusion

Learning achievement of students after attending the course Basic Mathematic which is the compulsory subjects, showing significant progress by using the approach of learning through Problem Based Learning constructivist. This is evidenced by an increase in student learning achievement Makeup Course starting from the first cycle, cycle II, and III cycles. Through this teaching approach, in addition to more independent students also increased students' learning motivation in the field of Mathematic.

Observation of students through observation Mathematical problems in everyday life, providing a very positive contribution in improving student understanding of conceptual abstract. Students get real experience through the matter of the case. Formation of group discussions and class discussions by students with enough critical situations to discuss the problems of Mathematic. In addition, these activities can increase confidence and facilitate the students make decisions rationally. Making consolidated results of group discussions and exercises work on the problems that varied add their insights about learning and teaching Mathematic.

Reflection sessions that evaluate student learning outcomes on the quality of constructivist learning, identify problems, create a model or hypothesis of the concept of problem solving through the mastery of Mathematic, giving encouragement and motivation to students to be more active and collaborative discussions Mathematical concepts gradually. This has an impact on students' memory in terms of resolving problems in a systematic and gradual plan.

## REFERENCES

- [1] Ahmad, Abu, 1999, "Psychology of Learning", London: Rineka Copyright.
- [2] Arifin, Mulyati, 2000, "Strategy Teaching Nelajar Natural Knowledge", London: UPI Science.
- [3] Ariyoto, Krenohadi, 1977," Problem Based Learning "(Problem-Based Learning)", Entrepreneurship Magazine no. 5 Th XXVI May
- [4]Black, James A and Dean J. Champion., 1992 "Research Methods and Problems Social", Bandung: PT.Eresco.
- [5] Bogdan, Joseph, et.al., 1990, "Qualitative Research for Education Introduction to the Theory and Method, translation by Munandir", New York: Publisher: MOEC.
- [6]Bueche, Frederick J., Schaum's Book Series. 1994," Theory and Problems of Mathematic", London: publisher.
- [7] Degeng I Nyoman Sudana, 1999,"Learning Konstruktivik: Goals, Strategies and Evaluation, Learning Methodology Training Papers Constructivist", Malang August 23 to 28.
- [8] Dumairy, 2003,"Being of Mathematic for Business and Economics", London: BPFE.
- [9]Eliot, J., 1996,"Action Research for Educational Change", Philadelphia: OpenUniversity Press.
- [10] Giancoli., 1993,"Mathematic", Jakarta: PT Gramedia.
- [11] Gulo, W., 2002,"Teaching and Learning Strategies", London: Grasindo.
- [12]Maul, Ernita, and Ari Istiany, 2003,"Developing Instructional Materials that Applicative In Learning Basic Mathematic Teaching at the department of IKK FT UNJ, Jakarta". Research Report LPIU UNJ.
- [13] Ritonga, Abdulrahman., 1987,"Applied Statistics for Research", London: Publishing institution FE UI.
- [14] Riyanto, Orphans, 2001,"Educational Research Methodology", Surabaya: SIC.
- [15] Roberts, J., 1998," Language Teacher Education", London: Arnold.
- [16] Soemanto, Wasty., 1984, "Educational Psychology", Malang: Script Development
- [17] Suparno, Paul., 1997," Philosophy of Constructivism in Education", London: Publisher Canisius.
- [18] Soekamto, Toeti and Winataputra, 1996, "Learning Theory and Models Learning", Director General of Higher Education, Jakarta, MOEC.
- [19] Sudarsono, FX. 1996/1997,"Plan, Design and Implementation of Part Two", Director General of Higher Education in Jakarta, MOEC.
- [20] Sudjana, Nana, 1990,"Teaching and Learning Assessment Results", Bandung. P.T. Teens Rosdakarya.
- [21] Suparno, Paul, 1977,"Philosophy of Constructivism in education", Yogyakarta, Canisius.
- [22] Spiegel, Murray R, "Basic Mathematic", London: Erland, 1989.
- [23] Utomo, T., Ruijter, K., 1994, "Enhancement and Educational Development", New York: Scholastic.
- [24] Wayan Ardana, 1999," Konstruktivistics Learning: Concepts and principles, Learning Methodology Training Papers Constructivistic", Malang, 23 to 28 August 1999.
- [25] Wright, T., 1990, "Understanding Classroom Relationship role", in JC.
- [26] Richards and D. Nunan (eds), "Second Language Teacher Education", Cambrige: CUP.
- [27] Wantara, I Agus, "Mathematic for Business and Economics", Atmajaya University, 1998.
- [28] Wilardjo, Wirda., "Introduction to Social and Economic Mathematic", Bandung: ITB, 1995.
- [29] Joseph, John., Suryadi HS., "Basic Mathematic for Higher Education", Jakarta: Ghalia Indonesia, 1995.
- [30] Yousda, Ine I. Amirman and Zainal Arifin, 1993," Research and Statistics Education", London: Earth Literacy,
- [31] Zemanski, Sears., 1991, "Mathematic for the University 1", Jakarta: Bina Cipta.



# APPLICATION OF ASSESSMENT FOR LEARNING (AFL) TO IMPROVE STUDENT'S SELF-ASSESSMENT AND TECHNICAL SKILLS INVOCATIONAL EDUCATION AND TRAINING PROGRAM

Sudiyatno

Lecturer in Department of Mechanical Engineering Education , Engineering Faculty of Yogyakarta State University  
sudiyatno@uny.ac.id

This paper aimed to: 1) use AfL model to integrate assessment and learning in vocational education and training program, 2) increase student's self-assessment and student's technical skills by using AfL model during training, and 4) know if there is a significant difference on student technical skill between students assessed by using the AfL model and those assessed by using conventional assessment method.

Two methods of research were used in two different VET programs. Firstly classroom action research was done in diploma (D3) of Mechanical Engineering program and secondly quasi experimental method was applied in vocational senior high school. The AfL model was applied to assess student technical skill during training of lathe machining process. The subjects of this research were 8 teachers and 129 students of grade 11 of SMK N 2 Wonosari and 2 lecturers and 20 diploma students in FT UNY. Data obtained from the researches were analysed descriptively and by using anova.

The findings revealed that AfL model was perceived by teachers as a good manner in integrating assessment and training process. When using AfL model, teachers were much helped in assessing student performance by the ability of their students in doing self-assessment. Training process with AfL model showed that facilitated trainees by knowing the criteria of success of each job made trainees working more serious and independently. Based on the results of manova, it was found that there was a significant difference in student technical skills between SMK students assessed by using the AfL model and those assessed by using conventional assessment model

**Keywords** : assessment for learning (AfL), self-assessment, technical skill, vocational and education training, classroom action research, and quasi experiment.

---

## 1. Introduction

Unemployment which is mostly faced either by developing countries or developed countries is often caused by mismatch between skills obtained in schools and competencies needed by job providers. This problem becomes more complex in developing countries, because most jobseekers is graduate from elementary and junior secondary schools.

It is believed that vocational education can be used as the principal policy instrument for facilitating the transfer of youth from schooling to adult economic and social roles [1]. In addition vocational and technical education can make the worker more readily suitable for a given job and would him/her thus more productive [2]. Because of this, Indonesia increased the number of vocational senior high schools (SMK).

According to Joko Sutrisno [3], in 2010 the ratio of SMK and general high schools (SMA) was

50:50. There were 6,600 SMKs with about 4,3 millions students [4]. In this case, if there are no good planning and implementation, the significant improvement of the number of vocational schools will not directly reduce unemployment rate. UNESCO and ILO [5] gave specific recommendations to improve the effectiveness of learning process in technical and vocational education and training. Firstly, evaluation/assessment should be an integral part of the teaching and learning process. Secondly, learners should participate in the evaluation/assessment of their own progress, and the system should have in-built feedback mechanism to identify and correct learning problems. And thirdly, continuous evaluation of the teaching and learning process, including formative assessment.

In vocational education and training, the integration of learning and assessment should be implemented both in theoretical and technical-skills learning process. This integration is easier

and well known in theoretical learning process. But it has not been familiar yet in technical-skills learning process, such as in workshop. It is generally known that most practical teachers (trainer/instructors) assess the performance of students/trainees by assessing their products only in the end of semester. Therefore, how to perform assessment in technical-skills learning process so that learners could participate in the evaluation/assessment of their own progress, and the system could have in-built feedback mechanism to identify and correct learning problems? This paper aims to present results of the application of assessment for learning in vocational education and training.

## 2. Competency and Assessment

### 2.1. Competency

The meaning of “competency” according to Merriem Webster Online Dictionary is: 1) a sufficiency of means for the necessities and conveniences of life, 2) the quality or state of being competent. Spencer & Spencer [6], stated that a competency is an underlying characteristic of an individual that is causally related to criterion-referenced effective and/or superior performance in a job or situation. Competency is simply the ability to meet particular standards of performance required in the workplace. It can be concluded that an individual is competent, when she/he has achieved the standards of performance set down or is able in doing a such taskjob, that meet a minimum standard qualification.

### 2.2. Assessment of Competencies

Assessment is often defined as a process for obtaining information that is used for making decisions about students, programs, schools and educational policy[7] (. Educational assessment is a formal attempt to determine students’ status with respect to educational variables of interest [8]. Thus, assessment in a competency-based education and training is the process of determining whether a student/trainee has acquired the unit/unites of competencies set down as outcomes of that course.

Position of assessment in competency-based education and training can be explained as shown in Figure 1. Traits and characteristics are the foundation of a performance in demonstrating competencies. Through learning process, students/trainees develop their skills, abilities and knowledge. Different combinations of skills, abilities and knowledge will develop different competencies. Finally different competencies possessed by an individual are combined in carrying out different demonstrations or tasks [9]. In this hierarchy, assessment should be applied in every step from observing individual traits and characteristics to assessing individual performance by demonstration .

Two tools needed in doing an assessment in competency-based education and training are the instruments and procedures. The tools are used to gather and also to intepret evidence of a unit competency. The first tool is an instrument which is the activity or specific questions used to assess competency by the assessment method previously selected. The secong tool is procedures which are the information or instructions given to the candidate and the assessor about how the assessment is to be conducted and recorded [10].

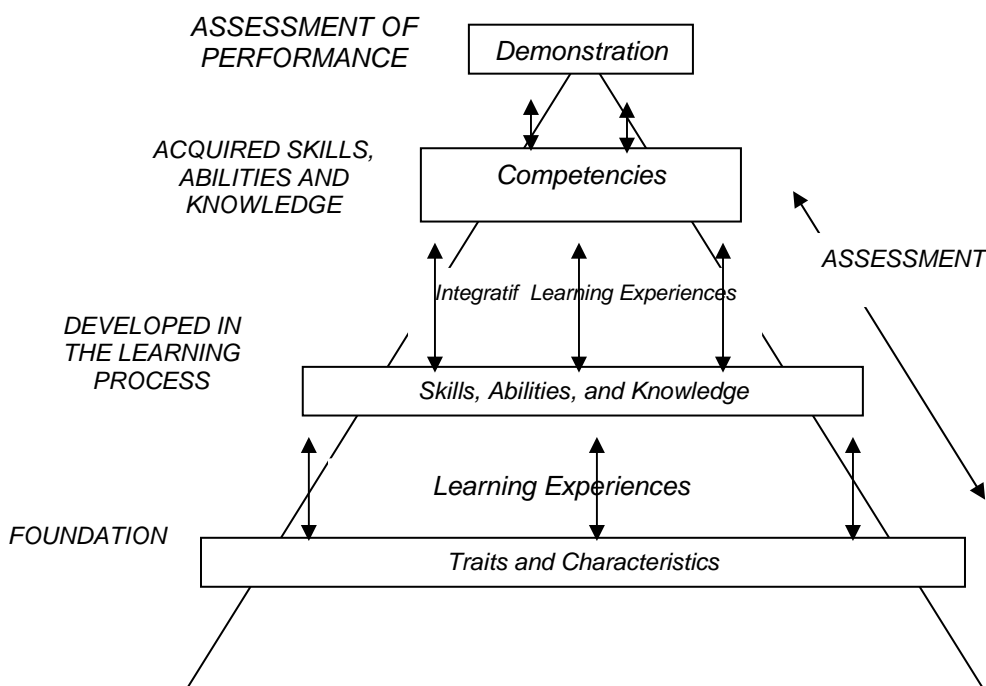

Figure 1. A hierarchy of Postsecondary Outcomes

### 3. Assessment for Learning (AfL)

Assesment for learning is the process of seeking and interpreting evidence for use by learners and their teachers to decide where the learners are in their learning, where they need to go and how best to get there [10]. Therefore this model of assessment is developed to help students having self direction of learning and teachers should provide an individual constructive guidance to students.

There are ten principles of AfL: a) AfL should be part of effective planning; b) AfL should focus on how students learn; c) AfL should be recognised as central to classroom practice; d) AfL should be recognised as a key professional skill for teachers; e) AfL should be sensitive and constructive because any assessment has an emotional impact; f) AfL should take account of the importance of learner motivation; g) AfL should promote commitment to learning goals and a shared understanding of the criteria by which they are assessed; h) Learners receive constructive guidance about how to improve; and i) AfL develops learners capacity for self-assessment so that they can become reflective and self-managing [10].

To be more helpful in practice, teachers should do three linked aspects of assessment [11]. Firstly, day to day assessment to provide a wide range of evidence of learning in specific contexts. Secondly, periodic review of the evidences compiled to give more comprehensive profile of learner's achievement. In this step, teachers and learners can make broader review of progress across subject. Thirdly, transitional assessment where teachers can use external tests or tasks and make reports to parents and next teachers.

### 4. Assessment of Technical-skills

Skill learning process conducted in a workshop is intended to help students to learn new skills. Teachers arrange the learning process by giving jobsheets and instructional sheets to students. Then, students make preparation worksheet before doing the task. While students are working the job, teachers are observing and guiding when needed.

There are several basic procedures in teaching technical skills: a) each taskjob which introduces new skills should be given in addition to those already mastered by students; b) practicing new skills should begin as soon as possible after they have been demonstrated; c) It is well known that "practice makes perfect", so that teachers/trainers should provide an opportunity for students to do repetition; d) instructional sheets should be provided to guide students through the practice steps of the learning job.

Three aspects assessed in this learning of technical-skills are working attitudes, working procedures and quality of product. A list of performance statements which are derived from the three aspects is shown in Table 1. Instrument used in this assessment is an observation checklist including clear instructions for assessors (teachers/trainers) and candidates (students/trainees). Teachers use the checklist to gather evidence and take structured notes that can be used as feedback and to enhance objectivity of the assesment decision.

Table 1. Aspects of Technical Skills Assessment

No.	Aspect	Item
1	Working Attitudes	Dicipline
		Good conduct
		Proper dressing
2	Working Procedures	Proper setting steps
		Proper procedure of using tools and machine
		Proper procedure of using measurement tools
		Good in doing maintenance
		Conducting safety work
3	Product	Fitness of workpiece dimensions

### 5. Case Study of AfL

#### 5.1. AfL Application in FT UNY

AfL was applied in a teaching shop at Engineering Faculty of UNY, where 20 diploma students involved [13]. The students were practicing lathe machining process to produce three different gears: spur, helical and bevel gears.

Two lecturers were involved in this case study. Method used was classroom action research. This research was conducted in three cycles. Two different observation checklists were used. The first checklist used by lecturers to assess student performance and the second checklist was used by students to do self-assessment. Each cycle consisted of planning, acting, observing and reflecting.

Results of this study were shown in Table 2. At the first cycle, it was found that the average score of working attitudes was 29.3. The average score of working procedures was 16.67. The average score of product quality was 58.25. At the second cycle, it was found that the average score of working attitudes was 67.67. The average score of working procedures was 56.67. The average score of product quality was 64.5. At the third cycle, it was found that the average score of working attitudes was 88.33. The average score of working procedures was 82.83. The average score of product quality was 97.5. It can be concluded based on the

results that application of AfL had improved student's technical skills in all aspects.

Table 2. Average Score of Technical-Skills Assessment

Aspect	Cycle 1	Cycle 2	Cycle 3
Working Attitudes	29.3	67.67	88.3
Working Procedures	16.67	56.67	82.3
Quality of Product	58.25	78.75	97.5

### 5.2. AfL in SMK

In the second case, AfL was applied in a teaching shop at SMK N 2 Wonosari and SMK N 2 Pengasih, where 129 students practiced lathe machining process [14]. Eight teachers were involved in this study. Method used was quasi experiment. As the experiment group was students assessed by using the AfL model and as the control group was students assessed by conventional assessment method.

Process of technical-skills learning by using AfL model was divided into three parts. At the beginning, teachers explained the criteria of success in doing the taskjob and gave jobsheets and workpieces to each student. While students were doing the job, the teachers went around to observe

and guide the students. Teachers also assessed students working attitudes and procedures by using the observation checklists. In the end of the learning process: a) students filled a form of day to day report, b) teachers gave feedback to students based on the notes of observation.

This research was conducted in one semester. Three skills of learning targets, i.e. attitude, cognitive and psychomotoric skills, as dependent variables were assessed. As the independent variable was the use of AfL model in technical-skills learning. There were three kinds of instrument: two observation checklists were used to measure attitude and psychomotoric skills and knowledge test was used to measure cognitive skills.

Data obtained from this research were analysed by using MANOVA to examine whether there was significant different student performance between the experiment group and the control group. The results of this study are shown in Figure 3. It is revealed that based on Pillai's, Wilk's, Hotelling's and Roy's procedures, the value of Sig. was 0,000 which is smaller than 0,05. It was concluded that there was a significant difference in student performance between students assessed by using the AfL model (the experiment group) and those assessed by using conventional assessment model (the control group).

Table 3. Results of Multivariate Tests<sup>b</sup>

Effect	Value	F	Hypothesis df	Error df	Sig.	
Intercept	Pillai's Trace	.998	2.228E4 <sup>a</sup>	3.000	138.000	.000
	Wilks' Lambda	.002	2.228E4 <sup>a</sup>	3.000	138.000	.000
	Hotelling's Trace	484.426	2.228E4 <sup>a</sup>	3.000	138.000	.000
	Roy's Largest Root	484.426	2.228E4 <sup>a</sup>	3.000	138.000	.000
Group	Pillai's Trace	.786	1.694E2 <sup>a</sup>	3.000	138.000	.000
	Wilks' Lambda	.214	1.694E2 <sup>a</sup>	3.000	138.000	.000
	Hotelling's Trace	3.682	1.694E2 <sup>a</sup>	3.000	138.000	.000
	Roy's Largest Root	3.682	1.694E2 <sup>a</sup>	3.000	138.000	.000

a. Exact statistic

b. Design: Intercept + Group

### 6. Conclusion

The findings revealed by the two case studies show that AfL model was perceived by teachers as a good manner in integrating assessment and training process. By using AfL model, teachers were much helped in assessing student performance by the ability of their students in doing self-assessment. Training process with AfL model facilitated trainees improved their performance by

knowing the criteria of success of each job and made the students working more serious and independently. Based on the results of manova, it was found that there was a significant difference in student technical skills between SMK students assessed by using the AfL model and those assessed by using conventional assessment model.

## REFERENCES

- [1] Barnett, K. & Ryan, R. (2005). *Vocational education and training in Australian schools: issues for practitioners*. International Education Journal, ERC2004 Special Issues, 5(5), 89-104.
- [2] Tilak, J.B.G. (2002). *Vocational education and training in Asia*. Retrieved on 21 Juni 2011 from [www.norrag.org/wg/documents/Vocational\\_technical\\_educat.doc](http://www.norrag.org/wg/documents/Vocational_technical_educat.doc)
- [3] Joko Sutrisno. (2007). *Kebijakan pengembangan SMK*. Makalah Seminar Nasional: Kebijakan Pengembangan SMK dan Sertifikasi Guru SMK. Fakultas Teknik - Universitas Negeri Yogyakarta
- [4] Kompas, 3 June 2008
- [5] Unesco & ILO. (2002). *Technical and vocational education and training for the twenty-first century*. Retrieved on 19 Juni 2011 from <http://unesdoc.unesco.org/images/0012/001260/126050e.pdf>
- [6] Spencer, L.M & Spencer, S.M. (1993). *Competence at work: Models for superior performance*. Canada: John Wiley & Sons, Inc.
- [7] Nitko, A.J. (1989). Designing tests that are integrated with instruction. Dalam Robert L. Linn (Editor), *Educational Measurement*, (3<sup>rd</sup> Ed.), London: Collier Macmillan Publisher.
- [8] Popham, W.J. (1995). *Classroom assessment: What teachers need to know*, Boston-USA: Allyn and Bacon.
- [9] National Center of Educational Statistics. (2002). *Defining and assessing learning: Exploring competencies-based initiatives*. Retrieved on 10 Maret 2006 from <http://nces.ed.gov/pubs2002/2002-159.pdf>
- [10] Assessment Reform Group. (2002). *10 principles of assessment for learning*. Retrieved on 19 Juni 2011 from [www.assessment-reform-group.org/CIE3.PDF](http://www.assessment-reform-group.org/CIE3.PDF)
- [11] Department of Education and Training. (2008). *Designing assessment tools for quality outcomes in VET*. Retrieved on 19 Juni 2011 from <http://www.milesmorgan.com.au/assets/Downloads/Designing-assessment-tools-for-quality-outcomes-in-VET.pdf>
- [12] Paryanto & Sudiyatno. (2010). *Penerapan model assessment for learning (AfL) pada pembelajaran praktik pemesinan di Jurusan Pendidikan Teknik Mesin FT UNY*. Yogyakarta: FT-UNY
- [13] Sudiyatno (2010). *Pengembangan Model penilaian komprehensif unjuk kerja siswa pada pembelajaran berbasis standar kompetensi di SMK Teknologi Industri*. Disertasi – Pascasarjana UNY

# ENHANCING THE LEARNING QUALITY THROUGH IMPLEMENTING INSTRUCTIONAL DESIGN FOR VOCATIONAL EDUCATION

**M. Bruri Triyono**

Yogyakarta State University  
bruritriyono@yahoo.co.id

## **Abstract**

The impact of information technology on education will be realistic, especially in the learning process in vocational education institutions. Learning in vocational education both theory and practice of demand variation learning and instructional strategies in accordance with the teaching materials and areas of expertise. Technological developments in the field work, the characteristics learners, completeness of facilities and infrastructure are factors to be considered in determining the instructional strategies which is used to achieve the learning objectives and skill competencies. Lack of understanding and preparing of educators, especially to determine the model of learning and appropriate instructional strategies is a factor that causes the learning experience of students is not optimal. Educators will be easier to implement instructional when they are learning to understand and be able to prepare for learning by creating a complete instructional design. Instructional design is a complete guide to improved quality of learning achieved.

The system instructional design is a method of learning how to plan and prepare complete learning activities. Sequence in the design of instructional begins with a need analysis. It is good to know the needs of the competence of learners and the fieldwork, knowing the characteristics of learners so that the application of learning can be accomplished in student center learning. The second step is to select and define indicators of competence, followed by analyzing each of the indicators of competence. The third step is to develop learning, beginning with determining the instructional strategies and teaching materials to be used. The final step of the instructional design is to make evaluations about the performance of instructional design itself and prepare both the summative and formative test.

Through understanding of how to prepare and to make of instructional designs will bring more educators to implement various models of learning, especially involving the activities of learners. Match between the needs of learners competency skills and the field work will be easily achieved through the application of instructional design were made based on internal and external conditions in vocational education. This will impact on improving the quality of learning and learning experiences of learners.

**Keywords:** learning quality, instructional design, vocational education

---

## **1. INTRODUCTION**

The development of information technology impact on education, especially in the learning process in vocational education institutions. Learning is no longer monotone in the classroom with single information from educators, but has made use of the environmental conditions and information from various sources that can be searched and acquired by learners themselves.

Learning in vocational education both theory and practice of demand variation and learning strategies in accordance with the teaching materials and areas of expertise. Mastery of skills both physical skills and intellectual activity involving learners directly using equipment similar to the actual equipment during the learning process takes place. Use of equipment in an atmosphere of learning that match the real or actual conditions in

the field work and the use of strategies for its delivery demonstration shows characteristics of student center learning. Three aspects in learning motor skills were demanding performance, perceptual, and cognitive (Kevin O'Neil, 1997:76).

Technological developments in the field work, the characteristics and needs of learners, completeness of facilities and infrastructure are all factors into consideration in determining the learning strategies to learning objectives for achieving the skill competencies. Lack of understanding of the preparation of educators, especially to determine the model of learning and appropriate learning strategies is a factor that causes the learning experience of students is not optimal. Educators will be easier to implement when they are first learning to understand and be able to prepare for learning by creating a complete learning design that includes determining the

learning strategies. In this study will be discussed how and anything what you need to know to make the learning design, because design is a complete learning guide to improving the quality of learning have been achieved.

## 2. INSTRUCTIONAL

Instructional in general we know as the process of educating, starting from the stage of preparation to examination of the learning experience of students as the latter part of that process. The process is not simply the interaction between educators and learners but covers various aspects including actors, goals, tools, and strategies that support and interrelated so that the thing more clear in process. Aspects of the perpetrator is a condition of learners and educators, is an indicator of objective aspects of knowledge, skills and behaviors desired changes happen after the learning takes place, this aspect is the completeness of equipment that should be provided and used to facilitate the learners perform in accordance with objective aspects, and aspects of the strategy is tips or tricks that are used to facilitate the implementation of the learning is viewed from the side of educators and learners. Instructional design itself is planning or instructional design created to facilitate the learning process is progressing well in accordance with the learning goals.

Instructional cannot be separated with a study of instructional systems development. Various books on instructional development systems have more similarities than differences, particularly in terms of process steps or activities of instructional. Foshay W, Silber K and Westgard O (1986) details the instructional process of assessing the learning needs which include; a) the relevance of student characteristics, b) the characteristics of work, c) the performance of field work, d) the task or job, and e) analysis contents of the field work that will be studied. The next process is to write a statement about the purpose of performance or goal of learning, develop performance assessment, divide the stages of learning, determine instructional strategies, designing instructional materials including the media, and finally evaluating instructional activities.

CB Leshin, J Pollock, and Reigeluth CM (1994), classify the process into five stages and is called the method of determining the tactics and strategies in instructional design. This method is a series that began the process of requirement analysis phase, followed hierarchy and the selection of learning content, learning development, and final evaluation of learning. In terms of needs analysis is very close to the ways of determining the need for mastery of areas of expertise in vocational education. Factors that influence each competencies will be taught an in-depth review at the initial step that determines the next design step.

The analysis starts with the needs of the field of what skills will be learned, why it is needed, the task or what jobs are needed to complement his skills, how to view their performance, how to measure performance, and concluded with how learning stages. Of the two books demonstrate the similarity term planning process to discuss the design of instructional activities, while they also do not discuss the implementation of learning, although formative and summative tests reveal to learners from the implementation of learning that can be used as one measure of success in instructional design.

## 3. TERM OF EDUCATION AND TRAINING

Discussion instructional design for vocational education is closely related to terms of education and training. Both of these domains differ in terms of objective reality but it cannot be separated. In the domain of formal education, learning undertaken usually follows a prescribed curriculum. Instructional planner match stayed with conditions in the workplace or in need, the difference would be whether the material being taught is in conformity with the establishment of competence for students. Information about the suitability level of competence obtained through validation taught expert on the subject of planning or material will be taught, while the need for environmental competence through observation and participant students. Through the collection of these data are further processed to determine the design instructional. Weaknesses that will emerge after the process of learning takes place is the possibility of graduate education has been lagging competencies with the competencies required due to the range of education a long time, but when viewed from the many indicators of competence that has been mastered will bring the impact of graduates the flexibility to quickly adapt to the competence who has developed it.

Domain training is similar the concept of non-formal education. Learning is carried out usually to complement or add to the knowledge and skills of trainees. Importance of training for education can be seen from the rapid growth of technology in employment both formal and informal sectors are not easily followed by learning activities in the domain of education. While learning in training refers to the competencies directly related to the world of work. In accordance with the consumption of a relatively short when compared with education, the training is more appropriate if carried out in times of need alone. Although the implementation is short, but the competencies acquired by graduates of training the workforce competency needs more precise, this is a guarantee that must be accomplished and fulfilled by training providers. The disadvantage is the stock of knowledge to complete the acquisition of

competence is very little that is less able to adapt

Although there are differences especially in terms of objectives and implementation time, but the process of learning to equip students with the skills of participants have in common, even for vocational education students achieving competency based curriculum will not only but combines with the achievement of competence training model. Mapping of competence based curriculum alone will keep control of the competence of learners with competency requirements in the world of work. In the same area of expertise with the world of work, competencies can be planned together but the determining indicator of competence can use the competency requirements in accordance with the development needs in the world of work, this condition is the same as the determination of competence to make the instructional design training.

#### 4. DESIGN INSTRUCTIONAL IN VOCATIONAL EDUCATION

Vocational education is a different kind of education with general education in terms of providing learning experiences that must be mastered by learners. Vocational education graduates have specific skills that can be used for work, while general education graduates do not have the skills to work. These conditions correspond to one of the twelve characteristics of vocational education (Proser: 1980), which provides learning experiences of learners in the form of mastery of both physical and intellectual skills and competencies needed the world of work. The following types of skills competencies required by the type of work the working world, more and more areas of work with various skills in the workforce will affect the variation of the type area of expertise held or opened by a vocational education. On the other hand, general education

when faced with changes in working conditions.

provides the same mastery of knowledge for learners and variations in the type of education do not have certain skills that are used for work, basically a learning experience that they get used to pursue higher education in college.

The difference of education is certainly a consequence of learning at least when viewed from the side of methodology, teaching materials, media and equipment used. The difference is clearly seen in the practice of learning, whereas most of the subjects of learning in vocational education are equipped with practical activities. Practical activities in vocational education used to train the appropriate skills with skills in the world of work and held in laboratories, studios, and workshops are made similar to the operation later. While in general education, learning practices largely implemented only in a laboratory to prove the concept. These conditions require different instructional design prior to the time when deciding on the indicators of competence and the learning stage.

In general, educators have to understand how to teach the subjects of study or training or specific subjects based on the experience and the content of teaching materials, but whether they regularly update the content tailored to the needs of learners, technological developments, the demands of employment, whether the media and materials are always updated in order not boring, whether the learning experience of students is in conformity with the purpose of learning, and many other questions surrounding the success of learning. Check the condition and this will always be repeated recheck accordance with the course of the cycle in the learning system (Figure1). Yet a review of what is taught is an obligation that should consciously be implemented by educators periodically or according to the development of the environmental conditions studied.

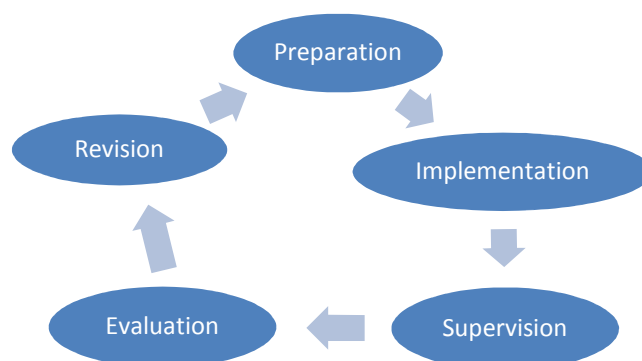

Figure 1. Learning cycle



The preparation stage is the completeness of the activities of educators to prepare various learning and provide information about learning activities that will be carried out to students, the implementation phase is the delivery of core activities subject lessons, stage inspection is an activity to know how far learners have mastered the learning. Phase checks are not always carried out after all the explanations given will be completed but more a part of that learning can be partially successful. Stage of the evaluation carried out on two conditions ie conditions mastery learners after learning through formative and summative tests, and the condition of interaction and learning materials themselves through questionnaires or interviews with learners. The data from the evaluation stage coupled with the information needed data were then analyzed to determine the content or activities on the revision stage. The results of the revision are materials for learning in the next period.

## 5. CONTENT OF INSTRUCTIONAL DESIGN IN VOCATIONAL EDUCATION

In this discussion, applied approach to the determination of the real on the steps of the process of designing a particular point on the learning practice in vocational education, while learning to be able to use instructional design theory in public schools. The approach was attempted based on the latest information the results of observations and interviews with experts in the field of vocational education and instructional media, an expert in the field of industry expertise in both technology and services and a plot with a qualification in the field of vocational education expertise. For ease of understanding, it discusses the four activities of the instructional design system of CB Leshin, J Pollock, and Reigeluth CM (1994) but the sub-activities are tailored to real needs in vocational education. These activities are: needs analysis, selection and sequence of lesson content, lesson development, and instructional evaluation. Each activity will discuss about the sub-activities that are carried out in stages in accordance with Figure 2.

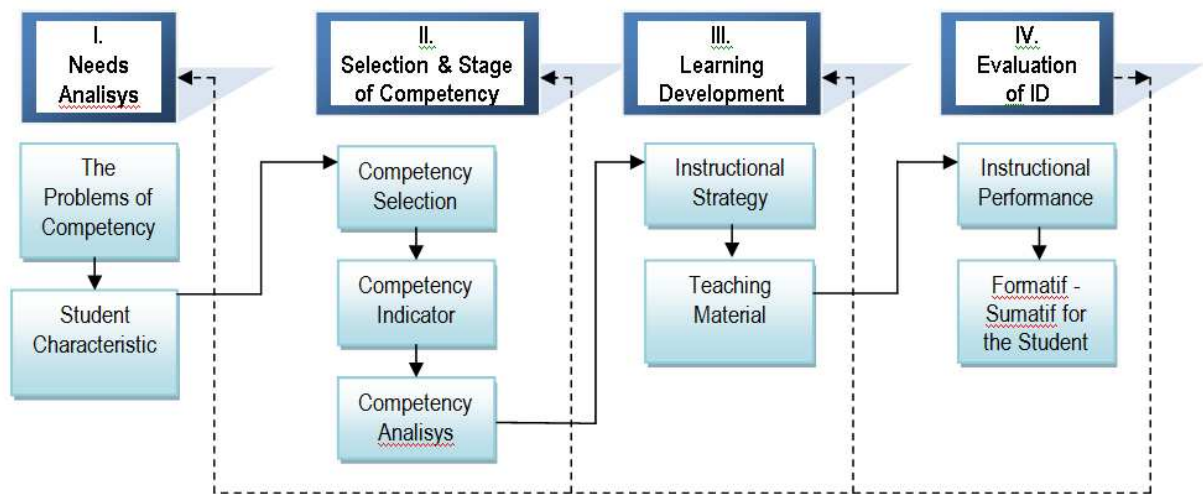

Adaption from CB Leshin, J Pollock, and Reigeluth CM (1994)

Figure 2. The Model of Instructional Design in Vocational Design

### 5.1 Need Analysis

Discussing the need for an analysis of any design is also not free from the understanding of the importance of design itself. As a building, whatever its form should be as simple as there are plans to initiate the building can be erected. The plan begins with the question why should the house, after which it will be many variations of the information should be collected to build a house. From the answers the needs of developing homes on wide range of information or the size of house, location, financing, architecture, materials, time, civil drawings to the phasing of the building until

the house is planned so. Is a string of stage design activities, while the implementation of home-making and whether the house is convenient for the owner occupied is an activity after another.

In this step is indicate that ID needs information. The information is used to define the problems and analysis how to solve them. The problems usually are lack of competency in the field work and what will be held by the vocational education to solve those problems. In line with that problem is the data about characteristic of student or participant that want to follow the program of learning in the vocational education. In the end of this step, we need some verification in the field

work especially to know the problem and close to the really task and job that suitable and needs in Indonesia field work. Here is the content of need analysis:

The Problem of Competency needs information about:

- Define what is the problem like
- Why its competency is needed
- How to fill that,
- Make summary

The Student Characteristic:

- Define who are the students
- Why do they need the competency
- How to fill that
- Summary

## 5.2 Selection and Stage of Competency

Step 2 and 3 are the job of the teachers or educators. They usually do this to completely the lesson plan. The competency selection is to make a list competency that close to the main problem and define the main competency. The main competency is an object learning that will be designed and implemented by the vocational education. Based on the main competency we have to find information of the data about the kinds of the job, task, and performance in the domain of its competency.

The competency indicators are parts of main competency. They must be achieved completely by the student to get the main competency. The hierarchy of each competency indicator is important, with this can be know which one the first as a prerequisite to the others indicators. The map of competency achievement is to make easy the condition learning of the students.

The competency analysis is to define performance of each competency indicator. The performance is the skill that can be observed and valued. We have to make in detail and single performance in competency indicator. According to the demanding of competency, the performance assessment must be made proper to each indicator, because the performance assessment will be key point of process learning. The goal of learning or learning objective is based on performance assessment, which means in this chapter the designer should write in detail the learning objective. The structure of learning objective usually is formed by verb, standard performance, and condition. Here is the content of this step.

Competency Selection:

- List of competency that close to the problem
- Define the main competency
- Define the main performance of competency

Competency Indicators:

- Define the competency indicators
- Arrange in a series of the competency indicators

- Make a map of competency achievement

Competency Analysis:

- The performance of each competency indicator
- The performance assessment of each competency
- Write the goal of each competency indicator

## 5.3 Lesson Development

The learning development is the plan of the teacher to fill the learning activity with the student. In this book will divide in two steps, they are instructional strategy and learning material. Instructional strategy is like the method, but it is depend on the condition of learning. We can define the deferent strategy although in the same subject learning. The aspects that influence the instructional strategy are type of learning, characteristic of student, capability or qualification of teacher. Instructional strategy as a method has four activities. Stage of the lesson is interaction between teacher and student. In this stage has three parts, they are preparation, core of learning, and feedback. Preparation is to make student aware to the learning process, have motivation and ready to accept the lesson. Core of learning is process to present the subject learning. Feedback is activity to check the student achievement in subject learning.

The method of instructional means method of teaching. Teacher will choose the proper method in case of the kind's subject learning. There are a lot of teaching methods and to use it depend on the condition or field situation when presenting the subject learning.

To use the media instructional is depend on the qualification of the teacher and availability of equipment to make that media. Computerize in media instructional has helped a huge problem in interaction learning in education. We can use three dimensional programs simulation to present artificial object and moving object without using the real equipment. It will save the time and money.

Time consuming is important to give limit in process learning. In case of practice learning, the teachers should be tried them self to do the job sheet before it is given to the student. The teachers define the time consuming to finish the job is based on the learning activity, not in real job in the field work.

Teaching material is the some material that used to help teacher completely the presenting of subject learning. To define what the material is properly to the learning process, we have to look the type of learning (theory or practices).

The kinds of teaching material are modules, books, information sheets, job sheets, hand out, work sheet, manual book, and the others material that needed by the process learning.

The source academic means someone who has well in skill and knows about the subject learning to

make that teaching material. The source material make easy the teaching material. To make sure that material is useful in learning activity; the teaching material should be tried in small group of student and checked the content by the expert in similar subject learning. Here is the stage of step 3.

Instructional Strategy:

- Stage of the lesson
- Method of instructional
- Media instructional
- Time consuming

Teaching Material:

- Type of learning
- Source academic
- Source material
- Tryout in order to suitable in learning activities

#### 5.4 Instructional Evaluation

Instructional evaluation is used to guarantee the success of learning process. We use two kind of view, they are expert and student. The expert to evaluate the system design, the content of learning and the goal of competency according to solve the main problem. For the students as object learning, they will give feedback about acceptability of instructional design. In this case of evaluation, it used methodology in evaluation research. Here is two kinds of evaluation in the instructional design.

Instructional Performance:

- Define the expert in education
- Evaluation the step of design
- Evaluation the content of learning
- Evaluation the competency

Summative Formative Test:

- Define the group of student
- Formative test to know the acceptable of design
- Summative test to know the student achievement

#### 6. CONCLUSION

Instructional design in vocational education is deferent with the general education especially in the laboratory or workshop learning. To know how to prepare instructional design, we need information from field work and internal condition in the school or college.

means the availability and condition of material to

The instructional design has four steps. There are needs analysis, selection and stage of competency, lesson development, and instructional evaluation.

Through understanding of how to prepare and to make of instructional designs will bring more educators to implement various models of learning, especially involving the activities of learners. Match between the needs of learners competency skills and the field work will be easily achieved through the application of instructional design were made based on internal and external conditions in vocational education. This will impact on improving the quality of learning and learning experiences of learners.

#### REFERENCES

- [1] Cynthia B Leshin, Joellyn Pollock, Charles M Regeluth. 1994. *Instructional Design Strategies and Tactics*. Educational Technology Publication Inc: Englewood Cliffs New Jersey
- [2] Foshay W, Silber K and Westgard O. 1986. *Instructional Design Competencies: The standards IOWA City, Iowa: International Board of standard for Training Performance and Instruction*
- [3] Helen Garrett, Judith Taylor. 1994. *How to Design and Deliver Equal Opportunities Training*. Kogan Page Limited: Pentonville road London
- [4] Kevin O' Neil, (1997) *Planing, Skill, and Strategies for Teaching Technical and Vocational Subjects: Universitas Brunei Darussalam*
- [5] Kidd and Leighbody, (1968) *Methods of Teaching Shop and Technical Subjects: Canada, Delmar Publisher USA*
- [6] Lynnette B Erickson, Nancy Wentworth. 2010. *Tension in Teacher Preparation: Accountability, Assessment, and Accreditation (Advance in research on teaching)*. Emerald Group Publishing: Wagon Lane, Bingley BD16 1WA, UK
- [7] OECD. 1996. *Assessing and Certifying Occupational Skill and Competences in Vocational Education and Training*. Head of Publication Service, OECD: Paris
- [8] Peter Westwood, (2008) *What Teachers Need to Know about Teaching Methods: Victoria, Acer Press Australia*
- [9] Tony Nasta. 1994. *How to design a Vocational Curriculum (a practical guide for schools and colleges)*. Kogen Page Limited: Pentonville Road London N1 9JN
- [10] UNESCO-UNEVOC. *Instructional Design for Vocational Education*. e-forum@unevoc.unesco.org , date 19 October 2010 until 03 Desember 2010
- [11] M. Young, *The Technical Writer's Handbook*. Mill Valley, CA: University Science, 1989.

## THE MAPPING OF VOCATIONAL HIGH SCHOOL'S PROFILES IN WESTERN INDONESIA

Nizwardi Jalinus, Ganefri, Syahril

Padang State University  
nizwardijalinus@gmail.com

### Abstracts

The aim of this study is to identify the Strengths and Weaknesses of Vocational High School in in western part of Indonesia. Based on the concept of Government policy that to overcome unemployment of the youngster grow rapidly in recent years. The vocational and technical education development is a way to create a job opportunities for the youngster. The government has a target in the year of 2020 the ratio between vocational high schools and General High Schools is 70: 30. The government has a target in the year of 2020 the ratio of vocational high schools and General High Schools is 70: 30. The objective of the vocational education program is to improve the quality of students graduates to be saleable in the job market as well as be competent to create the jobs.

The main problem of vocational education and training is how to provide the workforces to be competent in the world of work, and thus who have competencies to competitive in the job market. However, some indicators appear that the vocational high schools commonly lack of school facilities such as equipments, learning facilities etc, lack of professional teachers performances, lack of student motivation, the unstable growth of students behaviour in term of an affective domain etc, lack of financial support as well as lack of industrial experiences etc. The purposes of the study is to identify the teachers qualification in term of the field of study, amount of teachers based on their subject of teaching, including type of programme offering in the schools.

This study focused to search the vocational high schools profiles in West Sumatera.(one of the province in the western Indonesia which is located in Sumatera Island). The survey had been conducted by observing, interviewing and documenting data for a couple of months in 2009. The result of study covered 77 public Vocational High Schools (SMK) and 88 privates SMK) in 18 regions in west Sumatera Province.

The result of study revealed that 40 program of studies and 121 types of competencies had been developed, the most developed field of study in the schools is technology and engineering area and followed by business and services, although the economic potential trend to be in the agricultural area,business and trades, hotels ,tourism, and restaurant.

Majority teachers' qualification are bacheleurete (S1) and acta IV (setificate of teaching for high school level). But, West Sumatera do not have enough teachers in the field of accounting,hotels and tourism, marketing and computer network. Teachers commonly lack of experiences in the field of work particularly in the field of engineering, business and tourism.

Finally, this study recomended that the government should support the vocational high school programmes by developing the budget of vocational education and training based on the potential economic of the region.

**Keywords :** *Mapping, SMK, the field of membership, students, teachers.*

---

### 1. Introduction Preliminary

Indonesian communities willing that their children go to Vocational School (SMK) public and private sectors increased sharply. Comparison between the applicants to those accepted was 49.8% in 1995/1996. Comparison between the accepted applicants was 49.8% in 1995/1996. While in 1997/1998 comparative figures are small, namely 43.1% more applicants means more than the previous year. While in 1997/1998 comparative

figures are 43.1% smaller that means applicants Greater than the previous year.

This increase is is a positive thing, Because it can provide a picture of public confidence in the world of vocational education, but on the other hand vocational capacity of the country,is limited. This can encourage the growth of the private vocational school to start working more widely. In 1993/94 the comparative figures with SMU SMK is 35:65%, then the figure rose menyadi 37:63% in

1997/98. In the year 1993/94 with comparative figures vocational high school was 35:65%, then the numbers go up becoming an 37:63% in 1997/98.. Seeing this trend figures are Likely to continue to rise for the following years, where the government has launched a comparison with the vocational high school in 2020 was 70:30%.

The crisis is affecting an increasing number of high school graduates (high school) whom Could not go to the higher education. Many high school graduates who can not go on to college has become a very heavy burden for the government on the issue of unemployment and job vacancies, with the argument that graduating seniors are not ready to work and lack of work competencies. As such, the Government seeks to encourage the development of Vocational School (SMK ) in all Districts / cities, with expectations that vocational graduates are able to work and opened his own employment. The goal is how the graduates is capable to enter the Labor Market ,So they have to master the vocational subjects as well as competence in practical skills.

Analysis of SMK development , there are three possibilities that can be occurred in the future, there is the program of expertise that will grow rapidly, the natural skill program development, and programs that will be saturated. The Program of expertise is projected to grow very rapidly is a group program of Agriculture, Tourism, Fisheries, Marine, and Information Technology. It is estimated that by 2020 the number of vocational courses that will open the 6151 proficiency level achieved. Group is quite stable and projected program will have the proper development of the technology programs and industry groups as well as Arts and Crafts Group, is expected to reach 3178 SMK who ran the program.

While groups of Business and Management program is projected to be saturated i n the job market and the amount will be reduced in 2020. Approximately only 923 SMK which organizes the program. The development of SMK need efforts to achieve 70% compared to SMU, of course, will need human resources who are competent in the specialty, so the management of SMK will achieve higher efficiency and effectiveness.

The success of a board of education (SMK) to achieve the desired goal depends on the human resources to manage the institution. The human resources urgently needed are teachers who carry out learning activities in a vocational schooling. In addition to supported learning activities need the facilities such as , full of learning media, advanced practice tools and machining, curriculum etc are owned. The role of teachers in learning activities at the Vocational High School, should be able to teach and Develop learning skills and capabilities in accordance with the material being taught.. Teacher as a resource persons in the School (SMK) has a

crucial role and he is the Key to Success in Achieving educational goals, Because teacher is a manager in the implementation of teaching and learning activities.

Some of the implementation of this learning to work effectively and efficiently in accordance with the teaching they should be prepared and qualified professional teachers meet the needs of every good school associated with the number, qualifications and specialized. This is in accordance with article 42 paragraph (1) National Education Law Number 20 Year 2003 on National Education System stating that the teacher as an educator must have a minimum qualification and certification in accordance with the levels of teaching competence, physical and spiritual health, and have the ability to create educational purposes nationally.

Thus, teachers must have a qualification requirement, competencies standard, and able to support and maintain a professional education that will produce a good quality of education.

Based on the quality of existing teachers, it is still a lot of our teachers who have not qualified as teachers as required under the Act on National Education System. Not only in Indonesia, teacher qualifications still meet minimum requirements, but the same has been experienced by large population countries.

The conclusion of discussion during the meeting of education ministers of nine countries a large population of the states that only about 50 percent of teachers with graduate education and educational background requirement . In Indonesia, only a third of teachers' educational background equivalent to a bachelor degree. While in Indonesia, only a third of teachers 'educational background equivalent to Undergraduate level.

Data teachers in 2008 stated that the number of teachers in public and private schools reached 2,365,237 people Nationwide. While the data in 2001 indicate that teachers who meet the qualifications for kindergarten (TK) of 9.8%, 46.1% of elementary school, junior high of 85.4%, 66.2% of high school, and SMK 56 , 4%. overall only 56% qualified teachers.. In addition to the Qualifications that are not in accordance with the minimum requirements, there are many teachers whose expertise is not in accordance with what is taught. this will impact on the ability of teachers in implementing effective learning, meaningful and enjoyable.

## 2. Problem Summary Problem Formulation

The real situation on the ground indicate that the quality of education remains low and appear unable to meet the needs of community. One reason, it can be caused by the low quality of teacher education or it is not sufficient availability of both quantity and quality .Characteristics of programs in vocational skills that are Likely to

fluctuate, this is due to the existing Labor requirements also vary, according to the needs of existing jobs in the community. These changes will certainly influence the number of teachers of SMK.

Based on the needs and situation analysis of state school teachers conducted by the Directorate Dikmenjur concluded that the number and specialties of the side still has a shortage of teachers, while the other side had the advantage. Excess or shortage of vocational teachers were scattered on the teachers' Normative, Adaptive, and Productive programs in all Provinces. Condition of excess and shortage of teachers in vocational occurring from year to year is a fairly complex problem and requires a good strategy in the process of completion. The state of problem of excess and shortage of teachers needs to be done through a mapping of the vocational school that exists in the fields. How do potential (Normative Teachers program, Adaptive, and Productive), student interest, program expertise required and the facilities that are needed.

This study aimed to **map teachers Vocational School (SMK)** throughout Indonesia that can be used to support policy development SMK (70: 30%). This study aims to **map teachers' Vocational High School (SMK)** throughout Indonesia can be used to support policy development SMK (70: 30%). The scope of this study include Vocational Secondary School and the teachers have to regions of **West Sumatra.**, both SMK and private vocational school. Variable of this study include the students, teachers, programs and facilities maintained membership support the learning and teaching (PBM). Variable state study include students, teachers, program expertise and supporting facilities organized learning activities (PBM).

### 3. Results and Discussion

Province of West Sumatra, the potential field of agriculture and trade, hotels & restaurants, it has the Potential for Developing Vocational & industrial technology and business management, it can be developed as the main priority, less than 10% of vocational schools in accordance with spectrum of expertise based on natural resources (SDA) the local area. Therefore, private vocational opportunities open to fill the vacancy, such as Vocational high schools of Agriculture, Hospitality, Business and Vocational Services, food and beverage.

Seeing this condition, it turns out vocational development (both public and private) are not built and developed based on the economic potential of natural resources, but its built upon the scientific disciplines and general industrial development conditions in Indonesia. As we know that Indonesia is trying to be one of the developed industrial regions in this decade. Indications of this

development is the development of SMK is generally located in the capital of the province and city. After the New Order regime ended, the Government Began to build a vocational school to enter the District, although with the same condition and these are dominated by technology and industry expertise and business management.

Data of vocational students in the areas of expertise in each regency / city and new admissions data based on the expertise of the group showed that the most Desirable areas of expertise students are technology and industry and business and management. On the contrary, based on the potential of regional economies, the dominant vocational schools should be the SMK in the field of Farming and Gardening, as well as fisheries. But the expansion of SMK currently still based on the needs and industrial development in Indonesia, which is based on industrial growth. Because this sector requires a lot of job opportunities and easy access to jobs.

School teachers based on data from provinces of West Sumatra, note that the Non-PNS school teachers more than PNS (government employee) teachers. This gives an indication that the shortage of school teachers are still there in the province. Based on education level, more than 90% of teachers already have educational SMK & S1 and D4. The implication of this fact, teacher's education and training need to be improved to a higher education level in the field of vocational education. Based on age groups, it appears the age of teachers in the productive age below 50 years is to achieve 90%.

Comparison of school teachers sex between male and female are relative balanced. But for SMK technology is dominated by male teachers, while that for school teachers and management business is dominated by female teachers. It is generally stated that the school teachers must be increased in number to the PNS and in terms of education for further education to master vocational programs, because their teachers of SMK relatively young age under 50 years.

### 4. Conclusion

This study has been discussed about data and information of vocational high schools in West Sumatera, the data consist of the field of expertise and the spectrum, based on the status of teachers, education, age and gender for all districts / cities in province. School information intended to portray the geographic conditions of the schools including school name, NIS, school address, phone number / fax, name of school principals as well as programs of studies that were implemented in every school. This section provides information to the public on the potential of schools, school location, address, name of the head sekolah with the telephone

number to be contacted, as well as school

Student section is to see the tendency of people's interest in SMK. Using the data of applicants and admitted students SMK, unpredictable people's interest against the SMK. Indicator to detect the amount of data used in the interest of applicants, the numbers of students who recruited the first year and the number of students overall SMK. West Sumatra community has high level of interest to vocational education, while majority of students choice is the field of technology and business expertise.

In West Sumatra, the group of student interest is very high to the field of technology and engineering, followed by a group of fans and business and management, tourism and hospitality industries. Technology and engineering group of studies are the most favorite such as automotive engineering, machining, electrical engineering and information technology as well as electronics and computer-based communications.

School teachers based on the data, publicly stated that the school teachers must be increased in number and quality to the PNS and in education to continue to the master program of vocational education, as most teachers of SMK age of a young relative for more than 90% by age under 50 years.

### IMPLICATIONS

This study provides implications for the development and expansion of SMK in Indonesia. Generally can be stated as follows:

1. SMK expansion is expected based on the economic potential of natural and local resources.
2. Selection of community interest in the membership so far is based on scientific and academic policy. Completion should have been started based on economic potential.
3. SMK current state of teacher shortage across the field (adaptive, normative and productive) affecting the development of competencies and the school.
4. Mapping of Vocational High School are beneficial for the development of regional policies based on knowledge.

accreditation status.

5. Study the suitability of the curriculum with industry conditions and opportunities, current conditions and five years should be implemented.
6. The role of the board of education in supporting the Government policy in the development of vocational education are urgently needed.
7. Local map of the potential benefits of regional (economic) and potential for vocational schools should be updated and upgraded every year.

### RECOMMENDATIONS

1. Proposed to the Government to develop and build SMK based on the potential economies of scale and regional natural resources and economic potential is already there. As SMK hotels, and catering to high-frequency traffic areas loveliest. SMK marine / maritime or SMK Shipping to coastal districts.
2. Enhancing the benefits of SMK socialization to the community, through programs of socialization competency membership, to attract the public more in SMK, especially graduates of junior high school in the district level.
3. Exploiting the potential of existing teachers (SDM) based on educational background, training programs that have followed.
4. Encouraging school teachers to further study vocational master's program, given the age of SMK teachers relatively more young (46%).
5. Increasing Availability of facilities to study, workshop, Labor and relevant library are suitable for SMK.

### REFERENCES

- [1] Law no. Law no. 20 Year 2003 About the National Education System
- [2] Regulation no. 19 Year 2005 About Standard Nasional Education
- [3] Law no. Law no. 14 Year 2005 About Teachers and Lecturers
- [4] Candy No. 22 Year 2006 About Standard Contents
- [5] Candy No. 23 Year 2006 About Standard Approval
- [6] A Delors, " *Learning: The Treasure Within* ", (1997) Unesco, Paris

# STUDY ON PERFORMANCE APPRAISAL METHOD OF VOCATIONAL EDUCATION TEACHERS USING PROMETHEE II

Handaru Jati

Faculty of Engineering, Universitas Negeri Yogyakarta  
handaru@uny.ac.id

## Abstract

Evaluating vocational education teachers' performance is an important link of teaching management and an important guarantee of improving teaching quality. In conducting teaching, research and community service, vocational education teachers should weight more on quality than quantity. In this context, individual habit reacts to the demanded jobs which are influenced by his/her knowledge, attitude, and skill. Teacher's performance evaluation is nothing but a Multi Criteria Decision Making Problem (MCDM). There are several quality attributes that influence the efficiency of a potential vocational education teacher while guiding his/her students towards a positive and value added academic outcome. However, the importance of quality attributes may differ from individuals' perspective. In other words, different attributes may have different weightage according to their priority of significance while evaluating quality/performance level of a vocational education teacher.

This paper makes the vocational education teachers' performance appraisal quantitative and determines the evaluation index based on academic performance. Criteria for performance are: teaching load, publication, research, conferencing, consultancy, services, teaching attitude, teaching content, teaching method, and teaching effect. The Analytic Hierarchy Process (AHP) and PROMETHEE (Preference Ranking Organisation METHod for Enrichment Evaluations) II analysis were used in performance appraisal.

Application feasibility of this method approach and guidelines in solving such a multi-attribute decision making problem has been described illustratively in this paper. It is also observed that this MCDM approach is a viable tool in solving the teacher selection decision problems. It allows the decision maker to rank the candidate alternatives more efficiently and easily.

**Keywords:** performance, teaching, Analytic Hierarchy Process, PROMETHEE II.

---

## 1. Introduction

With the development of higher vocational education and large-scale expansion of enrollment of vocational education institutions and universities, the difficulty in obtaining work and the quality of higher education has aroused extensive attention. The difficult employment of vocational education institution graduates not only has relation with government employment measures, job creating, development of the rhythm of vocational education institution and professional settings, but also, more importantly, has relation with the reform of teaching model and the quality of training. However, the core of solving the problem is how to improve the overall quality of vocational education teachers to improve their core competitiveness. Teacher assessment is an important task. How to establish and improve the performance appraisal system is very important to the development of vocational education institutions, universities and training. However, there are many problems in current performance appraisal of teachers in vocational education institutions and universities, for example: evaluation index system is not sound, the main of assessment is single, so many

qualitative indicators and lack of quantitative assessment, unfair caused by so many subjective evaluation and so forth. These problems have greatly affected the enthusiasm of teachers, which affected to the academic performance. Domestic scholars mostly have theoretical research of performance appraisal of teachers from the point of view of quality, which do not have a strong maneuverability. This paper attempts to use decision analysis approach to compound the qualitative assessment and quantitative assessment to establish a reasonable Teacher Performance Evaluation system to ensure the generalization. The development of an organization is measured from the performance achieved by that organization. Performance achievement of an organization is mainly based on the behavior of human resources within the organization. Organization needs a well-managed structural mechanism in assessing work force performance in correlation to work [1]. Performance appraisal is a measurement conducted on workers to evaluate how they achieve work targets and productivity [2]. Various factors can be regarded in applying performance appraisal. Some researchers state that performance appraisal can be



viewed from various aspects relating to the aims of research or what is going to be analyzed. Some evaluate working activity aspect, while others evaluate behavior or personality aspect.

## 2. Literature Review

The concept of performance was defined differently by a few people. Performance measures must be based on a set of objectives that are linked to the mission of the department and its visions for the future [3]. Pritchard et al. [4] defined performance measures as “the numerical or quantitative indicators that show how well each objective is being met”. Alternatively, Neely et al., [5] defined a performance measure as “a parameter used to quantify the efficiency and / or effectiveness of past action”. In the educational sector, each school of faculty need to establish its core competencies based on its mission and vision, besides thinking of its current resources and state of competitiveness [6].

Decision making for academic staff promotion often involves criteria such as tasks, activities, teaching, supervision, publication, research, consulting, conferencing, administration and community service. Oshabegmi [1] indicated that the main tasks of academic staff can be divided into three categories namely teaching, research and management. Academic staff promotion appraisal is evaluated based on three components such as teaching, research and services. Academic staff appraisal can also be evaluated through items such as research article produced, teaching method, presentation style and involvement in university and community activities [7]. A technique usually used in multi criteria decision making is Analytical Hierarchy Process (AHP) which was introduced by Thomas L. Saaty in 1980. The advantage of using

this technique is in conducting the subjective evaluation situation on the important components or variables in the decision making process. AHP was developed based on three principles which are the principle of constructing hierarchy, the principle of developing priority and the principle of logical consistency [8]. Saaty in his book of *The Analytical Hierarchy Process* developed the hierarchy for the selection of academic staff position and promotion. This hierarchy was developed to make the basic appraisal on the selection based on two main criteria which are teaching and research. However, the criteria became more complicated for a higher level education. At the same time, the application of AHP technique for the purpose of reward and excellent awards at the higher education institution was also formulated at United Arab Emirates University [7]. The model is described in figure 1 and also can be used to evaluate and assess the qualified candidates. The model built is based on three components which are teaching, research and publication, and services. Every component has sub criteria which are related. The analysis indicated that the most important component is research and publication. Preference function based outranking method is a special type of MCDM tool that can provide a ranking ordering of the decision options. The PROMETHEE (preference ranking organization method for enrichment evaluation) method was developed by Brans and Vincke in 1985 [9]. The PROMETHEE I method can provide the partial ordering of the decision alternatives, whereas, PROMETHEE II method can derive the full ranking of the alternatives.

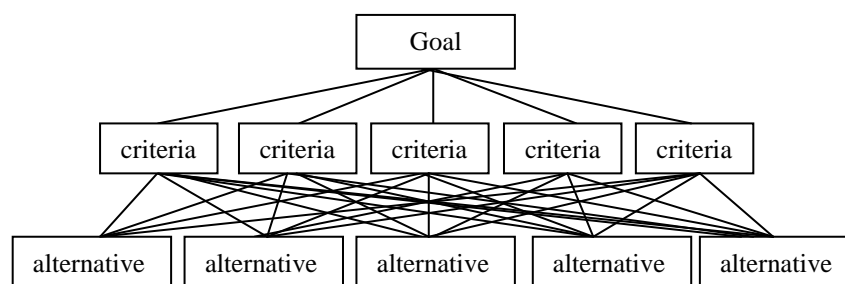

Figure 1. AHP Model of Alternative Performance

## 3. Methodology

This study uses qualitative and quantitative methods to achieve the objectives. Qualitative research in principle focuses on gaining meaning and insight into the area of interest [10]. It is not used to draw any definitive conclusion. It is associated with “face-to-face” contact with people,

together with verbal data and observations [10]. Quantitative method uses techniques that gather measurable data.

The research objectives are as follows: (1) To identify the preferred indicators to measure performance based on teacher perspectives. and (2) To develop a valid and reliable performance

measurement system using AHP and PROMETHEE II to measure teacher performance with regard to teaching, research and servicing that link to strategies.

### 3.1. PROMETHEE II

In this paper, the PROMETHEE II method is employed to obtain the full ranking of the alternative teachers for a given vocational education institution. The procedural steps as involved in PROMETHEE II method are enlisted as below [9]:

Step 1: Normalize the decision matrix using the following equation:

$$R_{ij} = \frac{[X_{ij} - \min(X_{ij})]}{[\max(X_{ij}) - \min(X_{ij})]} \quad (1)$$

$$(i = 1, 2, \dots, n; j = 1, 2, \dots, m)$$

$$R_{ij} = \frac{[\max(X_{ij}) - X_{ij}]}{[\max(X_{ij}) - \min(X_{ij})]} \quad (2)$$

Step 2: Calculate the evaluative differences of  $i^{\text{th}}$  alternative with respect to other alternatives. This step involves the calculation of differences in criteria values between different alternatives pair-wise.

Step 3: Calculate the preference function,  $P_j(i, i')$ . There are mainly six types of generalized preference functions as proposed by [11]. But these preference functions require the definition of some preferential parameters, such as the preference and indifference thresholds. However, in real time applications, it may be difficult for the decision maker to specify which specific form of preference function is suitable for each criterion and also to determine the parameters involved. To avoid this problem, the following simplified preference function is adopted here:

$$P_{ij}(i, i') = 0 \text{ if } R_{ij} < R_{i'j} \quad (3)$$

$$P_{ij}(i, i') = 1 \text{ if } R_{ij} > R_{i'j} \quad (4)$$

Step 4: Calculate the aggregated preference function taking into account the criteria weights.

Aggregated preference function

$$\pi(i, i') = \left[ \sum_{j=1}^m W_j X P_j(i, i') \right] / \sum_{j=1}^m w_j \quad (5)$$

where  $w_j$  is the relative importance (weight) of  $j^{\text{th}}$  criterion.

Step 5: Determine the leaving and entering outranking flows as follows:

Leaving (or positive) flow for  $i^{\text{th}}$  alternative,

$$\phi(i) = \frac{1}{n-1} \sum_{i'=1}^n \pi(i, i') \quad (i \neq i') \quad (6)$$

Entering (or negative) flow for  $i^{\text{th}}$  alternative

$$\phi(i) = \frac{1}{n-1} \sum_{i'=1}^n \pi(i, i') \quad (i \neq i') \quad (7)$$

where  $n$  is the number of alternatives.

Here, each alternative faces  $(n - 1)$  number of other alternatives. The leaving flow expresses how much an alternative dominates the other alternatives, while the entering flow denotes how much an alternative is dominated by the other alternatives. Based on these outranking flows, the PROMETHEE I method can provide a partial preorder of the alternatives, whereas, the PROMETHEE II method can give the complete preorder by using a net flow, though it loses much information of preference relations.

Step 6: Calculate the net outranking flow for each alternative.

$$\phi(i) = \phi^+(i) - \phi^-(i) \quad (8)$$

Step 7: Determine the ranking of all the considered alternatives depending on the values of  $\phi(i)$ . The higher value of  $\phi(i)$ , the better is the alternative. Thus, the best alternative is the one having the highest  $\phi(i)$  value. The PROMETHEE method is an interactive multi-criteria decision-making approach designed to handle quantitative as well as qualitative criteria with discrete alternatives. All qualitative criteria are expressed subjectively in linguistic terms. The objective values for these criteria are assigned from an 5-point scale, as given in Table 1.

Table 1. Fuzzy Scale of Weight Criteria

Weak: W	0.1
Fairly weak: FW	0.3
Average: A	0.5
Fairly high: FH	0.7
High: H	0.9

In this method, pair-wise comparison of the alternatives is performed to compute a preference function for each criterion. Based on this preference function, a preference index for alternative  $i$  over  $i'$  is determined. This preference index is the measure to support the hypothesis that alternative  $i$  is preferred to  $i'$ . The PROMETHEE method has significant advantages over the other MCDM approaches, e.g. multi-attribute utility theory (MAUT) and AHP. The PROMETHEE method can classify the alternatives which are difficult to be compared because of a trade-off relation of evaluation standards as non-comparable alternatives. It is quite different from AHP in that there is no need to perform a pair-wise comparison again when comparative alternatives are added or deleted.

### 3.2. Analytical Hierarchy Process

Analytic Hierarchy Process (AHP) was originally designed to solve complicated multi-criteria decision problem [12], beside that AHP is appropriate whenever a target is obviously declared and a set of relevant criteria and alternatives are offered [13]. AHP has been proposed for study program selection problem to support Higher Education manager through the decision making activity, which aims to select the right Study program to be promoted as International class [14]. The AHP technique assists decision makers to identify and determine the priority of criteria for promoting academic staff [15].

The result is calculated by multiplying the weight of each criterion with the weight of each teacher. The teacher which has got the highest score is suggested as the best teacher and management may consider that one as the best decision choice for promoting academic career. In AHP the problems are usually presented in a hierarchical structure and the decision maker is guided throughout a subsequent series of pairwise comparisons to express the relative strength of the elements in the hierarchy. In general the hierarchy structure encompasses of three levels, where the top level represents the goal, and the lowest level has the teacher under consideration. The intermediate level contains the criteria under which each teacher is evaluated. The final score obtain for each teacher across each criterion is calculated by multiplying the weight of each criterion with the weight of each teacher. Teacher which has got the highest score is suggested as the best teacher and decision maker may consider that one as the best decision choice for promotion.

Generally, AHP has the following steps:

1. Employ a pair-wise comparison approach. Fundamental scale for pair-wise comparisons developed to solve this problem [12]. The pair-wise comparison matrix  $A$ , in which the element  $a_{ij}$  of the matrix is the relative importance of the  $i^{th}$  factor with respect to the  $j^{th}$  factor, could be calculated as  $A = [a_{ij}] = \begin{bmatrix} 1 & a_{12} & \dots & a_{1n} \\ 1/a_{12} & 1 & \dots & a_{2n} \\ \vdots & \vdots & \dots & \vdots \\ 1/a_{1n} & 1/a_{2n} & \dots & 1 \end{bmatrix}$  (9)
2. There are  $n(n-1)/2$  judgments required for developing the set of matrices in step 1. Reciprocals are automatically assigned to each pair-wise comparison, where  $n$  is the matrix size.
3. Hierarchical synthesis is now utilized to weight the eigenvectors according to weights of criteria. The sum is for all weighted

eigenvectors corresponding to those in the next lower hierarchy level.

4. Having made all pair-wise comparisons, consistency is identified by using the eigenvalue  $\lambda_{max}$ , to calculate the consistency index. The largest eigenvalue,  $\lambda_{max}$ , will be

$$\lambda_{max} = \sum_{j=1}^n a_{ij} \frac{W_j}{W_i} \quad (10)$$

where:

$\lambda_{max}$  is the principal or largest eigenvalue of positive real values in a judgment matrix;

$W_j$  is the weight of  $j^{th}$  factor

$W_i$  is the weight of  $i^{th}$  factor.

5. Consistency test. Each pair-wise comparison contains numerous decision elements for the consistency index (CI), which measures the entire consistency judgment for each comparison matrix and the hierarchy structure. CI and consistency ration (CR) is utilized to assess the consistency of the comparison matrix. The CI and CR are defined as

$$CI = \frac{\lambda_{max} - n}{n - 1} \quad (11)$$

where  $n$  is the matrix size.

- 6.

$$CR = \frac{Ci}{Ri} \quad (12)$$

7. where the judgment consistency can be checked by taking the CR of CI with the appropriate value. The CR is acceptable if it does not exceed 0.10. The CR is  $> 0.10$ , the judgment matrix is inconsistent. To acquire a consistent matrix, judgments should be reviewed and improved.

### 4. Illustrative Example

Yan [16] employed the Analytical Hierarchy Process for ranking college teachers' performance appraisal quantitatively and determines the evaluation index qualitatively from teaching attitude, teaching content, teaching method and teaching effect four aspects.

The same example is considered here to demonstrate the applicability and effectiveness of PROMETHEE II method as a MCDM tool. This example takes into account ten selection criteria and three alternative teachers. The objective and subjective information regarding different selection criteria are given in Table 2. All these criteria are expressed subjectively in linguistic terms and numeric value. The objective values for these criteria are assigned from an 5-point scale, as given in Table 2. The fuzzy judgments weak (W), fairly weak (FW), average (A) and fairly high (FH), and

high (H) shown in Table 1 with respect to different criteria. The ten selection criteria as considered here to affect the decision are teaching load (A), publication (B), research (C), conferencing (D),

consultancy (E), services (F), teaching attitude (G), teaching content (H), teaching method (I), and teaching effect (J). and the remaining are the beneficial attributes.

Table 2. Result for teacher performance

	A	B	C	D	E	F	G	H	I	J
Teacher A	14	6	25000	10	3	18	FW	A	H	FW
Teacher B	16	4	50000	6	5	12	A	H	W	FH
Teacher C	20	2	14000	4	6	24	FH	FH	A	H

At first, the information for teacher alternatives with respect to different criteria, as shown in Table 2, are converted to crisp scores using the 5-point scale, as given in Table 3. The transformed objective data, as given in Table 3, are then normalized using Eqn. (1) or (2) and are given in Table 4. Determined the criteria weights for the

considered criteria as  $w_A = 0.1267$ ,  $w_B = 0.1267$ ,  $w_C = 0.0883$ ,  $w_D = 0.0517$ ,  $w_E = 0.0929$ ,  $w_F = 0.0706$ ,  $w_G = 0.0834$ ,  $w_H = 0.0834$ ,  $w_I = 0.1382$ , and  $w_J = 0.1382$  using AHP method and the same criteria weights are used here for PROMETHEE II method-based analysis.

Table 3. Objective data for teacher performance selection problem

Teacher	A	B	C	D	E	F	G	H	I	J	K
Teacher A	14	6	25000	10	3	18	0.3	0.5	0.9	0.3	14
Teacher B	16	4	50000	6	5	12	0.5	0.9	0.1	0.7	16
Teacher C	20	2	14000	4	6	24	0.7	0.7	0.5	0.9	20

Table 4. Normalized decision matrix

Teacher	A	B	C	D	E	F	G	H	I	J	K
Teacher A	1	1	0.306	1	0	0.5	0	0	1	0	1
Teacher B	0.667	0.5	1	0.333	0.667	0	0.5	1	0	0.667	0.667
Teacher C	0	0	0	0	1	1	1	0.5	0.5	1	0

Now, the preference functions are calculated for all the pairs of alternatives, using Eqns. (3) and (4), and are given in Table 5. Table 6 exhibits the aggregated preference function values for all the paired alternatives, as calculated using

Eqn. (5). The leaving and the entering flows for different teacher alternatives are now computed using Eqns. (6) and (7) respectively, and are shown in Table 7.

Table 5. Preference functions for all the pairs of alternatives

	A	B	C	D	E	F	G	H	I	J
(A,B)	0.333	0.5	0	4	0	0.5	0	0	1	0
(A,C)	1	1	0.306	6	0	0	0	0	0.5	0
(B,A)	0	0	0.694	0	2	0	0.5	1	0	0.667
(B,C)	0.667	0.5	1	2	0	0	0	0.5	0	0

Table 6. Aggregated preference function

	teacher A	teacher B	teacher C
teacher A		0.485883	0.659681
teacher B	0.464353		0.381217
teacher C	0.3915	0.258433	

Table 7. Leaving and entering flows for different teachers

Teacher	Leaving flow	Entering flow
teacher A	0.572782	0.427926
teacher B	0.422785	0.372158
teacher C	0.324967	0.520449

Table 8. Net outranking flow values for different teacher (alternatives)

Teacher Performance	Net outranking flow	Rank
teacher A	0.144856	1
teacher B	0.050626	2
teacher C	-0.19548	3

The net outranking flow values for different alternative teachers and their relative rankings are given in Table 8. Now, the alternative teachers are arranged in descending order according to their net outranking flow values. The best teacher performance of vocational education institution is teacher A. This proves the applicability and potentiality of the PROMETHEE II method for solving complex decision-making problems in the academic domain.

### 5. Conclusion

School and university are organizations which based on science which is not overtly competitive. The competitive advantage should lie on academic staffs as the main resource. With behavior appraisal, academic staffs will make the school and university to become more globally competitive as a science-based organization and as the main producer of human capital. The statement correlates with the main function of a vocational education institution as the main producer of human resources which is based on science and competency, and which shows its competitive advantage. Teacher appraisal performance decision has long-term implications. It is therefore important to select the best teacher for a given educational institution. The problem of teacher appraisal performance is a strategic issue and has significant impact on the performance of the vocational education institutions. The present study explores the use of PROMETHEE II method in solving a teacher selection problem and the results obtained can be valuable to the decision maker in framing the teacher selection strategies. It is also observed that this MCDM approach is a viable tool in solving the teacher selection decision problems. It allows the decision maker to rank the candidate alternatives more efficiently and easily. The cited real time vocational education institution example demonstrates the computational process of the PROMETHEE II method and the same method can also be applied to other strategic decision-making problems.

### REFERENCES

[1] [1]. Oshagbemi, T., How satisfied are academics with their primary tasks of teaching, research and administration and management? *International Journal of Sustainability in Higher Education*, 2000. 1(2): p. 124-136.

[2] [2]. Nasution, H. and N.A. Marzuki, *The Analysis of Work Behavior and Work Result towards Work Performance*. *International Journal for Educational Studies*, 2011. 3(2).

[3] [3]. Al-Turki, U. and S. Duffuaa, *Performance measures for academic departments*. *International Journal of Educational Management*, 2003. 17(7): p. 330-338.

[4] [4]. Pritchard, R.D., et al., *Implementing feedback systems to enhance productivity: a practical guide*. *National Productivity Review*, 1990. 10(1): p. 57-67.

[5] [5]. Neely, A., M. Gregory, and K. Platts, *Performance measurement system design: a literature review and research agenda*. *International Journal of Operations & Production Management*, 1995. 15(4): p. 80-116.

[6] [6]. Chen, S.H., C.C. Yang, and J.Y. Shiao, *The application of balanced scorecard in the performance evaluation of higher education*. *The TQM Magazine*, 2006. 18(2): p. 190-205.

[7] [7]. Badri, M.A. and M.H. Abdulla, *Awards of excellence in institutions of higher education: an AHP approach*. *International Journal of Educational Management*, 2004. 18(4): p. 224-242.

[8] [8]. Islam, R. and S.M. Rasad, *Employee Performance Evaluation by the AHP: A Case Study*. *Asia Pacific Management Review*, 2006. 11(3): p. 163.

[9] [9]. Brans, J.P., P. Vincke, and B. Mareschal, *How to select and how to rank projects: The PROMETHEE method*. *European Journal of Operational Research*, 1986. 24(2): p. 228-238.

[10] [10]. Rubin, H.J. and I. Rubin, *Qualitative interviewing: The art of hearing data*. 2005: Sage Publications, Inc.

[11] [11]. Brans, J.P., B. Mareschal, and P. Vincke, *PROMETHEE: A new family of outranking methods in multicriteria analysis*. *Operational Research*, 1984. 84: p. 477-490.

[12] [12]. Saaty, T.L., *The analytic hierarchy process: planning, priority setting, resource allocation*. 1980: McGraw-Hill International Book Co.

[13] [13]. Bayazita, O. and B. Karpakb, *An AHP application in vendor selection*. 2005, ISAHP.

[14] [14]. Jati, H., *DECISION SUPPORT SYSTEM FOR MANAGING AND DETERMINING INTERNATIONAL CLASS PROGRAM: GA AND AHP APPROACH*. *JOURNAL OF EDUCATION*, 2011. 3.

[15] [15]. Salmuni, W., W. Mustaffa, and K. Hariri. *Prioritizing academic staff performance criteria in higher education institutions to global standards*. 2007.

[16] [16]. Yan, L. and Z. Fan. *Study on Performance Appraisal Method of College Teachers*. 2009: IEEE.

# CATCHING UP WITH THE TECHNOLOGICAL PROGRESS IN THE SURVEYING AND MAPPING WORKPLACE BY INTENSIFYING SCHOOL-INDUSTRY PARTNERSHIPS

Sunar Rochmadi

Department of Civil and Planning Engineering, Faculty of Engineering, Yogyakarta State University  
srochmadi@yahoo.com

## Abstract

The surveying and mapping workplace experiences rapid changes of technology, with the emergence of electronic total station (ETS) and global positioning system (GPS) triggered by electronic and digital technologies. This has caused vocational secondary schools find difficulties in catching up with such progresses. Purchasing new equipments being out of date after a few years is too expensive for schools, so it needs other alternatives to overcome this challenge. Based on the effectiveness and efficiency reasons, industries tend to be more advance in technology updating, leaving vocational schools behind. Intensifying partnerships between school and industry can meet this challenge of technological progresses.

Currently school-industry partnerships are usually limited to two typical activities, industrial work practice or internship and competency test. There are really various activities could be proposed by such partnerships, covering the student learning processes, apprenticeships for after-graduated, and externships for enhancing teachers' competencies. The activities on the students' learning can be guest speakers from industry, industry visits by students, industrial practice orientations involving practitioners, and demonstrations of up-to-date equipments by industry. Such partnership activities can only succeed if there are mutual benefits for school and industry. The industry benefits from the availability of competent workers and the school's main benefit is the more relevant learning program to meet the requirements of the world of work.

**Keywords:** changes of technology, vocational education, surveying and mapping, school-industry partnerships.

---

## 1. Introduction

The surveying and mapping workplace experiences rapid changes of technology, with the emergence of electronic total station (ETS) and global positioning system (GPS) triggered by electronic and digital technologies. This has caused vocational secondary schools preparing workforces for this field find difficulties in catching up with such progresses. Purchasing new equipments being out of date after a few years is too expensive for schools, so it needs other alternatives to overcome this challenge.

Surveying and mapping works are needed for all infrastructure planning and construction. These works are conducted by at least three levels of workers, namely engineer, technician, and operator. There is a lack of workforce of the operator level, although there have been 47 vocational secondary schools (VSSs) running the surveying and mapping program all over Indonesia. This could be caused by a gap between the school graduate competencies and the requirements of the surveying and mapping industries. The lack of up-to-date equipments to some extent contributes to this gap. Based on the effectiveness and efficiency reasons, industries tend to be more advance in technology updating, leaving vocational schools behind. To bridge this gap, learning applied by the surveying and mapping

program should be developed responsive to the needs of the world of work.

The surveying and mapping program of the VSSs is designed to produce surveying and mapping workers at the operator level. The surveying and mapping or geomatics expertise group of the national vocational education chamber has set geomatics competency standard including competency standard of surveying sector for the operator level. Based on this standard, the Ministry of Workforce has produced a regulation of the Indonesian National Work Competency Standard for Consultancy Industry Service sector, Surveying and Mapping subsector. To achieve this standard, the Ministry of National Education has established the competency standard and basic competency to be applied in the learning process of the VSSs including the surveying and mapping program. To support this program, electronic school books including the surveying and mapping field have actually been published. The learning process in the schools, however, still faces many difficulties to provide graduates meeting the requirements of the world of work. The learning outcomes have not adequately responded those needs

Learning responsive to the needs of the world of work could be achieved by involvement of the industry in the students learning processes. The world of work of surveying and mapping may be in governmental or private institutions. Governmental

institutions which need surveying and mapping works are such as institutions managing public work, land administration, land and building taxes, mining, agriculture, forestry, and defense. Such institutions generally order relatively larger work volumes to private companies, so there are only small numbers of permanent workers needed. Private companies of surveying and mapping also rarely have large number of permanent workers, because many workers are recruited from free lance workers when they get work orders. Relatively high worker mobility leads to a constraint for involvement of surveying and mapping world of work in the learning process. Most of surveying and mapping workers, of engineer, technician, or operator levels, are not tightened to particular companies. They are recruited by companies getting surveying and mapping jobs. Another problem is relatively long distances from schools to the world of work. Moreover, the distances from the offices, governmental or private, to the work sites may or even often too far, on different provinces or even different islands.

## 2. Technological Progresses in the Surveying and Mapping Workplace

Accelerated technological progresses make it more essential for education institutions to respond the ever-changing needs of the world of work. The land surveying and mapping works are conducted using surveying equipments that can be optical or electronic. The technological progress of the surveying equipments tends to be more electronic or digital. The digital surveying equipments include: Electronic Distance Measurement (EDM), Electronic Total Station (ETS), digital theodolite and digital level. Digital surveying instruments benefit such as quicker operation and less human errors such as estimating and reading errors.

Since the development of computer technology, in surveying and mapping activities the terms “geoinformatics” and “geomatics” emerge. Both terms are used in the developed countries such as America, Europe, and Australia, since the 1990s. Data acquisition techniques are developed from terrestrial surveying to remote sensing by utilization of aircraft and spacecraft platforms. The positioning technique is developed from optical, optical-electronic, electronic, and finally digital, from land-based measurement to space-based measurement such as Global Positioning System (GPS) satellites. The knowledge of geomatics consists of not only data acquisition, but also geographic (spatial) information system development and spatial data modeling to develop decision support system for various planning works. There is a shift on human resource education from surveying techniques to geomatics techniques. Geomatics profession previously named surveyor or land surveyor or mapping surveyor changes to geomatics surveyor.

Surveying and mapping works can be divided into three steps: data collection step, data and information processing step, and data and information presentation. Technological development in the data acquisition step is marked by more widely used electronic and digital instruments, and satellite technologies for positioning and digitally recording earth surface images. In terrestrial surveys, conventional (optical) instruments such as theodolite and level shift to electronic such as digital theodolite, digital level, and electronic total station (Figure 1). Extra-terrestrial surveys using satellites such as GPS are more widely used with higher accuracy especially for horizontal position (Figure 2). Remote sensing with higher resolution replaces terrestrial and photogrammetric detail surveying.

Technological development in the data processing step is marked by more widely used computer softwares such as spreadsheets for surveying data calculation, GPS data processing softwares, and digital image processing softwares. The data and information step develops to digital formats using computer softwares such as Computer Aided Drafting (CAD) for drawing maps or land profiles, printer for map printing, and presentation using Geographic Information System (GIS) softwares.



Figure 1. Surveying using Electronic Total Station (courtesy of CV Putra Mandiri)



Figure 2. Surveying using GPS (courtesy of CV Putra Mandiri)

In the competency standard and basic competency applied for the surveying and mapping program in the VSSs, there is no explicit content of the newest technologies to response the technological progress, except for GPS. The more developed countries, such as Australia and the United States of America, on the other hand, explicitly address this progress in their curriculum. In Australia [1], the uses of newest technologies are explicitly accommodated in the curriculum of surveying and mapping education and training programs. In the Certificate program (475 hours) about 40% of the whole time allocation, the modules or units referred to technological development are explicitly included in the curriculum: Perform basic spatial computations (100 hours), Operate computer packages (25 hours), Develop and use complex spreadsheet (30 hours), and Prepare and present Geographic Information Systems Data (36 hours). In the Diploma program (1400 hours), the modules/units explicitly referred to technological development are placed about 32% of the time allocation: Perform advanced GPS data collection (40 hours), Manage advance surveying computation (80 hours), Develop complex spreadsheet (30 hours), Design spatial data storage systems (60 hours), Present GIS data (36 hours), Data analysis with GIS (36 hours), and Develop two-dimension and three-dimension terrain visualization (160 hours). In the United States, the curriculum of the Surveying and Mapping Technology program [2] also lists explicitly the newest technologies: Conduct electronic distance measurement, Use GPS, and Conduct Computer Assisted Drafting (CAD) drawing.

The problem of keeping pace with technological advance does not only take place in the developing countries, but also in the more advanced ones. Maintaining the currency of knowledge and equipment within public technical institutions in the United States, Germany and Australia appears to be common difficulties [3]. Maintaining up-to-date equipments is very costly and they become quickly redundant. Every three to five years, the equipment becomes obsolete as new technology emerges, so the equipment needs to be replaced [4].

The more advance technologies promise more effective and more efficient works. Therefore based on the effectiveness and efficiency reasons, industries tend to be more advance in technology updating, leaving vocational schools behind. The schools therefore need to approach to industries for sharing their resources. This can be attempted only by a closer relationship between school and industries, therefore more learning activities can be implemented. Intensifying partnerships between school and industry may meet this challenge of technological progresses.

### 3. Current School-Industry Partnership

Currently the students learning processes in the vocational secondary schools conducted by the involvement of the world of work or based on school-industry partnerships are generally limited to two typical activities, the Industrial Work Practice (IWP) and competency test. Both IWP and competency test are only once experienced by students during their study in the VSS (Figure 3). In IWP, students learn in the world of work guided by the practitioners of the industry and the guiding teachers. IWP usually lasts for three months, while the industries usually require six months if they are asked to contribute in funding the activities. In the competency test, industry practitioners act as one of the assessors as external testers. As the nature of surveying and mapping industries, the participating world of work could be governmental or private institutions. The governmental institution that participates most is the National Land Agency, because of its relatively well geographic distribution, exists in every district/city. However, the competencies which can be learned there are very limited, they have not covered all competencies set in the competency standard and basic competency. IWP in a private company faces problem whether such company gets a job order or not. Moreover, the characteristic of the job is temporary, not well distributed along the year, and it is not always matched with the school schedule.

One problem of the involvement of the world of work in student learning is the industries tend to get ready-to-work graduates only, so they will not need to train them. Even students who are going to have IWP are required to be ready-to-work also. In fact, students often meet equipments they have not learned before, so they are considered as not competence by industry practitioners. The students therefore need an early orientation to the world of work before they have IWP. Another problem is the locations of the world of work that are often in long distances from the school. In order to be able to establish learning that is responsive to the needs of the world of work, those problems need to be solved, so the involvement of the world of work in learning can be conducted.

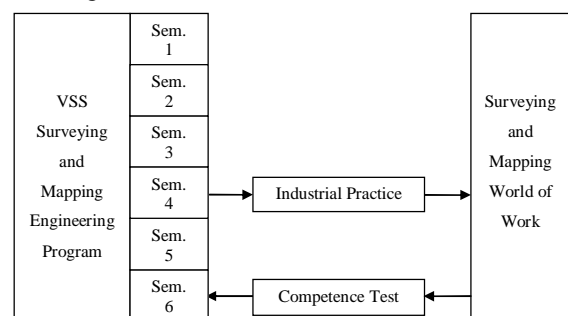

Figure 3. Current Partnership of Students Learning



#### 4. Activities of School-Industry Partnerships

School-industry partnerships give various opportunities to improve the students learning processes. Various identified activities [5] could be implemented in vocational education and industry cooperation: career day, school advisory committee, job analysis by teachers, personal contact to persons from the world of work, cooperative work experience program, vocational training for teachers by holiday session work, school program publication and information for the world of work, partnership of teachers and the world of work, students' productive activities sponsored by industries for educational purposes, industry persons as source persons (consultant, speaker) in school, survey of the world of work by teachers, such as: job, equipments, and needs assessment survey, teachers act as consultants of the world of work, such as in worker training, work system and procedure, the world of work sponsors learning materials, equipments of the world of work displayed in school, and continuing education program, such as short course, workshop, training or retraining for workers or worker-candidates.

The role of the world of work in school advisory committee is very important [6]. The school advisory committee may consist of the world of work, union, local government, public service agency, and graduate user elements. The cooperation links between school and the world of work are important and teachers should have self-confidence and be admired viewed by their related people of the world of work. Therefore, teachers should periodically renew their skills, learn new practices, and keep in touch with the world of work. Various identified roles of the world of work are such as: introduce students to the real work situation, workers as temporary instructors in school, training in the workplace, link theories and the real practices, feedback from the world of work for education programs to revise and improve the programs, apprenticeships, dual system education, and graduate placement [6].

Considering the very essential roles of the world of work, developing closer partnerships between schools and the world of work is absolutely needed. From the above description it could be concluded that the success of the education program in VSSs is very determined by the partnerships between school and the world of work. By this partnership, schools can respond the needs of the world of work by developing learning practices relevant to those needs.

Although other than the surveying and mapping field, many researches of the partnerships between schools and businesses have been reported, such as the mutual benefits when information technology (IT) companies partner with high schools [8], i.e. the students get the necessary career training for future success and the companies

get a skilled workforce for the future. The partnerships between high schools and private high-tech companies prove to be one way to ensure that students learn skills relevant to current workplace. Three examples of high school-company partnerships working together to train future technical workforce are concluded: a local entrepreneur helps students gain skills and serve community, a training company teaches students marketable skills, and a local training company puts faith in high school students.

Another report observing the automotive industries highlights the need of partnership of schools and industries to keep up the flood of new technology [9]. This quick technological change may swamp both schools and businesses if they do not work together to prepare technicians for the new world of auto service and repair. The listed barriers of updating technology in schools, i.e. the limited schools' budget to purchase new equipments, the instructors' lack of training needed to have industry's credibility, and the lack of administrators' and guidance counselors' recognition to the needs of updated skills. Based on the survey of four automotive technology programs, a high school, a vocational center, a secondary-postsecondary vocational-technical center, and community college, the listed ways to overcome the obstacles, i.e.: (1) rapid technology advances require students master not only specific technical skills but also the academic and thinking skills for continuous learning, (2) a program cannot survive merely on money from the district or institution, so instructors must be creative in finding funding or donations, (3) instructors must establish partnerships with industries to keep current with needs, provide on-the-job experience for students and gain access to resources, (4) to get funding from public and corporate sources, a program must prove itself, beginning with certification for instructors and certification for such program, and (5) because schools need up-to-date equipments and the industries need good training programs for future and current technicians, the two should share resources.

Vocational teachers may use external and internal sources to keep up new technologies [3]. The most commonly used and important external sources are leading-edge private users or producers/suppliers of advanced technology, industry associations, and time spent with the learners themselves and in plants. The most commonly cited and important internal sources are websites and journal circulation. Sharing information and networking with other colleges and undertaking professional development are also important.

Regarding the partnership between schools and industries, various activities are listed [7], such as participating companies as advisory board

members, helping schools to develop internships within their firms and others, planning events and activities for students, providing direct financial assistance, securing financial assistance, providing advice on curriculum and program design, and serving as an advocate of the program to the school district. Furthermore the majority of industries also provide other learning experiences for students, including mentoring, workplace tours and job shadowing.

The partnerships of schools and industries obviously benefit schools [7], such as the employers provide funding for program administration, a student conference, overnight job shadows and an auction, the employer partners review the curriculum annually, provide internships and offer mock interviews for students to practice their skills. Such employer involvement impacts teachers' work. Approximately half the teachers surveyed had participated in formal employer-sponsored professional development, such as job shadowing, having an internship, or consulting with employers on course content. An employer-teacher mentorship program was initiated, in order to facilitate communication between school staff and the business world. This allowed teachers, many of whom have no business experience, to bridge the gap between school and the business world. Students also benefited from employer involvement, beyond their workplace learning experiences. The employers serve as a source of adult support and as role models. Most students who had paid summer internships through the academy program said that they had discussed possible careers with their employer. They also agreed that someone in the business took an interest in them. Over half said that their academy summer internship or an academy mentor were significant influences in their future career direction. Finally, and perhaps most significantly, 40% of the alumni surveyed said that, the fall after high school graduation, they held a job with a NAF-affiliated employer.

How such partnerships benefit the industries is also proven [7]. The employers have both philanthropic and individual reasons for participating. Their most important motivation for participating tends to the philanthropic response, i.e. contributing to education and the local community. The second most frequent reason is increasing organization's positive image in the community. The other less stated reasons are encouragement from other employers, shortage of employees, networking with other firms and building a client base.

### **5. Intensifying School-Industry Partnership**

There are really various activities based on school-industry partnerships could be implemented, covering the student learning processes,

apprenticeships for after-graduated, and externships for enhancing teachers' competencies. The activities on the students' learning can be guest speakers from industry, industry visits by students, industrial practice orientations involving practitioners, and demonstrations of up-to-date equipments by industry. Industry practitioners as guest speakers may give the students an overview of the world of work especially current technologies and equipments applied there. Students visit to industry provides a great opportunity for them to explore what is really going there, especially the emerging technologies applied in the world of work. Industrial work practice orientation by industry practitioners can equip the students with the more current knowledge directly informed by industry persons. Demonstration of up-to-date equipments by industry practitioners could minimize the strange feeling of students toward new technologies.

The students learning processes involving the world of work to provide students familiar with new technologies will not succeed unless being supported by the teacher's experience in the real world of work. The teachers themselves should have sufficient experience with such up-to-date technologies. A program called externship is needed to equip teachers with such experience. By externship program, the teachers gain industrial experiences by working in industry for a certain period of time.

Although many activities have been conducted during their study in VSS, due to the dynamic nature of the world of work, the graduated students may need to supplement and enrich their experiences by an apprenticeship program after their graduation. Those various students learning activities, supplemented by after-graduation apprenticeship program, hopefully will make the process of providing new workforces entering the world of work with ever-changing technologies smoother.

Such partnership activities described above can only succeed if there are mutual benefits for school and industry. The industry can get the benefits mainly from the availability of competent workers therefore it will minimize the training cost of the new employees. The school's main benefit is the more relevant learning program to meet the requirements of the world of work.

The two typical activities of students learning processes involving the world of work are the Industrial Work Practice (IWP) and competency test. IWP is usually conducted at the fourth semester and the competency test at the final semester. Therefore, the students currently get learning processes with the involvement of the world of work only at two, of their six semesters. As a result there are still four semesters students have learning processes without the involvement of

the world of work. As an alternative to optimize learning by intensifying school-industry partnerships, some learning forms could be developed, such as: (1) practitioners as guest teachers from the world of work visit the schools to teach students, could be conducted at semester one, (2) students learn by visiting the world the work, could be at semester two, (3) practitioners from the world of work deliver IWP orientation, could be at semester three, and (4) instructors from the world of work bring and demonstrate up-to-date equipments to students, could be at semester five (Figure 4). An illustration of the documented photographs of the surveying and mapping VSS students visit to the world of work is displayed on Figure 5.

Considering the various sectors of industries employing surveying and mapping workers, the

industries involved in the students learning could be assigned varied, from different sectors for different activities, such as land administration, public work, mining, agro-forestry, and defense. Besides leading to get more familiar with up-to-date equipments, learning with the involvement of the world of work hopefully lead to student achievement of competencies currently less mastered, such as work attitude and ethic, and professional responsibility. The work attitude includes attitude towards local labors, equipments, and data of surveying and mapping. On data collecting step, there is a difference between practice in school and the real work. In school practice, a student is assisted by other students, while in the world of work a surveyor is assisted by some local labors recruited from the work site surrounding.

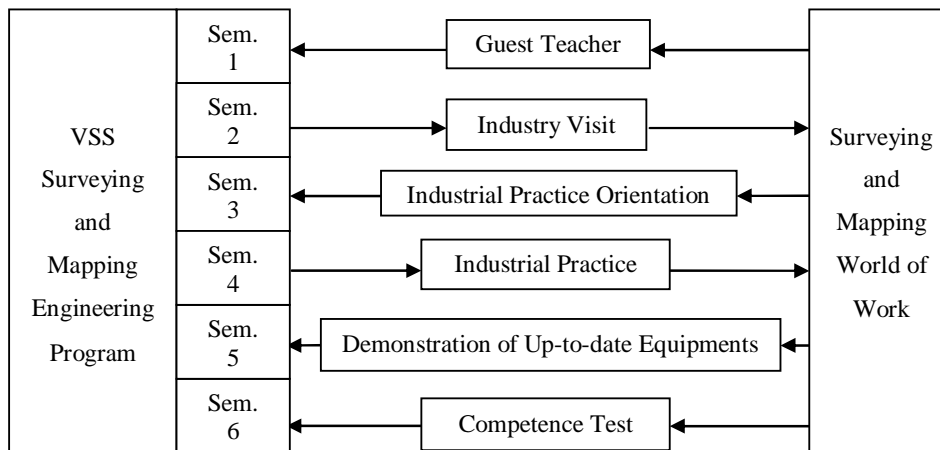

Figure 4. Students Learning Activities Based on Intensified School-Industry Partnerships



Figure 5. VSS Students Visit to the World of Work (courtesy of SMKN 2 Yogyakarta)

## 6. Conclusion

The surveying and mapping workplace experiences rapid changes of technology, such as the emergence of electronic total station (ETS) and global positioning system (GPS) triggered by electronic and digital technologies. This has caused vocational secondary schools find difficulties in

catching up with such progresses. Purchasing new equipments being out of date after a few years is too expensive for schools, so it needs other alternatives to overcome this challenge. Based on the effectiveness and efficiency reasons, industries tend to be more advance in technology updating, leaving vocational schools behind. Intensifying partnerships between school and industry can meet this challenge of technological progresses.

Currently the students learning processes conducted based on school-industry partnerships are usually limited to two typical activities, industrial work practice or internship and competency test. There are really various activities could be proposed by such partnerships, covering the student learning processes, apprenticeships for after-graduated, and externships for enhancing teachers' competencies. The activities on the students' learning can be guest speakers from industry, industry visits by students, industrial practice orientations involving practitioners, and demonstrations of up-to-date equipments by industry. Such partnership activities can only succeed if there are mutual benefits for school and

industry. The industry benefits from the availability of competent workers and the school's main benefit is the more relevant learning program to meet the requirements of the world of work.

#### ACKNOWLEDGMENT

Special thanks to everyone who facilitates and supports the writer to study in the Technology and Vocational Education Doctorate Program, Yogyakarta State University, and to participate in the Sandwich-Like Program in Ohio State University, USA, that has enriched the writer's academic vision.

#### REFERENCES

- [1] TAFE NSW, Modules and Course. New South Wales Department of Education and Training. Downloaded on March 13th, 2009, from <http://www.tafensw.edu.au>.
- [2] Florida Department of Education, Curriculum Framework: Surveying and Mapping Technology. Downloaded on August 14th, 2009 from [www.flboe.org/workforce/dwdframe](http://www.flboe.org/workforce/dwdframe).
- [3] P. Toner, Keeping up with Technology: A pilot study of TAFE and the manufacturing sector. Adelaide: National Center for Vocational Education Research (NCVER), 2005.
- [4] D.C. Brown. "Foresight in Surveying Education." ACSM Bulletin, No.239, June 2009, pp.55-57.
- [5] C.C. Calhoun and A.V. Finch, Vocational Education: Concepts and Operations, Second Edition. Belmont, California: Wadsworth Publishing Company, 1982.
- [6] R.C. Wenrich, J. W. Wenrich and J. D. Galloway, Administration of Vocational Education. Homewood, Illinois: American Technical Publishers, Inc, 1988.
- [7] K.L. Hughes, M.M. Karp and M.T. Orr, "Business partnerships for American education': employer involvement in the national academy foundation's high school career academies', Journal of Vocational Education & Training, 2002, 54: 3, pp.365-394.
- [8] P. Brotherton, Phaedra, "Winning Partnerships." Techniques: Connecting Education & Careers, 15271803, Apr.2001, Vol. 76, Issue 4.
- [9] C. Mulford, "Spotlight on technology." Vocational Education Journal, 08848009, Oct.1994, Vol. 69, Issue 7.

# DEVELOPMENT OF STUDENTS' METACOGNITION AT THE INDUSTRIAL ELECTRONICS VOCATIONAL PROGRAM IN VOCATIONAL HIGH SCHOOLS

Purnamawati

Universitas Negeri Makassar  
tari\_purnamawati@yahoo.com

## Abstract

The purposes of this study are: developing students' metacognition in Industrial Electronics Vocational Program (IEVP) in Vocational High School that satisfy the criteria for valid, effective, and practical. The procedure of development of students' metacognition in IEVP, through four stages, which consist of: (1) initial investigation stage, (2) the design stage, (3) the realization stage, and (d) stage of testing, evaluation, and revision. The results show the following development. First, the development of students' metacognition in IEVP can be done by training the students' skills through: (1) Self-regulation learner, (2) the ability to think, and (3) self study. Before being used in learning, this development must be tested, namely (1) individual trials and (2) small group trials. But the results of field trials on the development of students' metacognition IEVP is not satisfy the criteria of practicality and effectiveness. Therefore, the development of IEVP students' metacognition requires revision in the terms: component syntax (combining phase III and phase IV). Second, the researcher recommends to the researcher in education who wishes to follow up this study for: (1) carry out the implementation, utilization, and empowerment of students' metacognitive, both in learning and in solving problem, (2) empowerment through integrating the components of metacognitive in each IEVP instructional package, (3) the scope of this study is limited to learning the IEVP in VHS. It is therefore advisable to research the field of vocational education for advanced research with learning approaches, learning materials, and levels of education (classes) are different, to increase the repertoire of knowledge, especially the implementation, utilization, and empowerment of cognitive function and metacognitive of students both in learning and in solving problem.

**Keywords:** *Development, Industrial Electronics Vocational Program, Students' Metacognition, Vocational High School*

---

## 1. INTRODUCTION

Development of science and technology in the current globalization era, requires qualified human resources and able to compete with other nations. In addition, the education required responding more quickly and accurately to changes that are taking place in society. Therefore, education becomes increasingly important in accordance with the demands of globalization, improving the quality of human life, and ensuring social, technology, and economics development.

Efforts to deal with these changes, actually requires educational institutions to produce graduates who can compete, adaptive, and anticipatory of the various changes. Pardjono (2003:25) states that for educational institutions still exist in the face of change, especially the structure of employment, the graduates are required to have communication skills, interpersonal, leadership, team working, analysis, academic discipline, understanding about globalization, well trained and ethics, as well as having foreign language proficiency. On the other hand, in the globalization era that characterized by a tendency of increasing complexity of technology equipment, and the emergence of corporative restructuring movement

that emphasizes a combination of technology and human qualities. It causing the world of work will require the humans who can take the initiative, critical thinking, creative, and proficient in solve the problem (Waras Kamdi, 2008:4). Therefore, the relations "man-machine" is not longer a mechanistic relationship, but of a communicative interaction that require higher order thinking skills.

This trend began to respond to the world of education in Indonesia. It is characterized by the implementation of four educational approaches, namely: (1) life skills-oriented education, (2) curriculum and competency-based learning, (3) production-based learning, and (4) broad-based education. The new orientation of education, making educational institutions as life skills educational institutions that aimed at achieving competence. In addition, authentic and contextual learning processes to produce products that are valuable and meaningful, as well as a broad-based education service delivery through various channels and levels of education that are flexible multi-entry multi-exit (Depdiknas, 2002-2003).

Qiuye, *et al.* (2008) suggested that graduate education does not only need to learn, but also need to

know how to learn that effective and efficient, especially in learning lab. Therefore, the concept of metacognition is revised for use in electric power system experiment. As a result metacognition will accelerate the efficiency of learning, especially in learning lab. The combination of improvements and innovations based on the use of metacognition learning practices is one solution to solve the problem. The results of Qiuye, et al.'s study found that metacognitive strategy in experimental units and how strategies can be adopted to improve the effectiveness of learning. The study was carried out repeatedly about the metacognitive aspects in lab learning of electrical engineering. Thus, meta-cognitive learning is very important in practice in electrical engineering in producing graduates who are able to learn independently to improve the ability (competency standards that must be mastered).

The results of Billett's (1994:29) study show that the frequency of various categories of knowledge needed by workers in various types of broad and consistent work. In addition, the nature of the learning experience is provided in the workplace were reported as consistent. Furthermore, it was found that procedural knowledge, the most frequently used (59%, 62%), followed by propositional knowledge (18%, 8%), and dispositional knowledge (conditional) (23%, 30%) is quite interesting. These results demonstrate the importance of metacognitive knowledge in carrying out the work in the world of business and industry. Thus, the learning activities of expertise field on vocational education need metacognitive knowledge in carrying out good employment practices.

Based on the background and problem identification, the problem formulated in this study, namely: "How to develop students' metacognition through the learning of industrial electronics vocational program in Vocational High Schools (VHS) that meet the criteria of validity, practicality, and effectiveness?"

## 2. RESEARCH METHOD

Procedure development of metacognition students through the learning consists of two main stages, namely pre-development phase (research phase) and the development stage (development stage). Phases of pre-development stage include: the initial investigation, design, and realization/construction. Initial investigation phase is the phase of the investigation and information gathering, particularly relating to the field of industrial electronics expertise. Based on the results of the initial investigation, then set/selected methods of learning, metacognition students to design development, design assessment criteria (rubric), and guidelines for development and learning tools (design phase). Furthermore, the phase of realization of the structured development of metacognition students through the learning, assessment criteria (rubric), guidelines for student metacognition and learning

tools are developed. In the conceptual phase of validation is done by an expert (expert judgment) and vocational education practitioners about the feasibility of developing a prototype that has been prepared student metacognition.

The procedure of students' metacognition development through learning is consists of two main stages, namely pre-development stage (research phase) and the development stage. Phases of pre-development stage include: an initial investigation, design, and realization/construction. Initial investigation phase is the phase of investigation and information gathering, particularly relating for the IEVP. Based on the results of initial investigation, then set/selected the methods of learning, design the development of students' metacognition, design assessment criteria (rubric), and guidelines for development and its instructional package (design phase). Furthermore, in the realization phase, the researcher arranged the development of students' metacognition through instructional package, assessment criteria (rubric), guidelines for students' metacognition and instructional package that are developed. In this phase, an expert (expert judgments) and vocational education practitioners do the validation about the feasibility of prototype of students' metacognition development that has been prepared.

The main activities at development stage are related to test, evaluation and revision phase. This phase focused on the activities of field trials (empirical validation) of the prototype development of students' metacognition, as a follow-up of the conceptual validation by experts and education practitioners. In this stage, it is expected to obtain empirical evidence that the development of student's metacognition have met the criteria developed by a valid, practical, and effective. To this end, it will be pursued the steps at this stage include individual trials and small group trials.

The subject of the trials is consists of: (1) vocational students and (2) teachers' in industrial electronics vocational program. While, the data that obtained in this study is quantitative and qualitative data. The data are obtained based on the results of the test: validity, practicality, and effectiveness of students' metacognition for IEVP through instructional package.

Instruments as a data-gathering tool are intended to measure the validity, practicality, and effectiveness of the development of students' metacognition in the instructional package. The validity of the students' metacognition development uses the instrument of validation sheet. The practicality of of the students' metacognition development uses the instrument of observation sheet. Observation sheet in question is the observation sheet about feasibility of students' metacognition through the instructional package. The effectiveness of students' metacognition through the

instructional package use the instruments: (1) observation sheet of students' activities in learning, (2) observation sheet of teacher's ability in managing learning, (3) questionnaire of students' response to the components and learning activities. Before use, these instruments are assessed/validated by the 6 (six) validator experts & practitioners of electronic engineering education, which consists of: 3 (three) lectures and 3 (three) practitioner (teachers).

### **3. RESULTS AND DISCUSSION**

#### **3.1 Results that obtained in this study**

##### **3.1.1 Investigation Phase**

First, the instructional packages that are used in the IEVP today are prepared on KTSP 2006 curriculum that outlined in the syllabus. This system is passive. It is shown by the dependence of students on the material/jobsheet from teacher, so that there will be stagnation in scientific development.

Second, the teachers have not made innovations in learning by including some important additional components, such as question-answer and discussion or test the initial capability of students on jobsheet that will be practiced. Teachers are less well monitored the learning process, so that the feedback between teacher-student less conducting.

Third, the results of discussions with some industrial electronics teachers at some vocational high school in the Makassar city about learning lab conditions, obtained the results: (1) schools have been using KTSP 2006 and the spectrum of secondary vocational education skills, but the process is still teacher-centered learning and occasional use of cooperative learning (adapted to the material). All information about the learning concepts are described by the teacher, except for some problems that prompted the teacher to be done by students, (2) there is no instructional package that used by teachers to develop students' metacognition skills. Learning is still using a conventional yet well structured. As a result, the learning is done without good planning, (3) students' handbook that is used is a book on the market, according to the wishes of teachers. Thus, teachers and students just follow the sequence of materials (teaching materials) and measures such as the author desires, (4) tasks in general continues to be routine, that is only in the form of working on the problem, so the lack of training students to use knowledge and skills metacognitive in solving problems and constructing; (5) giving feedback is rarely done by the teachers so that students are less motivated to learn themselves and do exercises when not assigned by the teacher, (6) the ways to evaluate learning outcomes dominant emphasis on the mastery of the material substance.

##### **3.1.2 Design Phase**

First, the design of the development of students' metacognition through the instructional package (DSMIP) is to establish format guidelines. The format guidelines DSMIP are contained steps and guide the implementation of the development of students' metacognition through the instructional package. Introduction contains things that become the main consideration DSMIP. DSMIP contains 5 (five) main components: syntax, social system, principles of reaction, support system, and the instructional & accompaniment impact. While, DSMIP guidelines contain things such as: the tasks of planning, organizing classes, helping students' activities, handle the situation individually/group learning.

Second, the design of instructional package, namely: lesson plan, lab guides, teaching materials microprocessor, and jobsheet. While, design of instruments: validation sheet, observation sheets of teacher's ability in managing learning, observation sheet of students' activities, and questionnaire of students' responses towards learning to use DSMIP.

##### **3.1.3 Realization Phase**

Based on the results of the investigation phase and design phase, and then reflected and examined again to be directed to the development/realization of a prototype, namely: (1) the guidelines of development of students' metacognition through the instructional package, and (2) instruments.

##### **3.1.4 Test/Evaluation/Revision Phase**

Test/evaluation/revision phase is obtained: (1) the validation results, (2) the result of experts & practitioners assessment toward feasibility and effectiveness of the development of students' metacognition through the instructional package, and (3) the results of field trials.

a. Validation results of the development of students' metacognition through the instructional package, and Instruments.

DSMIP validity, and the instrument was rated by 6 (six) validators. Generally, the validator gives value or directly notes on DSMIP, and instruments. Based on the results of data analysis found DSMIP guidelines and its instruments declared valid with minor revisions.

b. Feasibility and effectiveness DSMIP

One way to determine feasibility and effectiveness is through the assessment of experts & practitioners who state that DSMIP can be used in the learning process. Assessment results feasibility and effectiveness DSMIP, are: (1) Feasibility DSMIP, assessment results of feasibility concluded that DSMIP can be carried out in the learning process. Therefore, in theory DSMIP meet the criteria of practicality, and (2) effectiveness DSMIP, assessment results of feasibility DSMIP is

effective to implement. Therefore, in theory DSMIP meet effectiveness criteria.

c. Field trials

Field trials aim to know that the real DSMIP field meets the criteria of practicality and effectiveness. But the test in this study is limited in individual trials and testing a small group on SMK Negeri 5 Makassar. Description of data analysis based on the implementation of the trial is as follows.

(1) Description of practicality DSMIP

Practicality (Feasibility) is shown by the ability of teachers to manage learning. The ability of teachers to manage learning for every aspect that is observed is as follows.

Components of the syntax, the first five meetings there are several stages in the syntax is not performing well, because the teacher is less good or less than perfect in its execution. The observation of feasibility DSMIP syntax component to each meeting, are: Stage I performing well; stage II performing well; stage III at the first meeting and the second less than perfect implementation; stage IV at the first meeting, second, third and less than perfect implementation; stage V performing well; and stage VI of performing well.

Components of the social system, the first five meetings there are aspects in the social system is not performing well, because the teacher is less good or less than perfect in its execution. The observation of feasibility social system, are: cooperateon among the members of the group at the first meeting until the fifth performing well; cooperation of teachers and students at the first meeting less than perfect execution; freedom of expression well done; relationship between the individual and group performing well.

Components of the reaction principle, the first five meetings there are aspects of the reaction principle is not performing well, because the teacher is less good or less than perfect in its execution. The observation of feasibility reaction principles, are: the teacher creates a learning atmosphere execution group performing well; teachers provide adequate learning resources and the second at the first meeting less than perfect implementation; teachers lead students to stay in a job well done implementation; teachers donated scaffolding to the individual/group practice performing well, the teacher gives feedback implementation done well.

At first five meeting there are five aspects of the support system is not performing well, because the teacher is less good or less than perfect in its execution. Observation result of feasibility support system, are: learning implementation plan at the first meeting less than perfect execution; practical guide its implementation performing well; teaching materials practices-performing well; job sheet practices-performing well; achievement test implemented well.

Based on the results mentioned above, it was concluded that for not all the aspects observed in the study by using DSMIP meet the criteria of practicality.

(2) Description of DSMIP effectiveness in the implementation of trial

The effectiveness demonstrated by activities students in learning, student response to learning that uses DSMIP. The effectiveness of learning using DSMIP is as follows. Percentage of time used for each student activity indicators at each meeting, namely: the percentage of activity obtained that students apply the skills predictions for first and second meeting has not met the criteria of an ideal percentage of time interval specified. In addition, for the first meeting of students do not perform the skills in planning and classroom learning a bit noisy. Therefore, it was concluded that for the first and second meeting of the effectiveness of learning has not been fulfilled in terms of student activities. But for the third meeting, fourth, and fifth-learning effectiveness are met.

Student response to learning that uses DSMIP

Result analysis of student responses to learning that uses DSMIP are as follows.

1. Students gave a positive response (feel good) to:  
(1) learning activities that use DSMIP, (2) jobsheet used, (3) the learning atmosphere in class, and (4) the way teachers teach. However, students felt the learning activities that use DSMIP not a new thing.
2. Students gave a positive response (interested in following the next lesson) on learning activities that use DSMIP. In addition, students gave positive responses (understand clearly): (1) the language used on jobsheet; and (2) how teachers teach in the classroom.
3. Students gave positive responses are: (1) interested in the appearance (text, illustrations/pictures and location images) contained on jobsheet; and (2) interested in the performance of teachers teaching.

Based on the results of the trial, found that DSMIP not meet the criteria of practicality and effectiveness, thus requiring revisions before the next trial. Revised DSMIP taken is as follows.

1. Component syntax

Stage III: Organize students into groups.

Stage IV: Hands-guided.

Based on the results of an observer monitoring the two stages are not performing well, so that the second phase of join.

2. Components of the social system

Components of the social system performing well, except for teacher and student relationships at the first meeting less than perfect implementation.



3. Principle component reaction  
Components of the social system performing well, except for the provision of adequate learning resources by teachers at the first meeting and both less than perfect implementation.
4. Component support system  
Support system components performing well, except for learning the implementation plan at the first meeting less than perfect implementation.

### 3.2 Discussion of Research Results

In this section presented a discussion of research results, specific findings, and limitations of the study. The results relating to the conclusions from the results of data analysis, in order to obtain good quality DSMIP, it means that meet the criteria of validity, practicality, and effectiveness. Specific findings are the findings obtained during the research process related to the condition of students as research subjects. While the limitations of the study in question is DSMIP development strategy, particularly in the trial process.

### 3.3 Discussion of Results DSMIP

Products in this research are of good quality DSMIP. Therefore, through the development phases of learning, acquired DSMIP good quality that meets criteria validity, practicality, and effectiveness. The result of the development process of learning is as follows.

First, the development DSMIP tailored to the principles and characteristics of learning in Vocational High School then enter the aspects metacognition (metacognitive knowledge and metacognitive skills) into instructional package. Based on the results validity, obtained DSMIP valid criteria. These results, in accordance with the opinion Neeven (1999) which states that a learning material (in this case DSMIP) is said to be valid, if satisfied: (1) learning material that was developed based on a strong theoretical rationale, and (2) there is internal consistency between the components of the learning materials developed. Therefore, DSMIP developed, meet the criteria for valid, and there is internal consistency DSMIP developed.

Second, theoretically DSMIP meet the criteria of practicality. Theoretically, the results of expert appraisal & DSMIP practitioner states that can be applied in the classroom/laboratory. Being empirically, the results of field trials showed that DSMIP not meet the criteria of practicality in terms of indicators of the ability of teachers in managing learning. However, indicators of the ability of teachers in managing learning interesting for discussion. Given the teacher in SMK Negeri in Makassar had never perform learning using DSMIP. Learning undertaken

by teachers so far using conventional learning approach more dominated by the teachers, so students just listen and record what is delivered by teachers. Students are not given the opportunity to develop their own abilities. This learning process, resulting in students being passive; not used to construct their own knowledge or the solution; less to ask questions if there are not students understand the material, and less express his thoughts or his own opinion on the content being student learning. To overcome these factors, the researchers held discussions with teachers about DSMIP, then ask the teacher of learning activities using DSMIP in parallel classes that are not class-test. Consequently DSMIP practicality criteria based on indicators of the ability of teachers to manage learning for the last three meetings, including the category of at least good enough. These results, in accordance with the opinion Neeven (1999) which states that the practicality is associated with two things, namely: (1) Do the experts & practitioners claim that the learning materials developed can be applied, and (2) In fact in the field, learning materials developed can be applied. In addition, this result also undermines the assumption that states that "the ability of teachers to teach, especially in vocational education in Indonesia is very limited", so the assumption is not massive.

Third, the effectiveness of DSMIP determined by 2 (two) indicators, are: students in learning activities and student responses to DSMIP. In the trial implementation, the indicators of student responses to DSMIP meet the criteria of effectiveness, while students in the learning activity indicators have not met the criteria of effectiveness.

Basically, learning is said to be effective, if the learning objectives achieved. According to the constructivist view learning goal will be achieved, if the students actively construct knowledge in learning. Therefore, the effectiveness is also influenced by the activities of students in learning. This is in line with the opinion of Eggen & Kauchak (2006) which states that learning is said to be effective, if students are actively involved in organizing and finding information (knowledge) and the relevance of the information provided. Students are not just passively receiving knowledge given by the teacher. Learning outcomes like these not only enhance students' understanding and absorption, but also enhance their thinking skills. Thus, in learning to note how students' involvement in the organization of lessons and knowledge. Because of the more active students, the achievement of competence the greater the learning outcomes, then the learning are effective. In addition, the learning is said to be effective if it reaches the desired goals, both in terms of learning objectives and student-learning outcomes are maximized.

#### 4. Conclusion

The results of development shows the following. First, the development of student' metacognition in I EVP can be conducted by training the students' skills through: (1) Self-regulation learner, (2) the ability to think, and (3) self study. The results of individual and small groups produced that the development of students' metacognition in I EVP not satisfy the practicality and effectiveness criteria. Therefore, the development of student metacognition I EVP requires revision in the components of syntax (combining phase III and phase IV).

#### 5. Suggestions

Based on the conclusion of the study, researchers gave the following advices to practitioners who are interested to apply DSMIP in the implementation of learning in the classroom.

1. DSMIP that is produced, expanded testing has not been made and implemented widely in schools, especially at the Vocational High School (VHS). Therefore, to determine the effectiveness DSMIP, it is recommended to teachers and other researchers to conduct testing and implement DSMIP expanded on a wider scope in schools, especially in VHS. Thus, the results of research related to DSMIP can be used as a reference for developing students' metacognition
2. For vocational high school teachers who wish to apply DSMIP on other materials, can develop their own instructional package that needed by considering the relationship of metacognition aspect and the characteristics of the subject matter that will be developed.
3. Teachers who seek to improve the mastery concepts and students ability to solve problems, and increase student interest in learning, the implementation of DSMIP can be used as an alternative answer to these problems.

#### REFERENCES

- [1] Billett, Stephen. (1994). Authenticity in workplace learning settings. In J. C. Stevenson (Ed) *Cognition at work: the development of vocational expertise*. (pp. 36-75) Adelaide: NCVER. Diambil tanggal 19 Desember 2008 dari <http://www98.griffith.edu.au/space/bitstream/10072/11444/1/NCVER.CHP.pdf>.
- [2] Depdiknas. (2003). Undang-Undang RI No. 20 Tahun 2003 Tentang Sisdiknas. Diambil tanggal 4 Mei 2008, dari <http://www.dikna.org/>.
- [3] Dick, Walter & Carey, Lou., Carey, James O. (2005). *The systematic design of instruction (7<sup>th</sup> ed)*. New York: Longman.
- [4] Eggen, P. D. & D. P. Kauchak. (2006). *Strategies for teachers: Teaching content and thinking skills*. Boston: Allyn & Bacon.
- [5] Joyce, B., Weil, M., & Calhoun, E. (2004). *s of teaching (7th ed.)*. Boston: Pearson Education, Inc.
- [6] Nieveen, Nienke.(1999). Prototyping to reach product quality. In Jan Van den Akker, R.M. Branch, K. Gustafson, N. Nieveen & Tj. Plomp (Eds). *Design Approaches and Tools in Education and Training (pp 125 – 135)* Kluwer Academic Publishers, Dordrecht, the Netherlands.
- [7] Pardjono, dkk. (2003). Pendidikan kejuruan dengan kurikulum berbasis kompetensi berorientasi kecakapan hidup. *Makalah disampaikan dalam Lokakarya Pembelajaran dengan KBK Berorientasi Kecakapan Hidup*. Tanggal 29 dan 30 April 2003 di FT-UNY.
- [8] Plomp, T. (1997). *Educational and training system design*. Enschede. The Netherlands: University of Twente.
- [9] Qiuye, Sun. Yue, Qiu. Chengdong, Wu and Yanbo, Dong. (2008). *The application of iterative metacognitive theory in electrical engineering experiment teaching*. Diambil tanggal 2 Agustus 2009, dari <http://www2.computer.org/portal/web/csdl/doi/10.1109/ETCS.2009.600>.
- [10] Samsudi. (2008). Daya Serap Lulusan SMK Masih Rendah. Diambil tanggal 4 Desember 2008 dari <http://pendidikan.net/mod.php?mod=publisher&op=viewarticle&cid=46&artid=1135>.
- [11] Waras Kamdi. (2008). *Project-based learning: pendekatan pembelajaran inovatif*. Diambil tanggal 10 Desember 2008, dari <http://www.snapdrive.net/files/571708/PBL-TEORETIK-TARAKAN.doc>.

# THE DEVELOPMENT OF SELF - DIRECTED LEARNING IN TVET TO PREPARE FOR A PRODUCTIVE WORKFORCE

Isma Widiaty, Antelas Eka W, Liunir Z  
ismakurnia@yahoo.co.id

## Abstract

Facing the challenges of modern life in the 21st century, self-reliance is necessary to be able to adapt to various demands. Independence is a key for individuals to be able to direct themselves towards the goal in life. Independence is supported by the personal qualities that are marked with a mastery of specific competencies, the consistency of its founding, creative in thinking and acting, able to control himself, and has a strong commitment to the various think. In recent years, there has been intensive research into different aspects of self-directed learning. The promoting self-directed learning is asserted by making reference to the changes in economic policy, society and work organization.

The findings of the self-directed learning such as finding Hargis in 2004 that individuals who have high self-sufficiency tend to learn better, able to monitor, evaluate, and manage learning effectively, save time in completing tasks, managing learning and time efficiently, and gain high scores. This paper will discuss how to develop self-directed learning in TVET an effort to prepare for a productive work force.

**Keywords:** self-directed learning, TVET, work force.

## 1. Introduction

Self-directed learning has been known as a learning system applied in open-education or remote education. However, not all the people, even academist, understand the concept of self-directed learning. According to the writer's experience, in college, most students do not well comprehend the concept of self-directed learning (or the other terms: individual learning, self-learning, open or remote learning, etc). In this paper, the writer would like to share the idea of self-directed learning and the application in education. Basically, self-directed learning system can be applied in all education types: conventional and non-conventional. Aside from that. The writer would also like to expose that learning independence is an asset in preparing graduates to be productive manpowers. The writer hopes that the idea in this paper can enrich the pedagogical knowledge about self-directed learning and the application of academists and another professionals in TVET.

## 2. Discussion

Learning activities in universities have several different characteristics with the ones in senior high school. The most dominant characteristic is independence, both in learning practice and in self-management. University students are forced to independently learn, browse and decide their own learning material, to study and explore their own lesson material without supervision, control and regulation from the lecturers. Moreover, university students have been considered mature enough in managing their own life.

Self-directed learning can be seen as a process as well as a product. As a process (method), self-

directed learning means that self-directed learning is a way to achieve the learning objectives. Meanwhile, as a product (objective), self-directed learning means that the students are expected to be independent learners in the end of the learning process. In this second perspective, self-directed learning is reputed as a life-skill that has to be mastered by everyone. According to a study, industrial companies tend to require bussiness professionals who have self-directed learning skill, because in bussiness context, every individual is expected to continually learn. Kirkpatrick, D. (2001)<sup>2</sup> found that every bussiness institution require university graduates which are able to solve problem, adopt with changes, and coloborate with another employee.

Independence in learning refere to specific ways of students in managing their work. Schunk dan Zimmerman (1998)<sup>4</sup> described independence that the learning process is part of the impact in building the students thought, feeling, strategy and behavior which are oriented to the learning objective achievement.

From the expositions above, it is clear that self-directed learningis not only a methodology, but also an abjective. Self-directed learners have become wanted product by every educational institution especially university because self-directed learners are also wanted by the work field.

Independence is something which is formed from accurate learning processes. Self-directed behavior is a characteristic which is intentionally build, not something to appear by itself. In order to build independence, lecturer directs, motivates, accomodates and evaluates the process of the students self-directed learning, so that the classroom activity can be filled with conceptual

things and is a sort of confirmation occasion for the students to understand the material and task to be done outside the classroom. In the other hand, the students are expected to do tasks which actually they are able to do on their own with sufficient instruction from the lecturer. Therefore, the lecturer can share more wisdom than technical problems so the classroom may have additional value.

Therefore, independence in learning has to be initiated from the first time the students enter the university. It is possible if there is a sufficient handbook to be a guidance for the lecturer and the students. To emphasize, independent behavior will be formed if the classroom activities is filled with sufficient instruction from the lecturer. On the other hand, the students has to believe that the lecturer is not the main source of knowledge. The main source of knowledge is provided in libraries and printed and visual media.

Meanwhile, Song, Hill (2007)<sup>6</sup> perspective about independence in learning will be presented on a table below:

Perspectives	Description	Models		
		Candy (1991)	Brockett & Hiemstra (1991)	Garrison (1997)
Personal Attribute	Moral, emotional, and intellectual management	<ul style="list-style-type: none"> <li>Personal autonomy</li> <li>Self-management</li> </ul>	<ul style="list-style-type: none"> <li>Goal orientation (personal attribute)</li> </ul>	Self-management (Use of resources) <ul style="list-style-type: none"> <li>Motivation</li> </ul>
Process	Learner autonomy over instruction	<ul style="list-style-type: none"> <li>Learner control</li> <li>Autodidaxy</li> </ul>	<ul style="list-style-type: none"> <li>Process orientation (learner control)</li> </ul>	<ul style="list-style-type: none"> <li>Self-monitoring</li> </ul>
Context	Environment where learning takes place	<ul style="list-style-type: none"> <li>Self-direction is context-bound</li> </ul>	<ul style="list-style-type: none"> <li>Social context: role of institutions and policies</li> </ul>	

*Perspectives on Self Directed Learning*  
 (Sumber : Song, Hill;2007)

Lowry (cited from Sumarmo,2004)<sup>5</sup> summarized suggestions from several writers about how to develop independence in learning for the student, that the lecturers have to:

- Help the students to identify the starting point in learning and to develop the relevant assessment and report.
- Encourage the students to contextually see the truth and knowledge, to see the value of framework as a social construction and to understand that the student may work individually and in a team.
- Create partnership among the students through aims, strategies, and evaluation criteria negotiation.
- Help the students to arrange their priority for formulating their learning objective.
- Encourage the students to arrrage achievable objective through many ways and offer them several examples of worked performance.
- Prepare several example of achieved tasks.

Chou (2008) listed the characteristic of *independence in learning, which are:*

- a. Independence. Self-directed learners are fully responsible people who can independently analyze ,plan, execute, and evaluate their own learning activities.
- b. Self-management. Self-directed learners can identify what they need during the learning process, set individualized learning goals, control their own time and effort for learning, and arrange feedbacks for their work.
- c. Desire for learning. For the purpose of knowledge acquisition, self-directed learners' motivations for learning are extremely strong.
- d. Problem-solving. In order to achieve the best learning outcomes, self-directed learners make use of existing learning resources and feasible learning strategies to overcome the difficulties which occur in the learning process.

- Ensure the students to realize the formulated aims, strategies, sources and learning evaluation criteria.
- Train the students to inquire, make a decision, develop and evaluate themselves.
- Play the role as a supervisor in seeking the learning sources.
- Help in deciding learning sources which are appropriate with the students need.
- Help the students to develop positive behavior and values.
- Know the students learning and personality types.
- Use real experiencing and pronlem solving technique as the bases of the adult learning experience.
- Develop high quality learning guidance covering programmed learning.

However, the application of self-directed learning has different consequences. Experts suggest several considerations in applying the self-

directed learning. The considerations basically state that we have to relate that the optimum learning process can be occurred in certain conditions. Wongsri,N,et.all (2002)<sup>7</sup> identified that the optimum learning performance can occurred if:

1. The learners do want to learn.
2. The learning is done through practice, trial, error, etc.
3. The learners learn from feedbacks from somebody else (tutor, teacher, and classmates) or from themselves.
4. The learners “digest” the learning process. It means that the learners make sense of the learning and feel the application in their daily life.
5. The learning process is appropriate with the situation and condition of the students at their own pace.
6. The learning is conducted at place and time that the students decide by themselves.
7. The learners feel in control of their learning.
8. The learners work with their colleague, often with other people around, especially fellow-learners.

The statements above show that generally the learning occur independently. Aside from that, learning activity can be conducted by the support from the learning material (resource-based learning). In the other word most learning is independent and resources-based. Wongsri,N,et.all (2002)<sup>7</sup> stated that the main implication in education is on how to optimize the learning sources without eliminating the learners autonomy in managing their own learning. The forms of learning source which have to be optimize are:

1. Human-form sources
  - a. Human-form sources like tutors, teachers and classmates can give information and facilitation by:
    - Providing needed learning sources.
    - Encouraging the students’ motivation in learning.
    - Providing opportunity for the students in testing or practicing the learning theory.
    - Giving feedbacks toward the students’ development, and
    - Ensuring the learners that whatever they learn will be contextually usefull.
  - b. Meanwhile, the classmates can be functioned as learning partners by giving them opportunity to:
    - Learn from the other’s error.
    - Help each other in perceiving the material been learnt.
    - Help each other in seeking, exchanging and providing the most appropriate learning material, and

- Discuss difficult ideas and concepts together.
2. Information-type resources; historically, information-type resources is written or printed on papers such as books, moduls journals, articles, handouts or notes, handbooks, exercise books, etc. These types of information is the commonly used and usually develop source. The other information sources are a kind of computes assisted learning package (interactive CD ROM and hypermedia), computer-based communication device (computer conferencing, email, online database, and internet), or the othe learning media (video program, audio program, practical kits, etc). This second type of information mostly need electronic and computer aids (electronic and computer-based information).

In addition, Wongsri,N,et.all (2002)<sup>7</sup> suggested several consideration in optimizing the two learning sources:

1. Learning motivation is very important so the learners have responsibility to learn independently. Because of that, every learning sources (both human-based and non-human-based) should be planned and developed in order to be attractive to stimulate the learners’ motivation.
2. In self-directed leraning, the students learn by doing. Don’t let the learners learn the learning sources without giving them opportunity to practice it. The effective learning sources are sources that give opportunity to students in choosing and deciding their own task to be finally practiced.
3. The students need feedback about their learning development. The learning sources (both human-based and non-human-based) have to provide spaces for the presents of feedback towards the learning process been conducted.
4. The students have to feel that the material being learnt is meaningfull. So, they have to find the meaning of the learning in every practices they do, feedbacks they get or the activity they do in group (with classmates).

Through SDL, students’ knowledge is developed through numbers of generic skills including research finding skills and independent working. This statement is supported by Piskurich who agreed SDL is an ideal approach in generating students’ performance towards independent working. Therefore, self-directed development is needed in TVET in preparing the graduates to be productive manpowers.

### 3. Conclusion

Self-directed learning system is a system that focus on the role of students autonomy. In

education which employ the self-directed learning system, the students (both individually and in a group) are given authority in deciding (1) their learning objective (what to be achieved), (2) their learning materials and sources (what to be learnt and where the sources come from), (3) their learning strategy (how to achieve the objective), and (4) learning evaluation (when and how the achievement can be evaluated).

Self-directed learning can also be seen from two perspectives; as a method and as an objective. As a method, self-directed learning is treated as a methodology in certain education system. Meanwhile, as a product, self-directed learning can be defined as a learning system with its strategies in order to produce independent learners. Actually, education with self-directed learning system indirectly will shape and develop the the self-directed skill to produce self-directed learners.

The independence learning development in TVET is an asset for the university students to be productive manpowers in the future.

## REFERENCES

- [1] Hargis, J. (<http://www.jhargis.co/>). *The Self-Regulated Learner Advantage: Learning Science on the Internet*.
- [2] Kirkpatrick, D. (2001). *Who Owns the Curriculum Dalam Brook, B., dan .Gilding, A. The Ethics and Equity of e-Learning in Higher Education*. Melbourne: Equity and Social Justice, Victoria University, 41-48.
- [3] Pituch, K. A., dan Lee, Y.-k. (2004). The Influence of System Characteristics on e-Learning Use. *Computers & Education*.
- [4] Shunck, D.H., & B.J Zimmerman,(1998). *Introduction to the Self Regulated Learning (SRL) Cycle*
- [5] Sumarmo Utari (2004). *Kemandirian Belajar: Apa, Mengapa, Dan Bagaimana Dikembangkan Pada Peserta Didik*. Seminar Nasional .FPMIPA UPI
- [6] Song Liyan , Hill Janette (2007). *A Conceptual Model for Understanding Self Directed Learning in Online Environments*..Journal of Interactive Online Learning .Volume6, Number 1, Spring 2007 ISSN: 1541-4914.[www.ncoir.org/jioi](http://www.ncoir.org/jioi).
- [7] Wongsri,N., Cantwell, R.H., Archer, J. (2002). *The Validation of Measures of Self-Efficacy, Motivation and self-Regulated Learning among Thai tertiary Students*. Paper presented at the Annual Conference of the Australian Association for Research in Education, Brisbane, December 2002.

# ANALYSIS OF HAZARDS CONTROL AND CONDITION IN WORKSHOPS/LABORATORIES FOR ENSURING WORK HEALTH AND SAFETY IN VOCATIONAL HIGH SCHOOLS

**Putut Hargiyarto, M.Pd.**

Lecturer of Mechanical Engineering Education Departement, Faculty of Engineering,  
Yogyakarta State University  
putut\_hargi@uny.ac.id

## Abstract

The Implementation of Tri Darma University devotion through three communities was conducted through the analysis of training needs, based on entrepreneurship training, job placement and guarantee. The Appropriate goals for community services are, first, to provide the opportunity for participants in order to increase the time of knowledge, skills and mental attitude to the needs/market opportunities and job placement work on the business/industry). Second, to transfer the development of bamboo handicraft Batik on handy made with the participants to build partnership networks in order to facilitate the participants who have more control in Batik Design. Third, to educate and train residents in areas that suits the needs of the functional skills in the practical work to take advantage of both non-formal and informal sectors in accordance with the employment opportunities (Job Opportunities). This community service is funded by DP2M DIKTI DEPDIKNAS Indonesia.

**Keywords:** batik design, bamboo handicrafts, training.

## 1. Introduction

The importance of maintenance of safety and health will increase in value with the release of government policies in the development of education include: expansion of access to vocational education in accordance with local needs and excellence, through the addition of vocational education programs are more flexible in accordance with labor market demands; give content vocational education in high school for students who will work (Suyanto, 2008: 13); made SMK road map 2006-2010, in which the targeted ratio of school year 2009/2010: SMK = 50:50, with 7,000 vocational school, 3.06 million students and 217,000 teachers through several actions: imaging, scholarships, additional teachers, library development, and additional study room. More specifically about vocational development reached by a variety of strategic measures such as equip schools with library facilities, workshops and laboratories for all vocational (Joko Sutrisno, 2007: 33).

The realization of the development achievement of targets is done by a variety of learning programs, improved school infrastructure, training: teachers, staff and students, implement the Quality Management System (QMS) ISO 9001: 2000 in the administration of the school management. All was done in order to achieve the purpose of Secondary Education, Vocational, namely: human resources that could be a factor of excellence in various development sectors; transform students into a productive asset development; produce professional manpower to meet the demanding needs of industrialization, and

the demands of development generally; and equip students to develop themselves professionally. In line with the demands of globalization, there is a Vocational High School which evolved into international school (SBI) with the application of quality management standards through ISO 9001:2000 certification, the organization of school activities will inevitably have to refer to international standards, including safety and health standards work. There are twelve indicators that must be met by the International Vocational High School class. Of the twelve there are at least six indicators related to the implementation of occupational safety and health, which is a process that dangerous activities or conditions or dangerous places.

One important aspect for a SMK to manage infrastructure that includes building schools, workshops and laboratories, learning activities using tools and machines, is the aspect of occupational safety and health for all citizens of the school, whether teachers, staff, students and facilities infrastructure of schools and communities around the school. Potential threats to safety and health is generally related to the workplace or workshop production, the problems that stand out among others: the location of the workshop is very close to the classrooms and offices, so the risk of occurrence of environmental disturbances such as noise, fire hazards and air pollution. Use of tools and production machinery causing noise disturbance. Narrow working space and adjacent classrooms and offices are also at risk of air circulation and comfort are inadequate working space. Fire hazards from the operation of tools and

machinery, the use of heat sources in practical activities, and risks of using electric power. Environmental pollution arising from the use of chemicals in production processes. Meanwhile, because the educational background and work experience that includes civitas akedemika school teachers, technicians and students are a diverse workplace workshop led management is inadequate, so that exposure to hazards in the workshop and the environment threaten the safety and health teachers, staff, students and residents society in general.

Safety is the primary means for the prevention of accidents, disability and death as a result of workplace accidents. A good workplace safety is the gateway to the security of employment. Accidents caused direct and indirect losses. Direct losses include pain and death. Indirect losses include damage to machinery and work equipment, production process stops for some time, damage to the work environment, and others. (Suma'mur, 1985:2). Safety objectives are to: protect the safety of labor rights in doing work for the welfare of life and increase production and productivity of society; ensure the safety of every other person residing in the workplace; and production resources are maintained and used safely and efficiently (Suma'mur, 1985:1). One of the problems that occur almost every day at work is an accident that causes the things that we do not want, such as equipment damage, bodily injury, disability and even death. Accidents occur due to safety does not become a priority. Two of the three accidents caused by people falling, slipping, slipping, falling beams, and falling objects at work. (Daryanto, 2001: 2). Accidents that occur will result in loss of effect, because as much as possible and as early as possible, accidents / potential accidents should be prevented / eliminated, or at least reduced the impact. Causes of accidents in the workplace include: fatigue; workplace conditions and job insecurity; lack of mastery of workers to jobs, initially suspected cause is the lack of training, and characteristics of the job itself. Rudi Suardi (2005) says that the cause of accidents there are two things, namely: individual factors and employment factors; human error and unsafe conditions (Tasliman, 1993); factor of tool / machine, human factors and environmental factors (Sumantri, 1989) ; not know the procedure is safe, does not meet the job requirements and are reluctant to comply with the terms and conditions of employment (Silalahi, 1985). The risk of danger to workers in the workplace consists of: physical hazards (noise, lighting, air conditioning), biological hazards, chemical hazards and other hazardous materials as well as psychological risk (Sumakmur, 1987)

In the hazard management is known five principles of hazard control that can be used in a graduated / together to reduce / eliminate the

hazard. The five principles are: replacement, also known as engineering controls; separation through physical separation, time separation, and separation distances; ventilation; administrative control; and personnel protective equipment ( Tambunan, ). Analytical methods for implementation through five stages of the condition is called risk assessment, namely: researching and examining the dangers that exist, determine where hazards are at risk and why it happens, evaluate the risks that exist and determine whether the cause can be controlled. The fourth step is to blame or finding an existing record and the fifth is reviewing and revising the study. Ismara studies (2008) showed that most of the management workshop / vocational laboratory has not referring to the criteria of Occupational Safety and Health as appropriate. These include: the tools have not been laid out perfectly, there has been no study of potential dangers and there is no standard procedure ( SOP ) control of hazards in the workshop. Therefore, analysis of the conditions and control hazards in workshop / laboratory to ensure the safety and health at SMK is urgent and needs to be done. The results of analysis of hazard control conditions and recommendations of this is preliminary information to develop management plans Occupational Safety and Health as an important part of management workshops and laboratories Vocational High School. Objectives to be achieved from this study were to (1) know the type of hazard, (2) determine the level of hazard, (3) know the urgency of controlling hazards that must be done by the manager, and (4) obtain advice on the formulation of hazard control measures that must be done by the management workshop / laboratory.

## 2. Research Methods

The research was done with descriptive method, through a survey to describe the condition of workshop / laboratory, aims to explain the phenomenon that occurs in the scene. The subjects of this study population as well as workshops / vocational laboratory clumps of industrial technology as the Special Region of Yogyakarta. Purposively selected study sample of 23 workshop / laboratory, from a variety of expertise in vocational programs. Time study for 2 months starting in July to August 2010. Data collected by observation technique using a checklist published by the ILO. Analysis of data using techniques of quantitative analysis, by calculating the frequency of occurrence of each group of the dangers in the workshop / vocational laboratory, and then calculated the average and percentage.



### 3. Research Results and Discussion

Research carried out on various vocational school in Yogyakarta Special Region school profiles obtained under study as presented in table 1 below.

Table 1. Profile SMK Workshop/laboratory observed

No	School observed	State	Private	Total
1	Number of schools	11	4	15
2	Number of courses	9	3	12
3	Number of workshops/ laboratories	17	6	23

After a search by questionnaire and direct observation in the workshop / laboratory schools can obtain a picture of conditions that includes 9 types of hazard with 128 indicators, namely in terms of: material handling = 21, use of hand tools = 16, machine guarding = 18, the design of workplaces = 14, lighting = 10, work climate = 6, noise and vibration = 6, the facility worker = 13, the organization of work = 21. The condition is more illustrated in table 2 below.

Table 2. Risky Work Hazards

No	Scope of work	Number of indicator
1	Material handling	21
2	Use of hand tools	16
3	Machine guarding	18
4	Workplaces design	14
5	Lighting	10
6	Work climate	6
7	Noise and vibration	6
8	Worker facility	13
9	Organization of work	21
	Number of work	128

Levels of hazards are grouped into four categories, namely series: 1 = no data, 2 = no problem / no need improvement, 3 = needs improvement and 4 = priority for repairs.

Overall summary shows that of the nine occupational groups in the SMK workshop / laboratory none of which does not require any repair efforts, meaning that there is still a hazard in the SMK workshop / laboratory. In average there are 4 groups of level of hazard that occurs, no data = 6 cases (4 % ), no action = 68 cases (54 % ), need to act = 44 cases (34 % ) and need priority action = 10 cases ( 8% ), Figures 1 and 2 below show the condition of the dangers that exist in all vocational and average level of risk the danger.

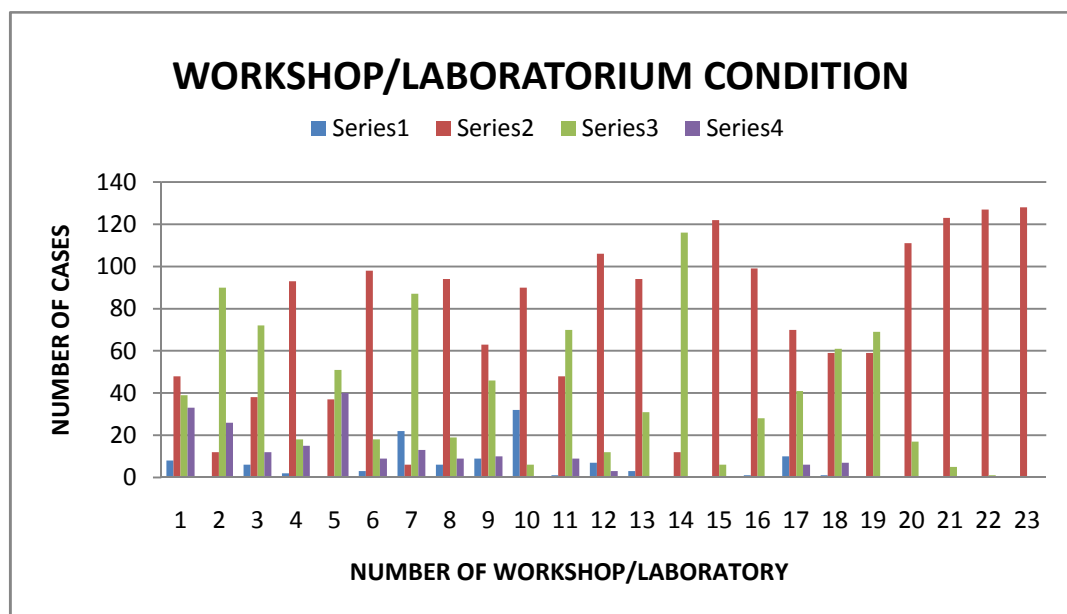

Figure 1. Workshop/laboratory Condition

In order to obtain a coherent study of the discussion refers to two things, first about the object of study that includes 9 types of hazards in the workshop / laboratory, the second refers to the four formulation of research problems. The following discussion starts from the hazards of the work contained in the SMK workshop / laboratory.

### 3.1 Material Handling

Marking a clear transportation routes and safe there are 13 cases that need improvement and 2 cases of priority improvements. Marking the route of transport in a workshop is the first step and key in the maintenance of safety and health of workers, however, as known workshop / laboratory mostly vocational development in stages, where the addition of the PBM facility is not offset by the addition of practices and arrangements lay out the workshop / laboratory, broad meaning not meet the needs of workshop equipment / facilities. This led to the placement of facilities tend to be limited room and sacrificing space safe for workers and it is very difficult to create a transportation route markers.

The narrowness of the room can actually be done with the use of material storage racks, but it also has not been maximized, so that there is need for improvement in 13 workshops / laboratories, as well as 2 workshops / laboratories that require priority to be fixed. From an exploration of the use of the shelf, most of the workshops have not applied the 5S concept where many objects / items are not regulated properly, the useless stuff is still stored and takes place, overlap, mix and not grouped by type and usefulness, and so on.

Moreover in the case of the use of tools for moving up and down the goods there were 10 cases of necessary repairs and improvements a priority case, meaning that many workshops / laboratory inadequate in an effort to secure the transfer of goods, because they tend to still use manual methods of risk back injury, hands and feet for workers. The use of lifting equipment and transport as light as hoist, trolley and so on. is an effective solution in addition to easy operation and cheap price. Furthermore, the need for adequate garbage 7 cases, this is the same as the application of the 5S concept where the workshop has not been implemented adequately hygiene, to not run with the grouping by type, use of temporary shelters and waste management as a whole.

The following was presented photographs, poor conditions and good as a comparison for complete information condition SMK workshop / laboratory.



Figure 2. Bad Material Handling



Figure 3. Good Material Handling

Finally, the relation with the space limitations of the tagging workshop also affect the way out and the freeway. In this case there were 10 cases need to be improved and 2 cases of priority improvements, mostly due to the distance between the space between buildings and narrow. However there are things that are already well under way, among others, in terms of flatness of the road, not smooth and free of bumps or holes, use a simple tool for moving as yoke, levers and so on.

### 3.2 The use of hand tools

Hand tools in the SMK workshop / laboratory is still very widely used, but if referring to the industry standards are still many things to fix, for example in terms of the importance of the use of assistive devices for precision work, it is in respect of work in the workshop / laboratory for precision has not become the main criteria, so that the tool also has not helped him become a priority. Next use the tool mounting for ease of operation, care and maintenance and training use of the tool before operating. Although seemingly trivial in the form of hand tools, but because of the risk of substantial harm, then its management become absolute claim should be observed, especially the frequency of use of hand tools is still quite dominant in the work in the SMK workshop / laboratory. You do this by providing a sufficient portion for the care and maintenance, routine maintenance and incidental to the urgent maintenance.

### 3.3 Machine protection

For the protection of machinery, some cases that stand out are: the use of the emergency switch (5 necessary, priority 4 ), use a different switch (8 necessary, 2 priority), the switch position and movement of natural sequence (5 needs, 1 priority), the use of warning signs that easily understood and easily observed (13 necessary, 1 priority ), the use of jigs and fixtures (10 necessary, 2 priority), a protective engine (10 necessary, 2 priority), care and maintenance of machinery (9 need ), and safety training (8 need, 2 priority). None of the 19 indicators of the dangers of using the machine without the need to improvement. This means that the workshop should be carried out remedial measures in order to safe and secure conditions. The cases that occur, this is a picture of a lack of management workshops / vocational laboratory in understanding the importance of OHS in the workshop, although still modest and limited facilities but also the safety and security aspects have not been to school culture.

### 3.4 Workplace design

Many SMK developed a minimal set of conditions and little by little the manager can add facilities to learn the tool, but it also has not been offset by adjustments to the comfort of work, where frequent use of tables, chairs and a roar that did not fit with certain types of work. For example, less high chairs, the table does not flat, that is not ergonomic computer desks and so on. Measures that can be done is to rearrange lay out the workshop, based on group work and readjust the table, chair and other tools so that more ergonomic.



Figure 3. Good workplace design



Figure 4. Good workplace design

### 3.5 Lighting

Most workshop / laboratory is optimizing natural lighting, this is very aware that the use of lighting can be very costly additional electric power budget to be paid. However, in case / specific work required local lighting is adequate, this can be obtained with additional local lighting and can not rely on natural light only. To determine which part needs to local lighting should be measured against the needs of the lighting and then do what the addition of lights.

### 3.6 Work climate

The case of work climate that often arises is due to the hot weather of the tropics, where the workshops have not been able to provide an additional tool in the form of air - suction blower, air conditioning, and maintenance procedures. If the work climate settings rely entirely on electric power would be very wasteful, and therefore should be regulated so that natural ventilation can be optimized, the layout items that allow air circulation going well, and maintain the cleanliness of the scattered dust.



Figure 5. Bad work climate



Figure 6. Good work climate

### 3.7 Control of the dangers of noise, vibration and electrical

Besides the weather, the SMK workshop / laboratory is also very familiar with the condition that noise, vibration, voltage, all of which must be controlled. This danger from the operation of machines, usually due to machines that have been long and wear out causing noises and vibrations. Therefore, care and maintenance factors machines become key to how noise and vibration can be

addressed properly. Moreover, it can be done by providing insulation against noise sources and the use of earplugs for teachers, technicians and students.

### 3.8 Worker Facilities

The next hazard risk control measures that need is the provision of working facilities which include: toilets, canteen, meeting room / training, personal protective equipment are adequate. Here the term is a multipurpose room, where all the goods and the activities carried out here and forget about the aspects of OHS. In most vocational facility is not a priority for the workers organized, such as adequacy and cleanliness of toilets, availability of adequate PPE for teachers, technicians and students. In this case the provision of PPE to be an urgent priority and urgent action, as well as a picture of the SMK OHS's which is still inadequate.

### 3.9 Work Organization

Unlike in the industry, the organization of work in the SMK workshop / laboratory mostly just involve administrators, teachers and technicians, while students have not played a major role. However both managers, teachers and technicians should be able to work together to realize the governance workshop / laboratory is an effective and efficient. A more frequent problem is communication and involvement of all stakeholders in an egalitarian towards workshop conditions are convenient, safe and secure. Therefore, workshop managers should involve all components from planning, guidance and training, establishment of working groups, provision of performance incentives, development of emergency response plans and make continuous improvements. With the standardization of existing approaches is default standard procedures, establish residence and ensure that all procedures have been running smoothly without a hitch.

In total of 9 groups of occupations in the workshop / vocational laboratory, there are some hazards that need priority handling in the material handling: layout of the workplace, the shelves where goods, the use of transmission devices and marking out the space workshop / laboratory. On the use of hand tool: aspects of equipment maintenance and training in the use of tools. On the machine protection: emergency switch, tagging and color displays, jigs and fixtures, machinery and protective workers, hygiene and care. In the design of the workplace: the height and arrangement of chairs and tables, training and worker involvement in workplace reform. Lighting: local lighting and glare. Weather work: heat insulation, local air suction and maintenance tools. Noise and vibration: engine maintenance, chemical hazards. Facilities workers: toilets, PPE and job

responsibilities. Organization of work: cooperation and communication, involvement of all the parties.

## 4. Conclusion

Conclusions can be drawn from this study were (1) Types of hazards found in the workshop / laboratory Vocational High School includes nine occupational groups / matters relating to: material handling; the use of hand tools; engine protection; design of the workplace; lighting; weather work; hazard control noise, vibration and electricity; facility workers, and labor organizations, (2) The mean level of hazard contained in the workshop / laboratory Vocational High School include: not dangerous (68 cases = 54%), need to action (43 cases = 34%), and need priority action (10 cases = 8%), while the other 4% or 6 cases there is no data, (3) Control hazards that must be done by the manager workshop / laboratory with a high importance is the case on condition of risk priorities for improvement actions threaten the safety level of danger. The next stage is the case that need corrective action, while the latter is to maintain and improve the conditions in case that does not need corrective action, (4) Recommendations for improvement of the conditions is done by stages: setting goals, choosing the approach, establish procedures and conduct ongoing evaluation of the condition of OHS in the workshop / laboratory.

As for some suggestions to reduce the risk of hazards and improving worker safety in the workshop / vocational laboratory are: (1) needs to be audited more carefully and deeply about the state of OHS in vocational school, preferably using standard certifications such as ISO 18000 OSHAS or, (2) the need for increased maintenance actions and maintenance workshop facilities / laboratories and taratur programmatically using a variety of approaches has been widely applied in industry, among others 5S, kaizen, etc. TQC., (3) the need to involve all parties to user workshop / laboratory: teacher, technicians, students and guests in an effort to create a safe, comfortable, healthy and safe as part of the cultural and productive character.

## REFERENCES

- [1] Daryanto, Keselamatan Kerja Bengkel Otomotif, Jakarta: Bumi Aksara, 2001, pp. 2.
- [2] Ismara, KI, Kajian Pengembangan Sistem Manajemen Perawatan dan Penataan Sarana Prasarana Sekolah Menengah Kejuruan, Research Report, Jakarta: Direktorat Pembinaan Pendidikan Menengah Kejuruan, Ditjen Dikdasmen Depdiknas, 2008, unpublished.
- [3] Joko Sutrisno, Kebijakan Pengembangan Sekolah Menengah Kejuruan, National Seminar Paper on Vocational School Development Policy, Faculty of Engineering, State University of Yogyakarta, 2007, pp.33

- [4] Rudi Suardi, Sistem Manajemen Keselamatan dan Kesehatan Kerja. Jakarta: PPM Publisher, 2005.
- [5] Tambunan, Keselamatan dan Kesehatan Kerja. Taken on March 12, 2010 from: ([http://www.freewebs.com/stb\\_tambunan/OSH.htm](http://www.freewebs.com/stb_tambunan/OSH.htm) # # Sub1 Sub1 )
- [6] Silalahi, Bennet N. B. and Rumondang B. Silalahi, Manajemen Keselamatan dan Kesehatan Kerja, Jakarta: PT Pustaka Binaman Pressindo, 1985
- [7] Suma'mur, Higiene Perusahaan dan Kesehatan Kerja, Jakarta: Gunung Agung, 1985, pp 1-2.
- [8] Suma'mur, Keselamatan Kerja dan Pencegahan Kecelakaan, Jakarta: CV Haji Masagung, 1987.
- [9] Sumantri, Teori Kerja Bangku, Jakarta : Departemen Pendidikan dan Kebudayaan, 1989.
- [10] Suyanto, Kebijakan Pendidikan Dasar dan Menengah dalam Peningkatan Kualitas Pendidikan. Seminar Paper of Education Quality Improvement Strategy. Graduate Program in the State University of Yogyakarta, 2008, pp 13.
- [11] Tasliman, Keselamatan dan Kesehatan Kerja. Yogyakarta: Fakultas Teknik Universitas Negeri Yogyakarta, 1993, unpublished.

# PART THREE

Financing and Infrastructure: The  
Alternatives of Vocational Education  
Financing

# **EDUCATIONAL INFRASTRUCTURE AND WORKFORCE DEVELOPMENT IN TOURISM AND HOSPITALITY INDUSTRY: THE CASE OF THAILAND**

**Chanin Yoopetch**

Mahidol University International College, Mahidol University, Thailand  
icchanin@mahidol.ac.th

## **Abstract**

The purpose of this paper is to discuss educational infrastructure and key factors relating workforce development in the tourism and hospitality industry in Thailand. The tourism and hospitality industry is one of the most important industries to the Thai economy. To support the development in this sector, the educational infrastructure is the key element and similar to other service sectors knowledgeable and skillful human resources are highly important for the success of the industry. The conceptual model was proposed and highlighted the collaboration among public sectors, private sectors and educational institutions for the success of workforce development in the long run.

---

## **1. Introduction**

The growth of the industry is the key drive to increase the demand for graduates in the areas of tourism and hospitality. Human resources become known as the major factor in service industry, including tourism and hospitality. For Thailand, the tourism industry is one of the most important sectors, leading to the economic development and regeneration in all provinces. Tourist destinations are highlighted and promoted throughout the country and this helps support employment and economic revival through the mechanism of tourism activities and services in the hospitality industry. Therefore, the workforce development to provide skills and knowledge for the labors is greatly vital, especially the systematic educational system in both vocational education and higher education.

## **2. The Importance of Educational System**

Education is foundation of providing knowledge while training can lead to enhanced skills of the workforce. Both vocational and higher educational programs directly affect the knowledge and skills of worker to prepare students to be ready for the work environment. Anderson (2008) mentioned that vocational and training education has the important role in creating certified and skillful workforce for public and private sectors and can be considered the crucial tool for economic development and social sustainability. In addition, the important goal of vocational education includes providing skilled labor and supporting students into continuous learning process to enhance to employability in the marketplace (Maliranta, Nurmi, and Virtanen (2010).

According to European Centre for the Development of Vocational Training (VET) (2011), the benefits of Vocational and Education Training programs include both economic and social aspects.

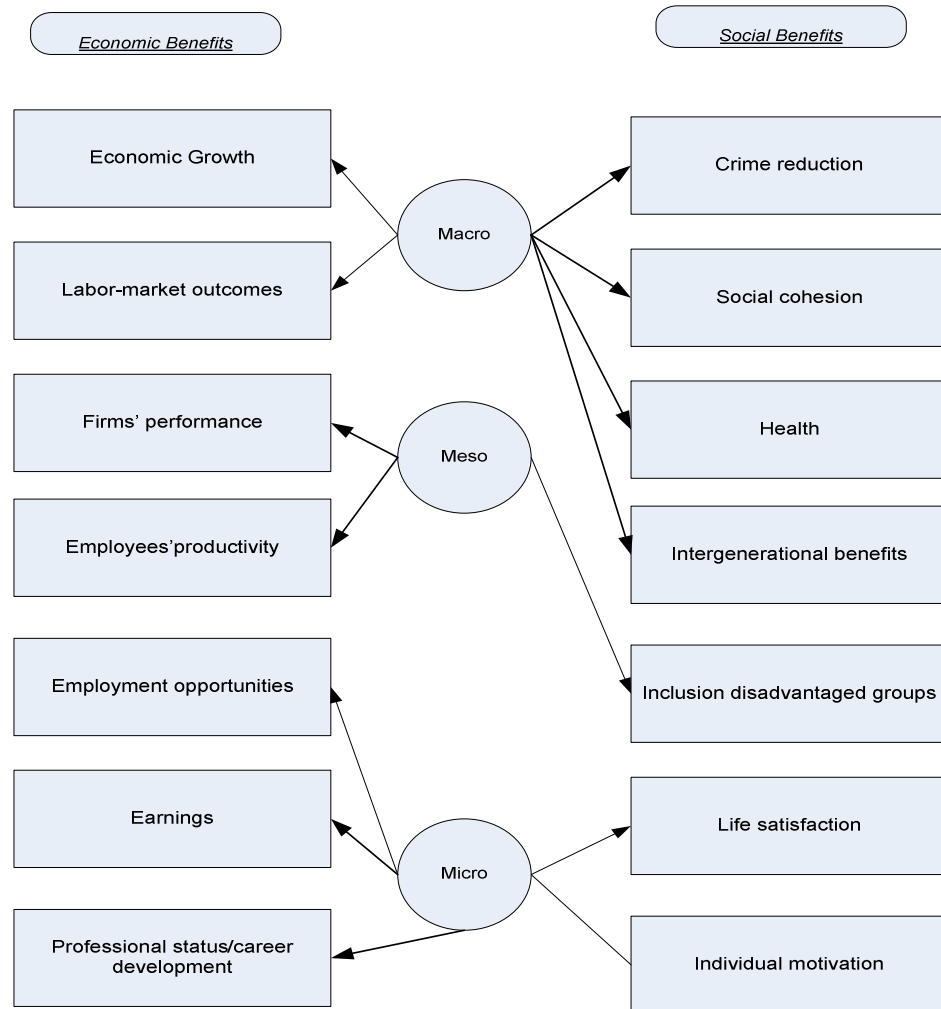

Figure 1. Types of Vocational Education and Training (VET) Benefits

**Source: European Centre for the Development of Vocational Training (2011)**

The main benefits for the economy included are classified in more details as follows;

**Macro level:**

- economic returns: research on the evaluation of public and private investment in terms of profitability and economic growth
- Labor-market outcomes: reduction of unemployment and inequality

**Meso level:**

- performance of enterprises: costs and benefits of training in terms of profitability and innovativeness
- employee productivity: individual abilities and capacity to contribute to profit

**Micro level:**

- the benefits on individuals: earnings, finding a job, reduction of skill mismatch, integration into the labor market with satisfactory wage, further career development opportunities and professional status
- In the aspects of social benefits, there are multi-levels in benefits as follows;

**Macro level:**

- effects across generations within families and how family impacts on skills development
- social cohesion: multidimensional concept measured by, for example, tolerance, trust, formal and informal networking (social and relation capital)
- education can reduce delinquent and criminal acts in a society

**Meso level:**

- Inclusion of disadvantaged or marginalized groups through education

**Micro level:**

- Personal well-being: quality of life for individuals and effects on personal development, attitudes and motivation

**Thailand National Education Background**

Table 1 and Table 2 showed the number and rate of students by level of education and the budget of education.



Table 1. Number and Rate of Pupils and Students by Level of Education: Academic Year 2004-2006

Level of Education	Age Group	2004	2005	2006
<b>Total</b>	<b>3-21</b>	<b>75.7</b>	<b>73.2</b>	<b>65.3</b>
Pre-Elementary Education	3-5	82.5	87.6	88.0
Elementary Education	6-11	102.9	98.5	98.3
Secondary Education	12-17	74.2	68.7	72.8
- Lower Secondary	12-14	89.9	82.9	86.7
- Upper Secondary	15-17	58.1	54.3	58.8
(General Education)	15-17	36.6	32.1	34.6
(Vocational Education)	15-17	21.5	22.2	24.2
- Higher Education	18-21	32.8	34.9	24.2

Rate per 100 Persons

Source: National Statistical Office (2011)

Table 2. Budget of Education: Fiscal Year 2005-2006

	2005	2006
<b>Budget</b>	<b>238,513.3</b>	<b>265,748.9</b>
Pre-Elementary, Elementary Education and Secondary Education	160,196.8	174,136.9
Higher Education	40,131.8	48,095.5
Not Classify	3,557.6	334.2
Administration Support Ed.	30,704.9	33,630.9
Others	3,922.2	9,551.4
Total Budget of Expenditure	1,250,000.0	1,360,000.0
Gross Domestic Product (GDP)	7,195,000.0	7,878,500.0
<b>% Budget of Education</b>		
Total Budget	19.1	19.5
GDP	3.3	3.4
Budget of Education Per Pupil	16,898.0	18,201.3
Pre-Elementary, Elementary Education and Secondary Education	12,673.4	13,594.5
Higher Education	27,218.3	26,850.8

Million Baht

Source: National Statistical Office (2011)

Thailand's education budget was accounted for 3-4% of the gross domestic products. A significant amount of budget was spent on higher education.

The number of students entering higher education had declined from 34.9% in 2005 to 24.2% in 2006. For the vocational education, most students were in the age range of 15-17 years old. The proportion of the students in this educational level had increased from 21.5% in 2004 to 24.2% in 2006.

Office of the National Education Commission (2011) has reviewed the current situation of vocational education in Thailand and provided strengths, weaknesses, opportunities and threats as follows;

#### Strengths

1. There are more than 800 vocational education institutions (public/private) all over the country.
2. There are 9 ministries responsible for human resource development. This can provide a variety of curricular and different forms of training to suit target groups.
3. The number of private vocational institutions is quite high, about 345. This shows their interest in participating in vocational education.

#### Weaknesses

1. There is a lack of unity in terms of policy guidelines. The country does not have a master plan for human resource development. Therefore, the provision of vocational education is more supply-driven.
2. The most crucial problem is quality of the output. A significant number of graduates have weaknesses in both theory and practice. The issues of curriculum and the process of training must be addressed.
3. The lack of R&D on vocational education to produce new technology and also generate new jobs.
4. The lack of qualified and experienced teachers. Most teachers do not have direct experience in the industry.
5. The lack of incentives for vocational teachers.
6. The lack of cooperation between vocational institutions and the industry.

#### Opportunities

1. The constitution of 1997 and the National Education Act 1999 give high priority to education and vocational education.
2. Private organizations, such as the Federation of Thai Industry, the Council of Thai Commerce, are keen to play a role in the policy process, standard setting, quality assurance, and training activities.
3. The cabinet has just approved in principle on Skill Development Fund (about 300 million

baht) which could promote the concept of lifelong learning/training.

4. Thailand has an expanding infrastructure on information technology which could be utilized for vocational education and training.
5. The society is well aware of education and work. In the past, people had more value on certificate and diploma.
6. Thai labor force has a good potential. In the Skill Olympics, Thailand has improved every year from 1993-1999.

#### Threats

1. The economic crisis in Thailand has made it very difficult to improve vocational education, particularly on large investments.
2. The state policy is not sustained due to the frequent change of governments.
3. Based on the existing human resource development programs, it is expected that Thailand would have a shortage in human resources in many industrial areas for the near future.

In addition, Fry(2002) suggested several crucial issues which occurred in the Thai educational systems, including higher education in Thailand. The first issue is about lack of unity and coordination of diverse and fragmented Education/human resources development efforts. Secondly, the problem is regard to overemphasis on bricks and mortar relative to investing in people (teacher learners; researchers). Thirdly, inadequate utilization of information communication technology for improving human resource development led to the delay and inefficiency in the development process.

According to the research report of Office of the Education Council (2004), another important issue in public funding to public educational institutions showed two major problems, an inefficient and ineffective financial management system and uneven advantage over private educational institutions. From statistics, over 70 percent of operating cost came from government budget while the rest of approximately 25 percent are from tuition fees. Comparing to the tuition fees of the private institutions, public institutions have three to five times lower. Another main problem of public fund was inadequacy of the budget. Most of the budget was spent on maintaining the operations, 30 % were on buildings and equipments and limited amount of budget was left for quality development projects.

However, the evidence from the United States indicated that funding problems may be unavoidable when the cause of the problem is external. According to NCSL Fiscal Affairs Program (2011), funding for all educational systems was reduced significantly and the major cause of the problem was economic recession. The economic recession has negative impact on public

funding for education and the chronic decline in the US economy has resulted in lower public funding to schools and universities throughout the country (NCSL Fiscal Affairs Program, 2011).

### **Thailand's Tourism and Hospitality Industry and Education**

Tourism has been on one of the most important national goals and several ministries (including Ministry of Tourism and Sports, Ministry of Commerce, and Ministry of Foreign Affairs) have plans and policies related in promoting tourism related activities and events. Tourism industry has always been the focus of the economic development in Thailand for many years. For the economic perspective, Thai tourism industry is one of the most important industries with its contribution to the economy for approximately 7% (Tourism Review, 2010). For the support of the government in the tourism industry, according to Country Report (2009), the Thai government has provided the stimulus packages of Bt1.4trn (US\$40bn) in the special program focusing on the infrastructure projects and more investment in three main areas, including tourism, health and education.

Edgell, Allen, Smith and Swanson (2008) highlighted the important factors for development of the professionalism of the workforce in tourism and hospitality industry to meet with ever-changing global demand. The foundation of success in the professionalism of the workforce lies heavily on tourism education and training programs in which the whole process of education has to be taken into consideration from high school to higher education. To provide sufficient infrastructure for the new challenge of the industry, educators have to work closely with employers and other stakeholders to be certain that all resources and tools are well-

equipped and high degree of readiness for providing education and training for the students to improve their knowledge and skills. Matching the expectation in both quality and quantity of tourism and hospitality workers is the great challenge for all stakeholders.

To provide the education system to support the work in the industry, educators and stakeholders have to be able to understand the meaning and definitions of the work environment. For tourism, Baum (1995) mentioned that there is no easy way to describe the term "tourism", because the area of tourism has included the range of scopes such as travel and transportation, catering, accommodations, recreation and sports, culture, history and heritage, natural sites, built attractions, events, retailing, conferences and conventions, tourism and hospitality information and facilitation; and tourism hospitality support services. Moreover, the scope of tourism has continued to change and be broader over time.

Mulcahy (1998) pointed out that to determine the economic competitiveness of the country, this relies on the quality of training and education is considered the most crucial factor and the emphasis on the quality has to be revised and be on the path of continuous improvement for the sustainability of the education development in the areas of tourism and hospitality.

Edgell, Allen, Smith and Swanson (2008) had suggested that model of tourism education policy as shown in Figure 2. The figure provided the relationships among tourism environment and world of education through mechanism of government policy on education and tourism and lastly tourism education can be successful if the main focus is on the implementation of all the policies.

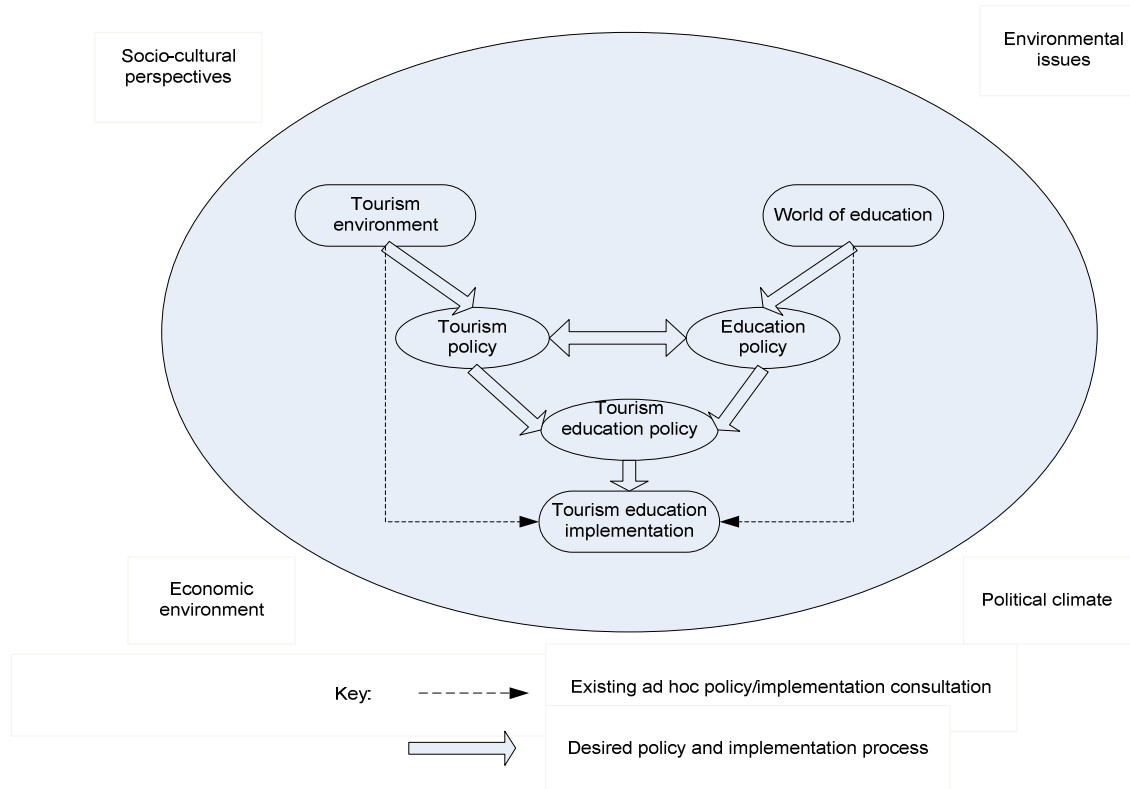

Source: Edgell, Allen, Smith and Swanson (2008) p.244

Figure 2. Tourism Education Policy-Tourism Education Implementation Model

According to Thailand Tourism Development Research Institute (2011), several of educational institutions offered the tourism and hospitality programs as shown in the table below.

Table 3. Types of Educational Institutions and the Number of Educational Institutions with Tourism and Hospitality Programs in Thailand

Types	The number of Educational Institutions with Tourism and Hospitality Programs in Thailand
Public University	16
Private University	14
Rajabhat University (formerly known as the teachers colleges)	34
Vocational Educations	19

Source: Thailand Tourism Development Research Institute (2011)

From the table above, there are only 19 educational institutions in vocational education offers the tourism and hospitality related programs. At the university level, there are 64 institutions, both public and private, providing from bachelor's degree to doctoral level in this areas. Clearly, the supply of workforce is limited at the vocational level and this causes the shortages in supply for the labor in this group, which is highly important to the tourism and hospitality industry. One explanation

for the small number of vocational education is that the Thai social value in education prefers bachelor's degree and this causes the problems in the large number of graduates who have bachelor's degree while the significant number of jobs require the educational level of vocational education. This creates the gap between demand and supply in that job and recruitment markets, Rupavijetra(2011). In response to the lack of supply from the vocational level, some private sectors, especially hotels, in

Thailand started their own institutions to provide skills and knowledge matched to their customer demands and to offer additional channels for those interested in learning and skill development in the hospitality industry. The example is Dusit Thani College, under Dusit Thani Group of companies, also known as Dusit International, a Bangkok-based hotel and resort company (Dusit Thani College, 2011). The company provides education and training through its own infrastructure and investments.

Hong (2009) noted the importance of workforce or human resources by concluding that human resources development for supporting tourism industry can be considered endogenous comparative advantages. To develop this advantage, the main focus is on education in commerce, training on job and protection of natural resources. Additionally, investments in infrastructure are highly necessary for supporting the development of tourism environments, such as accessibility design, accommodations, and transportation systems.

In order to solve the barriers of educational development, Elliott and Smith (2005) suggested the collaboration among stakeholders, for example, the tourism and hospitality industry needs to partner

with government and educators to effectively apply newly accessible technologies, tools, processes and methods, such as e-learning or distance learning to provide effective training and education for their workforce.

Among all the challenges in the educational systems for supporting tourism and hospitality industry, Thai government projected that in year 2015, the demand for workforce in several areas, including tourism, automobile parts and electronics is expected to be significantly increased. In addition, the need for workforce in these industries requires 90% from vocational education while only 10% from higher education. This highlights the demand for labors from vocational education to increase from 40% to 60%. Therefore, educational institutions have to cooperate with their stakeholders including businesses and government agencies to support the new trend (Thaipost,2011).

Considering all related concerns and issues, the author provided the model including important factors and stakeholders which have to cooperate effectively to generate the effective educational infrastructure and lead to workforce development in tourism and hospitality industry as shown in Figure 3.

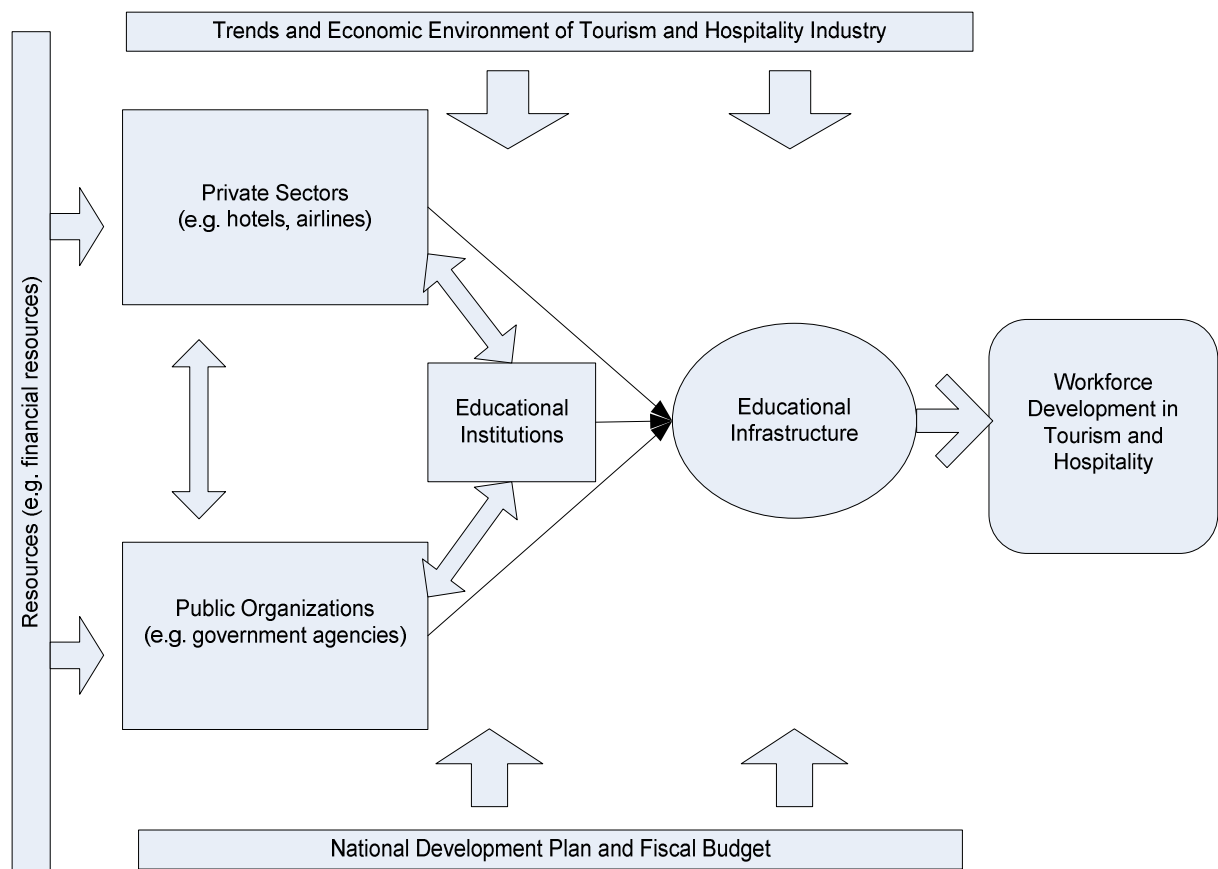

Figure 3. The Conceptual Model of Educational Infrastructure and Workforce development

### 3. Conclusions

The educational institutions in the area of tourism and hospitality cannot achieve their goals if they can only provide knowledge, but not skills. Therefore, throughout all the years in the study program, the combination of providing knowledge and skills has to be clearly included to the students. In addition, Jafari and Ritchie (1981) mentioned that it is very important to identify the body of knowledge which tourism professionals feel is necessary for a sound education in tourism. In addition, the roles of educational institutions are clearly not just to respond to the need of the industry, but also to make the industry ready for the new trends or issues arise from both internal and external environment through many methods, including research and development. For the long-term development of vocational education in Thailand, National News Bureau of Thailand (2011) reported that the future of vocational education is moving toward more internationalization and one of the goals is to create international vocational education centers in Thailand and neighboring countries. For this reason, it is important to strengthen the collaboration among partners in the region of Southeast Asia, especially Cambodia, Laos and Vietnam. Moreover, Anderson (2008) provided the insights that external factors have been changed constantly including cultural transformation, climate change and global forces. Therefore, all stakeholders should be highly aware of the trends and changes in the environment because the quality of education in both vocational education and higher education has to be highly responsive to the changing external environment. Apart from basic skills and knowledge on the specific tasks, multitasking skills become highly significant to help the workforce ready to deal with higher task complexity and ever-changing demands of the industry and customers. In addition, the contents of education and trainings have to be frequently reviewed by educators and stakeholders to meet the current and future expectations. The improvement of the educational quality takes times and significant resources. Effective planning, committed government policy and supports, sufficient public funding and well-planned workforce development implementation and involvement of stakeholders are important ingredients for sustainable development of tourism and hospitality industry to develop high-quality workers.

### REFERENCES

- [1] Anderson, D.(2008), Productivism, Vocational and Professional Education, and the Ecological Question, *Vocations and Learning*, 1, pp. 105-129
- [2] Baum, T. (1995). *Introducing a Paradigm of Sustainable Human Development for the Hospitality and Tourism Industry*, 1995 CHRIE Conference.
- [3] Country Report (2009), *Outlook for 2010-11: Economic policy outlook*, Thailand.p.6
- [4] Dusit Thai College, <http://www.dtc.ac.th/v2009/English/index.html> accessed on 5 June 2011
- [5] Edgell, D.L., Sr, Allen, M.D., Smith,G., and Swanson,J.R. (2008), Chapter 7 *Education and Training in Tourism, Tourism Policy and Planning*, pp. 219-257
- [6] European Centre for the Development of Vocational Training (2011), *The Benefits of Vocational Education and Training*, Luxembourg: Publications Office of the European Union, [http://www.cedefop.europa.eu/EN/Files/5510\\_en.pdf](http://www.cedefop.europa.eu/EN/Files/5510_en.pdf) , accessed on 3 June 2011
- [7] Fry, G.W.(2002), *The Evolution of Educational Reform in Thailand*, <http://www.worldedreform.com/intercon2/fly.pdf>, accessed on 14 June 2011
- [8] Hong, W.C. (2009), *Global Competitiveness Measurement for the Tourism Sector*, *Current Issues in Tourism*, 12(2), pp. 105-132
- [9] Jafari, J. and Ritchie, J.R.B., (1981),*Toward A Framework for Tourism Education: Problems and Prospects*, *Annals of Tourism Research*, pp.13-34
- [10] Maliranta, M., Nurmi, S., and Virtanen, H. (2010), *Resources in Vocational Education and Post-Schooling Outcomes*, *International Journal of Manpower*, 31(5), pp. 520-544
- [11] Mulcahy, J.D. (1998), *Vocational Work Experience in the Hospitality Industry: Characteristics and Strategies*, *Journal of European Industrial Training*, 22(3), pp. 128-137
- [12] National News Bureau of Thailand (2011), *VOCATIONAL HUB*, <http://thainews.prd.go.th/>, accessed on 10 June 2011
- [13] National Statistics Organization (2011), *Education*, [http://web.nso.go.th/en/indicator/soc/soc\\_edu08.pdf](http://web.nso.go.th/en/indicator/soc/soc_edu08.pdf) , accessed on 14 June 2011
- [14] NCSL Fiscal Affairs Program (2011), *State Funding for Higher Education in FY 2009 and FY 2010*, <http://www.ncsl.org/documents/fiscal/HigherEdFundingFINAL.pdf> ,accessed on 25 May 2011
- [15] Office of the Education Council (2004), *A Report in the Series of Research and Development Project on Higher Education Management System: A Summary of Financing of Thai Higher Education: A Summary of Financing of Thai Higher Education*, Office of the Education Council, Ministry of Education, Bangkok
- [16] Office of the National Education Commission (2011), *Vocational Education Reform in Thailand*, <http://www.edthai.com/reform/apr18a.htm> , accessed on 1 June 2011
- [17] Office of Vocational Education Commission (2011), *Office of Vocational Education Commission* <http://stat.vec.go.th> , accessed on 1 June 2011
- [18] Rupavijetra, P. (2011), *Education and Skills: The Challenging for Education*, <http://home.hiroshima-u.ac.jp/cice/forum/103presentation.pdf> , accessed on 6 June 2011
- [19] Thailand Tourism Development Research Institute (2011), *Thailand Tourism Development Research Institute*, <http://www.ttresearch.org/home/>, accessed on 13 June 2011

[20] Thaipost (2011), รัฐหนุนปั้นนักเรียนอาชีพะเอกชนระบุต้องการ3แสนคน, <http://www.thaipost.net/news/250511/39101>, accessed on 6 June 2011

[21] Tourism Review (2010), Thailand's Tourism to Lose More Than \$1 Billion <http://www.tourism-review.com/thailand-facing-losses-in-tourism-business-2010-news2152> , accessed on 30 May 2011

# THE CNC SIMULATOR AS TEACHING AND TRAINING AID OF CNC PROGRAMMING

Bambang Setiyo Hari Purwoko

Jurusan Pendidikan Teknik Mesin FT UNY  
bambang\_shp@uny.ac.id - bambang\_shp@yahoo.co.id

## Abstract

CNC machine tools is the most important practical means of teaching and training of CNC Programming in Vocational High School. Its relatively-high price causes the incapability of the school for getting it, so the teaching of CNC programming in Vocational High School mostly doesn't use CNC machine. The effect is many students can't reach the standard competence of applied CNC programming.

The unavailability of CNC machine tools in teaching of CNC programming in Vocational High School is treated by using CNC Simulator. The CNC Simulator consist Virtual CNC, and CNC Machine Simulator. It's a media to simulate of NC Part Program execution. The simulation of NC Part Program execution are displayed tool path a machining process at monitor. NC Part Program has been simulated can be sent to unit control of CNC Machine Simulator.

Implementation of CNC Simulator in teaching and training of CNC programming begins from building CNC Virtual. The CNC Virtual is a software which provides a visual effect of environment of CNC machine in the monitor. The building uses Research and Development (R&D) method. Implementation of CNC Simulator in teaching of CNC programming shows; (1) the students are very interested and excited to use the virtual CNC which provides a visual effect of environment of CNC machine in the monitor, actively trying the simulation of numpad virtual in the monitor, inputting data on the panel virtual, and making simulation or execution of the CNC program at CNC Machine Simulator, (2) the students practice to make and execute the CNC programming individually in the classroom or outdoor class. (3) CNC Virtual can be used as teaching and training media classically (in classroom), individually learning, even e-learning.

**Keywords:** cnc-simulator, teaching-aid, cnc programming

## 1. Introduction

National Education Government had decided that Education Development concerns with three sectors, one of them is relevance and competitive education quality improvement. The improvement of relevance and competitive education quality is done by addapting the curriculum of education to the need of people which is dynamically develop. That addaptation must really exist in the form of teaching, guiding, and training. Teaching is for giving knowledge, guiding is for stimulating constructive behaviour, whereas training is for improving skills.

One of the sectors which develops fast, especially in the industries, is system of production process automation. Nowadays, almost all of industries is always expanding production process automation and replacing manufacturer tools which are used with machines and tools which can be controlled automatically for supporting the automation.

For improving the relevance and competitive education quality, this automation system is included to the curriculum, especially in the machine engineering education curriculum, starting from Machine Production department in the

Vocational School to the Machine Engineering department in the universities. However, including production automation system to the curriculum is not easy for many factors.

Stated by Indra Djati Sidi (2001 : 37), that based on the some education researches, teacher is one of the dominant factors which influences much learners success in transforming science and technology, also morality and ethics internalization. According to Winarni Surakhmad's opinion (Pannen, dkk, 1999 : 6), holding education needs certain requirement. Besides professional teachers, it also needs cost and proper education infrastructure. If education is held without considering the requirements, there will be bad condition which can cause the process not to be qualified and the learning goal will not be achieved.

Not-proper infrastructure condition can be found often in the reality. The most is in the learning process of CNC programming, that is one of the automation, in the universities or machine engineering department of Vocational School.

CNC machine which is the main facility for forming competence of CNC operating and programming is less than the number of students, even many machine engineering departments don't have one.



The consequence causes learning process of CNC is held in group and in turn when operate the machine. For machine engineering departments which don't have one, the process is held without CNC machine. Those condition cause students don't have chance for having interaction to the machine then they don't have experience in operating machine that ability in making CNC program can't reach the standard.

Quality improvement of CNC learning can be done by giving chance as much as possible to each student for practising making CNC program and applying them to the CNC machine. However, to provide CNC machine as many as the students number needs high cost and not every machine engineering department is capable. Therefore, to fulfil the need of CNC programming learning, virtual reality CNC needs to develop.

Virtual reality CNC media is a computer program and when it runs, on the screen there will be two dimensions image of CNC machine completed with operating buttons resembling to the real CNC machine. Virtual operating buttons on the screen can have the function as the real buttons on the real CNC machine. This media is the representation of the CNC machine, functioned (1) to simulate buttons functions on the control panel, (2) simulate inputting CNC program (data input) as input data to the control system of CNC machine, and (3) simulate CNC program execution as animation of machine process in the CNC machine.

Problems in using virtual reality as CNC programming learning media are:

1. How is virtual reality development which can show the real environment visualization of a CNC machine on the computer screen?
2. How is the feasibility of the virtual reality as CNC programming learning media?

This article will explain; (1) building process of a virtual reality CNC which can perceive input and can react as the real CNC machine, (2) the result of that virtual reality CNC feasibility as CNC programming learning media.

Technology improvement, especially computer, should also be used in learning media. The using of computer in learning especially as interaction media and learning application, they are drill and practise, simulation, discovery, tutorial, problem solving, and games.

Computer use in learning activity, at least, has three purposes, they are cognitive, psychomotor, and affective. For cognitive purpose, computer can teach the concepts, principle, steps, process, and complex calculation. Computer is also able to explain that concepts simply by using combination of animated audio and visual so it will be suitable for independent learning.

For psychomotor purpose, computer is also able to serve learning process which is presented in

the form of games and simulation which are so good for creating work condition. Some examples are; simulation of aeroplane landing, simulation of war in the worst condition, etc. For affective purpose can be done when the program is designed well by giving sound or video clip which can be a trigger. Then, behaviour learning/affective can be done by using computer.

Generally, there are three kinds of simulation. One, interactive and physical simulation. Physical simulation refers more to the physical object simulation for replacing the real system. This physical object is often chosen for it is smaller or cheaper than real system or objects, as the flying simulator.

Two, computer simulation. Computer simulation is an effort to duplicate real situation in a computer, so the situation can be learned for watching how it works. By changing variable, possibility of prediction can be made about the behaviour of that system. Three, simulation in training. Simulation is often used in the civil and military training. This, generally, happens when the cost is high or it's too dangerous for allowing training participants to use real tools in the real world.

Simulation about real environment which is made by computer, and user can have interaction with the result which shows the content of reality environment is called virtual reality. Virtual reality is an human-computer interaction format where a real or imaginative environment is formulated and the users can be connected and run that world. In the most successful virtual environment, the users feel that they really exist in the simulated world and that their experiences in the virtual world is equivalent to what they experience in the real environment.

Virtual reality can be applied in many sectors. In the engineering and scientific research, virtual environment is used visually for identifying everything happens to the physical world that is in the observation. Training for work in the dangerous environment or with expensive tools is better done by using simulation. For example, pilot practises by using flying simulation. Virtual reality may let medicals for practising the procedure of new surgery to the imitation human.

One of the senses which is often used for getting information from the environment is seeing sense. Seeing sense is used more often than others in processing information. Many psychology researches show that there are more information can be understood when it's served in the visual form than in nonvisual form.

Training by using virtual reality can reduce the cost compared with common training. Need of expensive training tools in the real laboratory, or additional tools for training can be eliminated. The

advantages of using virtual reality as training tools are; (1) reducing duration of the training in the real environment, (2) can hold a training in the very dangerous condition, (3) save more cost to the same training, (4) providing unlimited access to the expensive tools, (5) omit the cost for going to the training center, (6) cost of repairing/replacing of expensive machines can be eliminated.

CNC (Computer Numerical Control) machine is a machine which of the operating process is controlled by CNC system, that is a control system which of the controlling is done by using command in the form of alpha-numeric-code. Set of commands in the alpha-numeric-code and used for controlling machine operation of a product is called CNC program.

## 2. Discussion

Development of CNC virtual reality is done by using research and development method. As the reference of development is CNC lathe machine training type EMCO, made by EMCO Maier Austria. CNC virtual reality is developed by using Visual Basic 6 software, with Windows XP Operating System. The result is a computer program which can present physical environment visualization of CNC machine on the computer screen. Physical environment of CNC machine which is displayed is control panel, monitor, and clamping of work-piece on the machine. Look at Figure 1.

View design of the control panel is made resembling to the control panel of CNC machine TU-2A. This aims the situation and feeling of the user is same as they are in front of the real control panel of CNC machine TU-2A. Besides feeling comfortable in using that also feeling the sensation of the challenge as they use the real machine.

Not all of the function of visualized panels and buttons on the control panel can be simulated, some are only images or accessory for giving sensation of reality and interactive sensation. Switch and buttons which of the function can be simulated are:

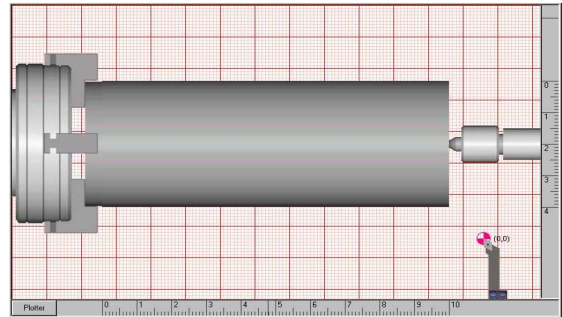

Figure 1. Display of CNC Virtual Reality on the Monitor Screen

1. Main switch. This switch can be simulated in two positions, those are "0" and "1" (ON/OFF). The function of main switch is for turning on and off the CNC machine.
2. Main spindle switch. This switch can be simulated in three positions, those are "0", "1", and "CNC". The function of the switch is for turning the main spindle whether in the CNC operating function and manual operation function.
3. Manually operating button, that is button for moving the chisel on the X and Z axis manually.
4. CNC operating button, that is Numpad for writing the code and number (NC program) which is made on the computer screen and put in the memory, and buttons functioned in the program editing, those are DEL for deleting written character, REV for moving the cursor to the previous line, and FWD for moving the cursor to the next line.
5. Start button, for starting running the written program.
6. Animation window, in this part, animation of chiseling is shown. Animation is constructed by some main components and supporting components. The main components are; (1) chuck, (2) workpiece, (3) live center, (4) and tools holder.

Typing buttons on the monitor screen (virtual buttons), those are numeric buttons "0" to "9", "INP", "DEL", "REV", and "FWD", can be functioned to write the CNC program on the virtual monitor. It goes the same as "START", and main switch ON/OFF can be operated identical to that button on the CNC machine. One of the excess of the developed product is being able to save written CNC program, recall saved program for being activated and shown on the screen.

Besides, written CNC program on the writing window of CNC program also can run. Written program is the input which can be processed into output. response or the output of the given input, is visualized as the run of CNC program reading by

machine unit control. The run of CNC program can be observed by simulating the move of slicing tools on the animation window on the computer screen.

Response from the input which is command (code) of CNC programming can be simulated by using animation of relative lathe chiseling to the work stuff. CNC programming code which can be processed and animated are still limited, it is limited only for command code which is often used in the beginning of making CNC program training for CNC machine TU-2A. Those command codes are: "G00", "G01", "G02", "G03", "G92", "M03", "M05", AND "M30". The animation result of the run of the CNC part program can be seen in the Figure 2.

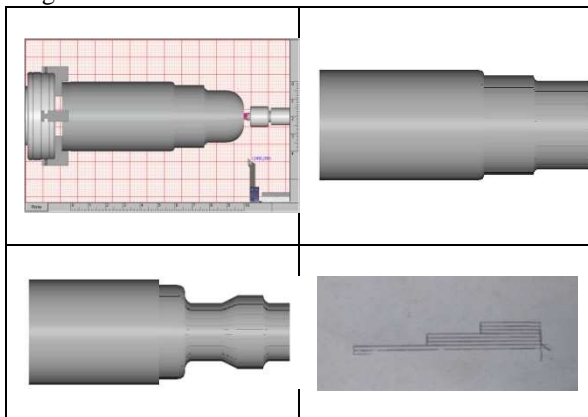

Figure 2. The Animation Result of the Running the CNC Part Program

Can be concluded that this research succeeded developing CNC virtual software, that is a computer program which can present the visual effect of CNC machine TU-2A operating principle on the computer screen. The program can initiate, translate, and respond to each input well. Respons (output) as the result of initiation and translation from the input in the form of command codes in NC program, visually in not different from the respons which is done by the real CNC machine if the machine system control gets the same input.

Although in the product development, especially the view is successful, the development produk has not been able to show the animation of program run for all command codes. Effort for developing translation of CNC program to the animation has been able to be made though it's limited to the some basic and simple codes, so the new product can be used for training basic CNC programming.

CNC virtual reality is able to fulfil the criteria as a learning media in two things; (1) product is able to give the image and visual effect of operational function of CNC machine so it can be a media which can give experience to the users, and (2) the product is able to explain clearly about the

concepts of learning materials so it can help the users in understanding learning materials well.

Based on the product criteria as the media which visualize CNC machine, it can be stated that the product has good view, especially the view format, matching shape and colour, and the suitability to the control panel of the real machine. Besides, the product which is developed is also easy to be used/operated, and be able to build interaction well between the users and used media. Therefore, the product can be a tools of making CNC program training, tools of direct interaction, and tools which let the users learn independently well.

Based on the criteria as the media which can help explaining clearly the concepts of materials, it's known that the product which of the materials are developed is able to explain clearly the concepts of materials well, for the visualized materials have suitability to the learning materials of NC Machine, for example the materials about programming code, and making NC program. Besides the suitability of taught materials, there is also suitability between the chisel moving animation done by the product to the real chisel moving in the CNC machine. This causes users become easier to understand materials of programming concept, for the concepts can be directly visualized by using animation on the developed product.

### 3. Conclusion

1. CNC Simulator with Virtual CNC which can show the physical environment visualization of CNC turning machine; control panel completed by accessories and operating buttons, clamping system of work stuff, lathe chisel, operation function simulation, and the animation of machine process from the executed NC program, be able to generate students individually to be active in making NC part program and running that NC part program on CNC virtual and CNC machine simulator whether inside and outside the classroom.
2. For being used as teaching aid of CNC programming, CNC simulator which is developed has completed the requirements as education media, for:
  - a. Having view quality, navigation, operating, being able to stimulate users to keep interacting with CNC virtual.
  - b. The contents of CNC simulator with virtual CNC are good, especially for the basic elementary of CNC programming. The quality of content, this media is able to show the simulation of tool-path as the result of the running of CNC part program on the basic program code, where the users are able to combine the program codes

- c. which is put in as well as they want for seeing the result of the given input.
- d. CNC simulator can be used as the teaching, learning, and training media of CNC programming in the class, individual, outside the classroom, and by e-learning.

#### REFERENCES

- [1] Arif S. Sadiman. (1993). Media pendidikan, pengertian, pengembangan dan pemanfaatan. Jakarta: CV Rajawali
- [2] Groover, Mikel P. and Zimmers, Emory W. Jr. (1984). Computer design and manufacturing. New York: Prentice-Hall International, Inc.
- [3] Oemar Hamalik. (1986). Media pendidikan. Bandung: Alumni
- [4] Hollebrandse, J.J.M. (1988). Teknik pemrograman dan aplikasi CNC. Jakarta : PT. Rosda Jayaputra
- [5] Rinanto, Andre. (1984). Peranan media audio visual dalam pendidikan. Yogyakarta: Yayasan Kanisius
- [6] Soenarto. (2005). Metodologi Penelitian Pengembangan Untuk Peningkatan Kualitas Pembelajaran. Departemen Pendidikan Nasional: Direktorat Pembinaan Tenaga Kependidikan dan Ketenagaan Pendidikan Tinggi (PPTK dan KPT).
- [7] Sommerville, Ian. (2003). Software engineering, rekayasa perangkat lunak. Jakarta : Penerbit Erlangga
- [8] Nana Sudjana, Ahmad Rivai. (2001). Media pengajaran. Bandung: CV. Sinar Baru
- [9] Taufiq Rochim. (1993). Teori dan teknologi proses pemesinan. Jakarta: Higher Education Development Support Project.
- [10] Team. (2004). Software testing guide book part i: Fundamentals of software testing. Software Testing Research Lab : <http://www.SofTReL.org>
- [11] Wen-Chai Song & Shih-Ching Ou. (2003). Using virtual reality modelling to improve training techniques. Taiwan : National Central University
- [12] Williams, Laurie. (2004). Testing overview and *black-box testing techniques*.

## BENCH VICE PRODUCTION LINE AS AN INDUSTRIAL MODEL IN POLITEKNIK MANUFAKTUR (POLMAN) BANDUNG

Gamawan Ananto<sup>1</sup>, Albertus B.Setiawan<sup>2</sup>

<sup>1,2</sup> Politeknik Manufaktur Bandung,

Jl. Kanayakan 21, Bandung 40135, INDONESIA

<sup>1</sup>gamawan@polman-bandung.ac.id, <sup>2</sup>bertoes@polman-bandung.ac.id,

### Abstract

Polman Bandung as a vocational education institution experienced in combining with real industrial works for the students, means contributing self funding operation costs as general concept. Polman acts as a real manufacturer through Industrial Service, Logistic and Manufacture Engineering Unit that roles as marketing function, purchasing & managing raw materials/ components storage and executing machining/ assembly. In addition to provide jobshops, a serial Bench Vice as a 'standard product' also produced. Since Polman machine layout reffers to process group they found obstacles for producing such Bench Vices efficiently and to reach ideal arrangement due to 'long transport lines' for Bench Vice components to be processed from one kind of machine to others.

In order to enrich industrial atmosphere, a 'Bench Vice Production Line Model' could be created. Several type of machines that will be used for its components could be put in one area/corner, where all related activites will be centralized. The students will learn not only processing skill, but also introduced to other PPIC related issues: the process layout, raw material preparation and 'in process' storage, managing the finished products and also controlling all expenses favour. With such production line model, the students who become professionals will be accustomed to work properly in workgroup, think wider to treat next process as 'a customer' and be a more responsible workforce. Moreover, this model may be implemented to a business incubator as its growth into a mature sub system that still in line with 'The Alternatives of Vocational Education Financing' spirit.

**Keywords:** production line, machine layout, PPIC functions.

### 1. Introduction

Politeknik Manufaktur (Polman) Bandung is a vocational education institution that experienced for years in combining education and real production activities for producing industrial needs. In general basic concept, these activities are made to follow a recent technological needs of industries and for self funding operation costs at the same time. Through their departments/ units, Polman acts as a real manufacturer. 'Industrial Service Unit' that roles as 'marketing function' makes contact and technical discussion with the customers, offers what customer want and initiates business contract. 'Logistic Unit' runs as a purchasing department and managing raw materials/ standard components storage, whereas 'Manufacture Engineering Unit' executes the machining & fabrication process and assembly.

The industrial services activities is a type of jobshops such as tool & die, jig & fixtures and special purpose machines. In addition to provide another type of jobshops, Polman produces a serial Bench Vice as well as a 'standard product'. As known, Bench Vice is an equipment for workpiece clamping in workbench, made of ironcasting for main parts and common steels for other components, as shown in Figure-01. There are

various processes needed for its components other than casting process, such as milling, drilling, dovetail milling for its main parts, and turning, turning with ball attachment, painting and final assembly.

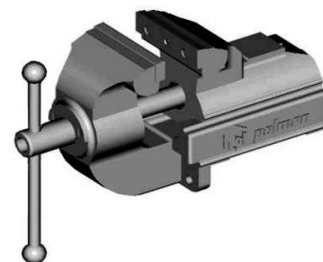

Figure 1. Bench Vice (Polman Engineering Document, 2010) [1].

Since there are fluctuative number of demand as a captive market, these Bench Vice products treated as jobshop too. Sometimes they found obstacles for producing such Bench Vices efficiently due to Polman machine layout that reffers to process group. Therefore difficulties to reach effective or ideal arrangement are occurred. There are long transport lines for Bench Vice components to be processed from one kind of machine to others.

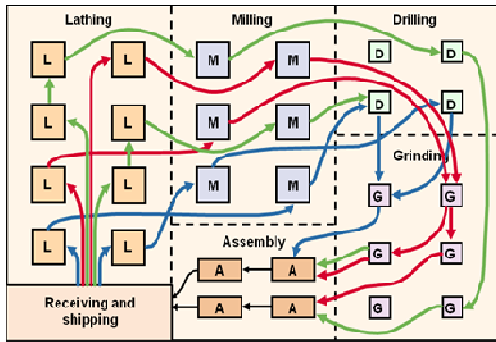

Figure 2. Jumbled Flows in a jobshop (Krajweski, Pearson Education, 2007)

Figure-02 shows an example from Krajweski [2] how number of materials or parts/ components flow from receiving till assembly in process group layout. For jobshop cases, this kind of layout has following advantages[3]:

- Flexibility. The company has the ability to handle a variety of processing requirements.
- Cost. Sometimes, the general-purpose equipment utilized may be less costly to purchase and less costly and easier to maintain than specialized equipment.
- Motivation. Employees in this type of layout will probably be able to perform a variety of tasks on multiple machines, as opposed to the boredom of performing a repetitive task on an assembly line. A process layout also allows the employer to use some type of individual incentive system.
- System protection. Since there are multiple machines available, process layouts are not particularly vulnerable to equipment failures.

Such layout seems not recommended for Bench Vice cases due to unmatch condition with advantages it has, Bench Vice production program is not variety product nor process and specialized machines or equipments may be used. In this case, the students will not be bored in Bench Vice Line since they have various kind of jobs that referred to their practice schedule program by rotation, either kind of activity (managing, machining) or type of machine process (milling, turning, etc).

## 2. Methodology

In order to decrease existing obstacles in Bench Vice production program and give more real industrial atmosphere to the students, a Bench Vice Production Line Model could be created. Several type of machines that will be used for Bench Vice components put in one area or corner. In this area all activities related with Bench Vice process will be centralized. Machines and equipments will be located referred to each component flow and operation sequence. Figure-04 gives an example of such layout with cells strategy. The students will learn not only machining and processing skill, but

also introduced to all related issues from the PPIC point of view: the machine/ process layout, raw material & components preparation and 'in process' storage, managing the finished products and also controlling all expenses favour.

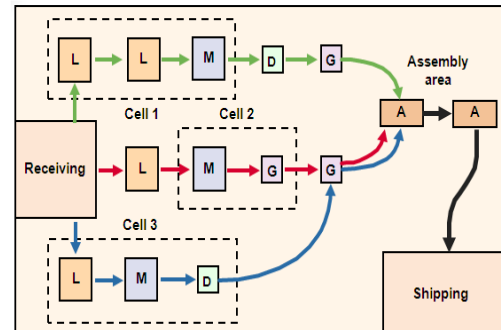

Figure 3. Line Flows with cells (Krajweski, Pearson Education, 2007)

As this model is treated like comprehensive small company, the students will be involved with planned schedule into all related activities in the production supply chain, these are all material and process planning (routing & dispatching), input receiving from warehouse/ logistic, execute the machining process included incoming check & outgoing check, assembly and finished product handling.

This Bench Vice Production Line will completing Polman workshop in fabrication and machining practice program for the students. Equipments and machines that re-located to special line will be separated from former jobshop activities, therefore students will be introduced to various of product handling. This line also makes better efficiency in bench vice components machining due to unnecessary activities decreasing.

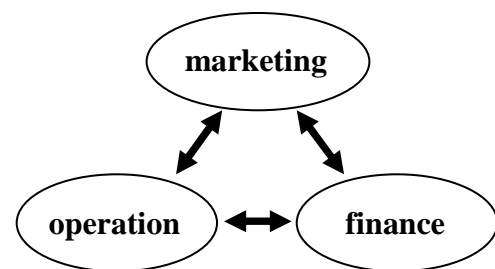

Figure 4. Company three ingredient functions[4].

In addition, Bench Vice Production Line is made for comprehensive exercise in manufacturing. From the real enterprise point of view, there are 3 ingredient functions that will be bonded each other as a frame: Marketing, Finance and Operation. In this production line of Bench Vice the students then will be pushed to take care of providing market demand properly, involved intensively in operation and take care of any actions that influencing cost or finance



consequence. In brief words they really be faced to essential production issues, either Quality, Cost or Delivery (QCD).

### 3. Result and Discussion

Such production line as an industrial model will enhance the perspective of students that become professionals in the future. They will be accustomed

to work properly in order not to 'stop' the continuous production line, think wider to treat next process as a customer, be a more professional and responsible workforce. Moreover, this model will be implemented to a business incubator as its growth become into a mature sub system, that still in line with 'The Alternatives of Vocational Education Financing' spirit.

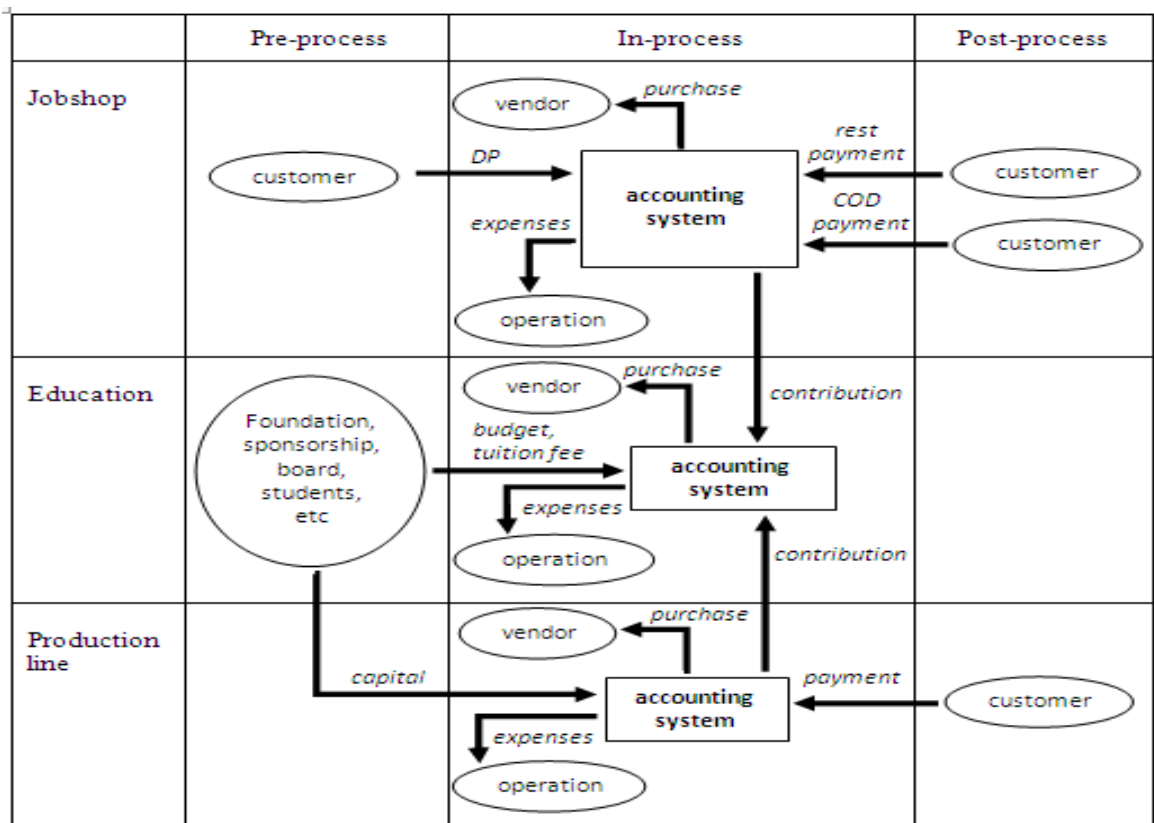

Figure 5. Jobshop and Production Line Contribution to Education Financing

Regarding education financing, the cost needed for vocational education program in many cases are 'nearly' higher than foundation, sponsorship, board budgetting and students tuition fee due to operational expenses for electricity, machine power and raw materials purchasing. Figure-05 simulates how jobshop activity contributes education funding from its accounting system. Production line do the same achievement but from different way in the matter of term of time, it is only in post-process when the goods are sold. With the period of time, this model could growing into a mature system and implemented to a business incubator.

### 4. Conclusions

Bench Vice Production Line is a good model in Polman for introducing real industrial atmosphere to the students in such vocational education due to comprehensiv activity, completing former jobshop program. Referred to basic and general concept of

industrial service activity program for the students, this also contributing self funding operation costs, and more alternatives of Vocational Education Financing is created.

### REFERENCES

- [1] Moerwismadhie, "Bench Vice Polman Engineering Documents" *Politeknik Manufaktur Bandung*, unpublished, 2010.
- [2] Krajweski, "Operation Management Chapter 8-9", [www.anekadownload.com/download/dl/process\\_layout\\_krajewski](http://www.anekadownload.com/download/dl/process_layout_krajewski), Pearson Education, 2007.
- [3] Encyclopedia of Business, [www.referenceforbusiness.com/management/Int-Loc/Layout.html](http://www.referenceforbusiness.com/management/Int-Loc/Layout.html), 2006.
- [4] Jay Heizer & Barry Render, "Operations Management", Upper Saddle River: Prentice Hall, 2006.

# CONVENTIONAL TO VIRTUAL LABORATORY IN VOCATIONAL EDUCATION

**Bernardus Sentot Wijanarka**

Department of Mechanical Engineering Education Faculty of Engineering  
Yogyakarta State University  
bsentot@gmail.com

## Abstract

Laboratories and workshops on vocational education is the primary facilities in the formation of student competence. On the other hand the operational costs to be paid to the implementation of practical learning is very high, so that vocational education institutions have problem in teaching and learning lab. There is always a gap between the ideal and reality in teaching and learning in laboratories and workshops.

The development of computer software technology is very beneficial to the teaching and learning process in vocational education in Indonesia. Huge cost in the purchase of equipment, lab maintenance, and purchase of lab materials will be reduced by using virtual laboratories or virtual workshop. At this time the virtual media can replace the real with the perfect condition. Expensive equipment, dangerous and complex operation can be replaced with a virtual environment that can reduce the cost and time. This article will discuss the use of virtual media in learning CNC machining for vocational education. The process of learning by using a virtual laboratory in several fields have been proven to enhance students' cognitive understanding, accelerate the learning process, and reduce costs.

**Keywords:** virtual laboratory, competence, vocational education.

---

## 1. Introduction

Learning process in vocational education requires adequate facilities and infrastructure. Standard facilities and infrastructure SMK / MAK which has been established with Permendiknas No. 40 of 2008 is a reference to create classes, laboratories and workshops. For vocational schools that do not have the laboratories and workshops, it is very hard to meet these standards, because it requires huge funds for investment. In the standard facilities and infrastructure, the virtual lab standards have not been listed. Virtual laboratory is a laboratory clone obtained through the use of computers and software. According to Sahin, et All (2008) the main advantage of virtual media use in the training are: cost savings, safety, and access flexibility.

The application of computer software technology in teaching and learning in some vocational education in developed countries has become commonplace. Technical Drawing lessons that previous using a drawing table, drawing machine, pencils, paper, has been changed to use drawing software such as AutoCAD, Solidwork, Corel Draw and so forth. The use of conventional production machines in the company have been very rare since been replaced by machines controlled by computers. From observations of the author in three medium manufacturing enterprises in Yogyakarta obtained results that for the production of machine components is almost 100 %

using a computer-controlled machines. On the other hand in many vocational high schools is still more to teach the operation of conventional machines, so there is a discrepancy between what is taught to what would be experienced by students when working later.

Facilities in most of the vocational school, particularly for machining competencies study program, at present using machining workshop containing a conventional machine tools: lathes, milling machine, drilling machines, grinding machines, and shaping machines. Some schools have more advanced machine tools and has used CNC (Computerized Numerical Control ) machining laboratory to practice the operation of CNC machines tools for their students. Problems that arise in learning CNC machining is what to teach and how to teach. In this article will discuss the use of instructional media in the form of CNC virtual machine tools or the use of virtual labs to form a vocational high school students' competence.

## 2. Virtual reality as learning tools

It can be argued that the ultimate goal of education, at any level, is to prepare the learner with the skills needed to succeed in life (Aldrich, 2002). To maximize their instructional effectiveness, career and technical education (CTE) programs need to apply effective Learning tools in their classrooms and laboratories. Recent literature



reviews of published research have consistently documented the effectiveness of virtual reality (VR) as a learning tool in a variety of settings. The research has shown that many educational institutions, industries, and organizations are now turning to VR to provide effective and cost-efficient ways of teaching and career preparation and development. The field most actively reported in the VR literature is medical/dental, where large numbers of published studies have attested to VR's benefits. Engineering has also reported considerable success with virtual reality instruction. Use of VR for both career training and for product development has also been reported for several years in a variety of other industries such as aerospace, petroleum, equipment design, vehicle prototyping, lathing and manufacturing, accident investigation and analysis, law enforcement, anti-terror response, hazard detection, crane driving, aircraft inspection and maintenance, and facilities planning (Ausburn, 2009).

The desktop virtual reality uses QuickTime, Java, or Flash technology to present high-resolution panoramic imagery on a standard desktop computer. Desktop VR "movies" are created by taking a series of digital still photographic images and then using special VR software to "stitch and blend" the images into a single panoramic scene that the user can "enter" and explore individually and interactively. The user employs a mouse to move and explore within an on-screen virtual environment as if actually moving within a place in the real world. Movements can include rotating the panorama image to simulate physical movements of the body and head, and zooming in and out to simulate movements toward and away from objects or parts of the scene. Embedded individual virtual objects can be "picked up," rotated, and examined as the user chooses, and clickable "hot spots" can also be used to navigate at will (Ausburn, 2009). What characterizes these desktop VR movies and distinguishes them from traditional video is that the user chooses where, when, and how to move, explore, and examine rather than being controlled by the prior production decisions of a videographer (Ausburn & Ausburn, 2004). Noe (2008:290) define the virtual reality as a computer based technology that provides trainees with a three-dimensional learning experience. Virtual reality allows simulations to become even more realistic. Using specialized equipment or viewing the virtual model on the computer screen, trainees move through the simulated environment and interact with its components.

Virtual environments provide safe and cost-effective environments for learning and "hands-on" training. Recent strides in computers and graphics cards speeds are making it increasingly more realistic (i.e. closer to physical environments)

especially from the visual and auditory perspectives. Accordingly, Virtual environments are becoming increasingly attractive in education and training applications (Wasfy, 2008). A recent review of the literature found that nearly half of the research studies on the development of products and tools dealt with computer-based or Web-based instruction (Richey,2009:20). The descriptions below are the example of CNC Machining training centers used virtual laboratories/ machine.

### 3. SinuTrain – the efficient SINUMERIK CNC training system

With the option "Virtual machine designed for training purposes", SinuTrain offers – through a 3D simulation of the machining process – reality-identical system operation increasing the efficiency of CNC training (Figure 1). This option allows to "manufacture" workpieces on the PC using reality-identical processes, on the basis of three implemented machine types – including one milling machine and two turning machines, one of these equipped with a counterspindle. The advantage of it is the customer need not buy expensive machines. When the machine purchase costs are too high on account of reduced budgets, the "Virtual machine designed for training purposes" is a low-cost alternative to CNC training.



Figure 1. SinuTrain Training

### 4. Emco Industrial training

TrainConcept is a multimedia training program that teaches all the basics of modern CNC technology. TrainConcept's cleverly-designed teaching format makes even complex concepts easy to grasp and learn. Interactive dialog features allow trainees to progress at their own pace. Views are displayed using attractive 2-D-graphics and 3-D-graphics, animations, and videos, taking the work out of learning and making lessons memorable. The course can be taken either on a PC or via an intranet or the Internet (Figure 2). TrainConcept is the ideal teaching platform. Videos can be moved, zoomed or slid. The software includes interactive 3-D-objects and users can move, enlarge and shrink

graphics using the mouse and the animations can be manipulated.



Figure 2. EMCO CNC Training

## 5. VTC for CNC

The Virtual Training Centre (VTC) was set up on the Internet for Computer Numerical Control (CNC) training based on virtual aids. A virtual space (a CNC training portal) on the Internet which allows the constant sharing of e-learning-based CNC teaching material was created so as to foster the further development of e-learning based CNC educational contents. The equipment, methods, curriculum and techniques currently used in CNC training by partners were observed, collected and evaluated. The selected materials were used to create the new and common curriculum on which this VTC was based. This curriculum was taken as the core of virtual training activity. Depending on this curriculum, an interactive teaching program was developed and put into a website to form a virtual training centre. The site, along with the interactive teaching program, consisted of four main areas: "News", "Exchange of Views", "Links", and "Resources". Thus, users will be able to access, to name a few, to the newsletter, a bulletin board, online surveys and survey reports, information on VET networks, an electronic library with references, a bookshop with downloadable publications and a number of databases.

## 6. LearnHaas.com : Virtual Training Environment CNC Machining

The Virtual Training Environment for CNC Machining combines powerful "flight-simulator" technology with a flexible Internet-based learning content management system to deliver a truly innovative learning experience. Unlimited access to train and rehearse in the Virtual Training Environment for CNC machining enables learners to develop greater confidence and proficiency prior

to performing actual procedures and operating equipment (Figure 3). Mill and Lathe CNC online courses provide the learner with comprehensive learning content, interactive exercises and virtual CNC panels and 3D machines.

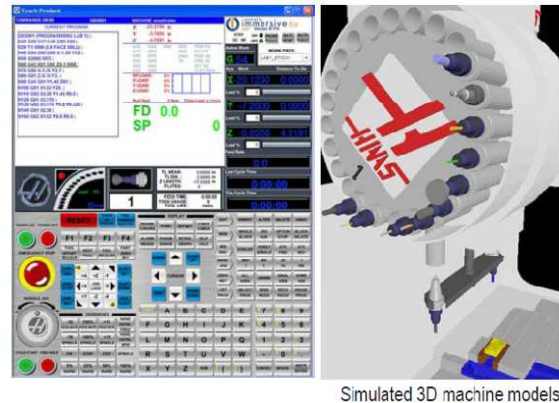

Figure 3. Interface of virtual CNC panels

## 7. Swansoft CNC Simulator and CNC Virtual Machine

Based on factories' manufacturing and colleges' teaching experience, Nanjing Swan Software Technology Co.Ltd developed the following software: FANUC, SINUMERIK, MITSUBISHI, GSK, HNK, KND, DASEN, and simulation software for CNC machine tools. Through which, we can attain the aim of enabling students to have the experience of practical manipulation on a largely-reduced cost (Swansoft, 2007). This software has the advantage of the machine control panel can display that functions like a real machine or virtual CNC machine tool. In addition the machine settings, selection tools, and workpiece clamping look like the real machine that is displayed on computer monitors. Swan series NC simulation software can be further divided in 8 major types, 28 systems and 62 controlling surfaces. Equipped with FANUC, SINUMERIK, MITSUBISHI, GSK, HNK, KND, DASEN software, swan CNC machine simulation software can help students to learn operation of CNC milling tool, lathe and machining center of each system.

## 8. The advantages of Virtual Laboratories

The virtual CNC laboratories can be used to provide hands-on training on the operation of CNC machines. The students can also experiment with the virtual machines and test operating procedures and CNC programs. Hands-on training and experimentation enhance students learning and retention and increase students creativity and problem-solving capabilities. In addition, the virtual CNC machine provides an effective knowledge capture and reuse capability. The traditional knowledge capture method of relying on operating

manuals fails to capture the dynamic and time-dependent aspects of operating CNC machines (Wasfy,2005).

Virtual CNC machines (Simulator) can attain the aim of enabling students to have the experience of practical manipulation on a largely-reduced cost (Swansoft, 2007). Simulations are best used according to Aldrich (2002) in three situations: (1) simulations can be used for developing ideas and concepts that which only experience can strengthen its understanding, (2) simulations are good for giving people practice in decision-making before they are faced with real-life situations that can be dangerous or critical, or for issues that deal with time or scale, and (3) simulations allow people to experience a time or place that they are unlikely to experience directly (Figure 4).

The three main advantages of Virtual training environments over traditional training on physical CNC machines are: (1) cost: the Virtual training environment runs on Windows and Linux based PCs. Thus, small colleges can provide CNC machining training without investing a lot of money to setup a CNC machining lab. Even for larger colleges, there could be budget limitations that prevent the initial investment (especially, for sophisticated machines) or the subsequent upgrading to keep up with the changing technology. In addition, the virtual machine saves money on consumables such as tools and workpieces, (2) safety: the students can experiment without risk of damaging expensive equipment and facilities or injury, and (3) Access: unlike manufacturing labs with limited lab hours and required supervision, the virtual CNC machine is easily accessible at any time without supervision and can be accessed via the Internet. Noe (2008:308) state that simulations and virtual reality is the best computer based training methods compare to the other. Simulations and virtual reality can improve the learning outcome (verbal information, intellectual skills, cognitive strategies, attitudes, and motor skills). Sim Tech (<http://www.SIMTech.a-star.edu.sg>) said that the use of virtual machining or training simulator can help educational institutes enhance the quality of their CNC training courses as well as reduce by more than half capital investment in CNC machines and training consumables. The benefits include lower capital investment and operational costs, elimination of injury risks and damage risks to machines, raw stocks and toolings.

## 9. Conclusion

Increasing the efficiency and effectiveness of learning CNC machining competencies in vocational high schools can be done by learning the practice of CNC Machine tools. Implementation learning for CNC machines tools can be done with computer -based learning method uses a virtual

CNC machine. The use of virtual machine has advantages: saves costs, save time training, safety, and can be accessed anytime.



Figure 4. Vocational High School students learn CNC with virtual CNC machine

## REFERENCES

- [1] Aldrich, C. (2002). A Field Guide to Educational Simulations. Alexandria, VA: American Society for Training & Development.
- [2] Ausburn, L.J., dkk. (2009). A Cross-case Analysis of Gender Issues in Desktop Virtual Reality Learning Environments. *Journal of Industrial Teacher Education*. Vol 46 No.3, hal 52-53.
- [3] Ausburn, L.J., & Ausburn, F.B. (2004). Desktop virtual reality: A powerful new technology for teaching and research in industrial teacher education. *Journal of Industrial Teacher Education*, 41(4), 33-58.
- [4] EMCO Maier Ges.m.b.H. (2010). Easy Learning, Easy Machining, from <http://www.emco-world.com>.
- [5] LearnHaasCNC. (2010). Virtual Training Environment CNC Machining. From <http://www.LearnHaasCNC.com>
- [6] Noe, R.A. (2008). Employee Training and Development. McGraw- Hill/Irwin : New York.
- [7] Richey, R.C, and Klein, J.D. (2009). Design and Development Research Methods, Strategies, and Issues. Routledge: New York.
- [8] Sahin, M, et al. (2008). Virtual Training Center for Computer Numerical Control. *Int. J. of Computers, Communications & Control*, Vol. III (2008), No. 2, pp. 196-203.
- [9] Siemens. (2008). Sinutrain CNC Training, Training and Programming on The PC. From [www.siemens.com/sinutrain](http://www.siemens.com/sinutrain).
- [10] Sim Tech. (2007). Leading Precision Engineering into Virtual Machining. <http://www.SIMTech.a-star.edu.sg>. June 27. Issue 50.
- [11] VTC. (2010). The Virtual Training Center VTC. From <http://www.vtcforcnc.com>
- [12] Wasfy, T.M, et al. (2005). Virtual Training Environment for A 3-Axis CNC Milling Machine. *Proceedings of IDETC/CIE*. September 24-28, 2005.

# THE PRODUCTION UNITS ORGANIZATIONAL STRUCTURE FOR VOCATIONAL HIGH SCHOOL IN THE FORM OF “KOPERASI”: DREAM OR SOLUTION?

Mila Mumpuni<sup>1</sup> and Widarto<sup>2</sup>

<sup>1</sup>Training Center in Yogyakarta- Branch of FETA, <sup>2</sup>Yogyakarta State University  
<sup>1</sup>Edelweis36@yahoo.com, <sup>2</sup>wied\_mesin@yahoo.com

## Abstract

This article is intended as a thought about the ideal form of organization for the Production Units. Production Units in Vocational High School aimed at three aspects: academic, economic, and social. In this article related to the economic aspect, the production would be sold to the market. We realized that the implementation of production units require a source of funds comes one of them from the government. Basically there are funds used to meet these three aspects. However, the Government provides funds primarily as a fulfillment of the academic aspect.

In accordance with PP No. 29 of 1990, Production Units is the business and professional operation. Production Unit to be able to compete in the market. Therefore, the economic aspect allows the production unit profit from selling the products. Production Unit revenue obtained legally entitled to full government. The rights of government called the Non Taxes State Revenue. While the Production Unit was formed also as efforts to provide extra income for teachers, students, school staff, and institution. During this dispute the legitimacy of the income earned can be used as income or as capital turnover business.

Therefore, the Production Units to be formed in a lawful organization to manage funds from government sources as business capital. Offered is a *Koperasi* organization is an association of some people is an enterprise for mutual benefits or profits. *Koperasi* in the form of legal entity as an alternative organization of Production Units. With formed into a *Koperasi* production unit hopes to further improve the quality of production, able to compete in the market, and able to provide welfare for students, teachers and school staff.

**Keywords:** Production Units, *Koperasi*, Governments.

---

## 1. Background

Educational institution always to be required to adapt and anticipate demands of industry. However, in Indonesia contribution of industry in the development of education has not been optimal. As a user of the workforce, the industry should participate responsibly to prepare the labor. Meanwhile, in order to keep Vocational High School (VHS) abreast industry needed a very large funding, and it is very burdensome by Vocational High School. From this conditions, based on Government Regulation No. 29 of 1990 about Secondary Education, the school as educational institutions were given the autonomy to explore and manage their own funds. In subsection 2 of this regulation mentioned that in order to prepare students Vocational High School became skilled labor, the school can set up production unit that is a business (profit oriented) and operate in a professional manage.

Production Units is one of the programs developed by the Directorate of Vocational High School (DPSMK) as one of the patterns of teaching in schools in order to match between the quality of graduates with employment skills needed by the workforce. Therefore production Units a tools for

vocational skills training should be managed professionally, related to the input, process and output.

According section 30 of Kepmendikbud. No.: 0490/U/1992 the indicator of professional management Production Units are (1) the learning activities on the real work that can produce goods or services for sale, (2) vocational teachers raising activities on the type of work that can produce the goods or services for sale, (3) pursue students' practical activities in the world of work, (4) seek internships for teachers in the workplace, (5) carry out maintenance and repair facilities in vocational education with the principle of self-management, (6) organize training activities that can provide services in return for the Vocational High School, (7) conducting joint production, marketing, and promotion; and (8) carry out service activities to the general public by utilizing the resources in schools that also can be a member revenue funding for schools.

From the indicators know that the objectives of the Production Units in Vocational High School are: provide opportunity for students and teachers working on market-oriented, encourage students and teachers to develop economic and



entrepreneurship, additional funds for education, improving resource utilization schools, and enhance the creativity of students and teachers. Therefore, the Production Units is a business that produces goods or services, so it absolutely requires a set of business tools as the main capital. The first question is what is the form an organizations such as whether the business entity that should be implemented for Production Units?

In the Guidelines for Implementation the Production Units of Vocational High School, Production Units was formed strongly associated with three aspects are academic, economic, and social. Academic aspects of the implementation the Production Units of Vocational High School related with the process of teaching and learning in schools. The economic aspects, Production Units dispose to make financial resources for finance education and improve the welfare of citizens of the school. While the social aspect is expected the Production Units can realize the main task of the intellectual life of the nation's education and to character building with an entrepreneurship. From the three aspects, economic aspects are need to get more in-depth study. What is that? Discuss of the economic problems very close relationship with funding issues. Funding the Production Units at Vocational High School should start with the source of the funds obtained, how to manage these funds, and how to account for these funds appropriately. Therefore, the second question is how to manage funds Production Units of Vocational High School safe, transparent, and accountable in accordance with the form of business entity or organization in Production Units of Vocational High School?

From description, this paper intends to discuss and provide solutions related to two fundamental problems with Production Units. The first what is the form an organization such as whether the match can be implemented? And how to manage the funds that are safe, transparent, and accountable in accordance with the form of organization? By obtaining the clarity of the two problems are expected to manage Production Units of Vocational High School safely in accordance existing regulations.

## 2. Discussion

Production Units is a process of business activities conducted in Vocational High School that are profit oriented. Production Units is managed by human resources at the school by optimizing school of resources. It implemented in various forms of business units in accordance with the ability to professionally managed. From the definition of Production Units is an ongoing business or activity in managing school resources to produce goods or services to be sold to benefit optimally.

Production Units objectives include providing opportunities to students and teachers to work on market-oriented employment practices and establish better relationships with business/ industry or other community facilities over the opening to the public. Production Units function to find and invent new ways, new breakthroughs in getting input from the business world, as well as process ingredients (inputs) into goods or services (outputs) and as a possible business development can create jobs so as to get the used or perceived by others. In other words, it can make a change of mindset school citizen actor to develop professionally so that products can be accepted industrial markets. Production Units in addition to developing the quality of goods or services also improve the quality of students. If students are capable of high-quality measured the working world can receive them.

Further benefits of Production Unit can be economically and educative. The economic benefit of Production Units are expected to increase school revenues moving towards a more independent, adding to the source of the operational costs of education practices in schools, increasing the number of teaching and learning facilities in schools, increase income for teachers and staff, and creating jobs for the community school. Production of goods or services produced by a Production Units can be sold to the public. quality of product is very influential in selling the product. Proceeds from sale of products should be administered again as a turnaround effort. The problem of funding sources largely sourced from the government. Accountability for the use of these funds entirely to the government, as well as profits of Production Units. Based on this, the benefits to be achieved by giving up welfare for the citizens of the school (teachers and students) will be hampered.

Production Units in Vocational High School, in principle, can make choices that best suit the purpose of the one. If it want to know customers closer who are in the area can build a "Koperasi" which can be an alternative option. The form of "Koperasi" organization as a legal entity to protect the school in managing resources from government to be optimized as the carrying capacity of the learning process as well as train the entrepreneurial spirit of goods or services resulting from the Production Units.

As we all know that the Koperasi is a business entity consisting of persons or legal entities with the bases of its activities based on the principle of cooperation as well as a popular economic movement based on the principle of the family. Cooperative aims to provide welfare for its members. Production Units can increase welfare for the people in the school environment and outside of

school legally on professional management of each Koperasi's members.

Production Unit can be categorized as a type of producers' Koperasi. Producers' Koperasi is an organization whose members have an identity as the owner and service users. In its capacity as a producer Koperasi's member producers to process the input into output produced a profit by exploiting the existing market. Koperasi's task is to fight for the profits from the members can be increased by up to marketing of the production process involves members so that profits can be enjoyed by members.

As with any other form of legal entity, to run Koperasi business activity requires capital. The cooperatives are the equity capital and loan capital. Own capital sources of capital include the following: (1) the principal savings and (2) compulsory savings. Principal savings is the amount of money that must be paid by members to the Koperasi at the time of entry be a member. Principal savings can not be retrieved as long as they are still the member of the Koperasi.

Deposits principal amount equal to each member. Mandatory deposit is a certain amount of deposits that must be paid by members to the Koperasi within a certain time and opportunity, for example every month with the same amount of savings for each month. Deposits shall not be taken back as long as they are still the member of the one.

Besides the capital can be sourced from: (1) The reserve fund gained from the preliminary balance of the business, which is intended for fertilizing their own capital, distributions to members that out of the membership of Koperasi, and to cover losses of the one if necessary; (2) The Grant the form of money or capital goods can be valued by money received from other parties who are grants/gifts and are not binding. Equity loans can be sourced from other parties that are binding or Koperasi may issue the bonds. Production Units as a Koperasi sourced funds from the principal savings and mandatory savings's members but contributions provided by government can be included as a grant. The Grants are not binding, do not need to be returned to the government but its use is legitimate.

Members of Koperasi consists of the internal school community and are entitled to income derived in accordance with the contribution to the existing's Production Units. This means that if a passive member invests only a different course with a member who actively contribute to the management of Production Units in the form of Koperasi.

Teachers can choose a passive member with enough invested in the form of principal savings and mandatory savings. Teachers can also act as an active member as the manager of Production

Units in producing goods or services. Students will automatically take an active role during practice at the Production Units. Both students and teachers are entitled to earn money for their active role in the Production Units.

Production Units in the form of Koperasi will have positive consequences can compete healthily in industrial markets for goods or services. Therefore, it must do duty as the Entity in accordance with tax regulations. Entity is a group of people or capital that is union, whether doing business or businesses do not do that includes them is Koperasi.

Obligation of Koperasi as the entity is as taxable person. The Koperasi is one of the taxable person in accordance with Law No. 38 of 2008 on Income Tax. Obligations of the one as taxable person are: (1) the obligation to register to get the Tax Payer Identification Number as an identity, (2) the obligation to keep accounting records in an orderly manner and in accordance with accounting standards on Koperasi, (3) calculate and pay taxes properly, (4) fill out and include the Annual Tax Return and Tax Return Slip; and (5) collecting and / or cutting taxes. Production Units as a consequence of Koperasi should do the bookkeeping as well as corporate taxpayers. This is a new thing possible for the one, but this is part of a change management professional in it. If it can show as the taxpayer person then the industry will see it as a competitor in the industrial market.

The Koperasi are classified as small businesses for one year if the delivery the taxable goods and/or taxable services with the amount of gross income or gross receipts of not more than Rp. 600,000,000,- (six hundred million rupiahs). The one are not required to report its efforts to be confirmed as a Taxable Person for VAT is not obliged to collect, deposit, and report on VAT or Value Added Tax and Sales Tax on Luxury Goods payable on delivery of taxable goods or Taxable Services done. Production Units legally given the option to voluntarily be confirmed as the one The Taxable Person for VAT is a businessman who conduct delivery of taxable goods or rendering of taxable services which are taxed pursuant to Law No. 42 Year 2009 on Tax Value Added. The advantages as the one is (1) the selling price will be lower because the input tax can be credited, and (2) the investment period, the input tax is creditable even though there has been no surrender.

Production Units in the form of Koperasi unconscious will bring major changes in organizational structure. The establishment aims to legalize the process of managing funds from government sources. Funding from government sources categorized as grants to cooperatives. Consequences of a grant is not binding so do not be returned back to the government. Similarly, the

government is not bound to give grants to cooperatives. Cooperative supposedly able to manage well the resources that exist both equity and loan capital. Legalized manage funds from the government in the form of cooperative organization will facilitate reaching economic benefits of giving up teaching entrepreneurship and increase the welfare of students and teachers.

The changes in the form of organization will bring up the taxpayer person of the consequences because the Koperasi are classified as entity. Therefore, It needs human resources requires the ability to do the accounting. This is done as reporting to the Directorate General of Taxation, both during and on an annual basis. This is likely to be burden some but it would be beneficial for the Production Units because the goods or services produced can compete freely in the industrial marketplace. Furthermore, if the it vote or have potential as a taxpayer for VAT. It will as an industry are taken into account in a healthy industry competition.

### 3. Conclusion

Establishment of Production Units in the form of Koperasi is used as an alternative choice for Vocational High School. Production Units in the form of one security for the managers will make up in managing the resources that exist in particular sources of funds from the government. If the goal of Production Units was limited to practice for students learning, the Koperasi organizational form do not need to be selected. However, if the Production Units also aims to make products competitive in the industrial market and the impact on the acceptance of benefits for the cooperative Production Units can be used as a solution.

The solutions that require changes in mindset and action patterns of the entire school community, both teachers and students. Citizen Schools was formed in the collection of people who are members of Koperasi. Each Koperasi's member has an obligation to contribute to both passive and active. Also required cooperative managers who are able to do bookkeeping as a consequence of the taxpayer person of entity. It possible solution would be burdensome for the citizens of the school but the change does require sacrifice. From the sacrifice of the fulfillment of obligations as a taxpayer and the entity for the protected.

The establishment of Production Units as a Koperasi need to realize the carrying capacity of the Ministry of Koperasi and the Ministry of National Education. The rules of the Ministry of Finance fully supports through taxation rules. If support is not obtained entirely for the one as a Koperasi; it will be only a "dream" in the future. The quality improvement will only be limited in the learning process for students only but not able to penetrate the outside wall of the school that is the industrial market. A dream or a solution, all depends on appropriate policies.

### REFERENCE:

- [1] Government Regulation No. 29 of 1990 about Secondary Education
- [2] Kepmendikbud Republic No. 0490/U/1992 about Vocational High School
- [3] Guidelines for Implementation of Production Units in Vocational High School, 1994.
- [4] The Law No. 36 of 2008 about Income Tax
- [5] Guidelines for Koperasi's Tax Policy, Deputy of Finance, Ministry of Koperasi and Small and Medium Enterprises, 2008.
- [6] The Law No. 42 of 2009 about Value Added Tax
- [7] The Rules of Minister of Finance No. 68 of 2010 about Limit Small Value Added Tax

# THE ENTREPRENEURSHIP TRAINING MODEL FOR BAMBOO WASTE HANDY CRAFT PRODUCT WITH BATIK DESIGN FOR SCHOOL DROPOUTS IN KLATEN DISTRICT, INDONESIA

Prof. DR.Hj.Rahmawati, M.Si, Ak. Dra. Anastasia Riani S, MSi. Dr. Asri Laksmi Riani, M.S.

Economics Faculty Sebelas Maret University Surakarta Indonesia.  
eahmaw2005@yahoo.com

## Abstract

The Implementation of Tri Darma University devotion through three communities was conducted through the analysis of training needs, based on entrepreneurship training, job placement and guarantee. The Appropriate goals for community services are, first, to provide the opportunity for participants in order to increase the time of knowledge, skills and mental attitude to the needs/market opportunities and job placement work on the business/industry). Second, to transfer the development of bamboo handicraft Batik on handy made with the participants to build partnership networks in order to facilitate the participants who have more control in Batik Design. Third, to educate and train residents in areas that suits the needs of the functional skills in the practical work to take advantage of both non-formal and informal sectors in accordance with the employment opportunities (Job Opportunities). This community service is funded by DP2M DIKTI DEPDIKNAS Indonesia.

**Keywords:** batik design, bamboo handicrafts, training.

---

## 1. INTRODUCTION

### BACKGROUND

Klaten district has an area of 65,556 hectares comprising 26 Sub-Districts and 401 villages with a population of the Village in 2007. Total of 1,972,740 inhabitants, the economy Klaten is 46.95%, demonstrated by the use of land amounting to 30,779 ha for rice fields and 53.05% (34,777 ha) for non-wetland.

Data in August 2008 showed the number of Indonesian labor force of 111.4 million people. Of this amount recorded 9.42 million (8.48%) people, are openly unemployed who live in rural areas 4,186,703 people (44.4%) and 5,240,887 people in urban areas (55.6%), then the poor Indonesia has reached 34.96 million people (15.42%) with the composition of 22,189,122 people (63%) were in the village and 12,770,888 people (37%) in the city. Therefore, it is necessary efforts to reduce unemployment and poverty both in urban and rural areas.

If viewed from an educational background are the unemployed, 27.09% down elementary education, secondary education 22.62%, 25.29% had high school, 15, 37% and 9.63% educated vocational education diploma to a degree. Related to the quality of education needed a helping hand from Higher Education in accordance with Tri Darma University is devoted to the community with efforts to educate and train local residents as needed to master the functional skills are exploited for practical work in both the informal and formal sectors in accordance with job opportunities.

Factual issues face by communities in Klaten area today is the problem of the large number of poor people whose urgently need immediate recall alleviated poverty will lead to social disintegration and insecurity. Conditions of poverty experienced by residents in Klaten area is basically caused by low levels of education, lack of knowledge and skills to try to close a large extent.

Partners in science and technology activities are school dropouts in Sumber Trucuk Klaten district. In accordance purpose Community Service provides opportunities for participants of childbearing age to increase the knowledge, skills and mental attitude in accordance with the needs/opportunities for the labor market and job placement in the business/industry (Dudi), for the development of Batik Design transfer to the participants carried out by building networks partnerships in order to facilitate the participants deepen mastery Batik Design and to educate train local residents as needed for control of functional skills which are utilized for practical work in both the informal and formal sectors in accordance with job opportunities.

## 2. EVENT PARTNERS

Science and technology activities for the community partners are dropping out of school children in the village of Sumber, District Trucuk Klaten district. In the village there are quite a lot of sources (about 100 people) of school dropouts aged 15 to 25 years, who does not have a regular job. They still follow their parents mostly as farmers.



The condition of school dropouts will become a burden for families/parents, if not soon get their own jobs. Creating employment by empowering skills that have become an alternative. In the village there are many Sumber Trucuk district craftsmen duck made from bamboo. Bamboo ducks are sold alongside a road Solo-Yogyakarta, Klaten Ceper precisely in the area during this is very exciting consumer interests, particularly foreign and local tourists who pass through the area.

Children drop out of school later expected to be workers who participated duck ornament craftsmen that still exist. Potential duck bamboo products will be enhanced by creating a more attractive design (painted with batik designs), which was shaped just duck bamboo duck and in the paint alone, will be upgraded into have been batik ducks from bamboo material. This certainly would be a more attractive commodity and higher economic value. With a selling price much higher.

Through training programs/training for school dropouts partners on technology batik made from raw bamboo, they would be power that has better skills and are able to create and improve products that attract consumers during these tourists but not/less attention development. This training is the idea of college teams that synergized with the program from the village headman Sumber Trucuk districts who want employment and want to increase revenue sluggish duck ornament craftsmen.

### **3. MEANING OF ITS EXISTENCE TO THE ENVIRONMENT**

Children drop out of school which has not had sufficient skills to empower themselves and to create their own jobs, following training programs on systems and technology batik made from bamboo, and attended various other training materials, such as entrepreneurship training which aims to instill the mental attitude of independence and instill creativity, cooperation, effective communication, as well as training finance/accounting, then the training participants consisting of school children will become self-sufficient and capable of entrepreneurship into the duck bamboo crafters creative with the technology they have learned (making a duck batik bamboo).

With the partners in considerable amounts in the village district Sumber Trucuk, trainees are expected to expand its business and to develop the skills they have acquired to their environment, so that the business environment in the region will be developed. With the development of the existing business is expected later can cultivate the economy in rural areas such Sumber.

#### **PROBLEM PARTNER**

From the background mentioned above, the problem is formulated as follows:

1. Partners who are school dropouts in rural districts Sumber Trucuk most have relatively low levels of education, as children drop out of school. Partner with school dropouts are also not yet have the knowledge, technical skills, and business management are adequate.
2. Partner school dropouts do not have the financial and mental capital that is sufficient to empower themselves to be independent and have adequate business. Thus with the skills that are supported by the available in Sumber village can be exploited. Craftsmen duck decoration can be a dealer and give jobs to children dropping out of school.

#### **PURPOSE OF ACTIVITY**

The purpose of this activity are:

- a. Improving the skills of learners (school children) to plan and manage the business ornate batik duck designed so as to obtain a decent income to make ends meet.
- b. Cultivate insights from the entrepreneurial spirit among the participants that have a high work ethic and can produce excellent works that can compete in the global market.
- c. Improving the ability of learners in managing natural resources, social, cultural, and environmental and able to take advantage of various technologies and designs in the business of craft decoration duck.
- d. Having the ability to understand ourselves, others and the environment and the ability to work in teams in both the formal and informal sectors in a professional manner.

#### **4. METHOD**

Of the issues that have been proposed, alternative solutions offered for the partners of school dropouts in rural districts Sumber Trucuk to be able to act independently and can be started the business with skills/adequate skills are as follows:

1. Required training/training system design technology batik on duck ornament made from raw bamboo.
2. Training mental attitude to entrepreneurship development.
3. Training/financial management training for participants.
4. Training Business Plan preparation for the participants.
5. Training Business Management.
6. Success Story by presenting relevant business practitioners.

It required a variety of designs that include the implementation of activities, evaluation, and implementation of activities is as follows:

### 1. Design Implementation Activities:

- a) Preparation includes activities undertaken.
  - Develop materials and instruments for selection and recruitment for trainees.
  - Coordination with relevant stakeholders, such as village government agencies or private resources and institutions/crafters duck already exist.
  - Coordination with the teaching team that includes professors from the University Eleven March relevant and of related technical practitioners, namely Mrs. Muh. Sahid, leader of the company CV. Morinda Karanganyar.
  - Preparation of materials/modules/training materials.
- b) Recruitment:

Participants who attend as many as 20 people who came from the child/youth dropping out of school in the Sumber village with efforts to open opportunities and overcome the constraints faced. Entrepreneurship Training for participants to give an opportunity for Children Dropout in competing or ready to work. Community Services has also recruited several partners from among the government agencies and institutions to institute private property as a form of cooperation in reducing unemployment.
- c) The provision of training: training provided, in the form, in-house training or out-house training.
  - a. Entrepreneurship training: provided by the University Lecturers Eleven March in the form of in-house training or out-house training.
  - b. Technical training, the manufacture of products made from bamboo ducks with batik design, which is given by technical practitioners from related businesses, Ms. Muh. Sahid, leader of the company CV. Morinda Karanganyar.
  - c. Financial management training in the form of practical training, preparation of business plans, management of the business is done in in-house training, by Lecturer Faculty of Economics, University of Eleven March with the help of students of the Faculty of Economics UNS.
  - d. Success Story speaker practitioners in the field of business-related.
  - e. Production technical assistance, business management, financial management, and to the formation of business networks for marketing products in the future.

### 2. Evaluation activities: after attending training activities and training of a whole series of materials, participants will be evaluated:

- a) At the end of the training program, participants individually required to make product training results in the form of batik duck made from bamboo.
- b) At the end of the course participants must demonstrate the practice of preparing the financial statements, management of the business.
- c) At the end of the training program participants are asked to submit business plan that will be made in writing or delivered orally.
- d) Presenting entrepreneurs associated with the scope of business partners locally, regionally, as well as export-oriented production to see the results of the participants in order to form business networks that will be done.

### 3. Implementation activities are:

- Lecturers related materials from the Faculty of Economics and the Sebelas Maret University.
- Technical practitioners from related businesses, Ms. Muh. Sahid, leader of the company CV. Morinda Karanganyar.
- Practitioners of related industries.
- Agency or village government Sumber as a device that has the competence in HR-related training participants.
- Craftsmen (SMEs) made from bamboo ducks that still exist and have the prospect of business development.

### TARGET

1. Objective criteria Educate Participants
  - a. Have an interest to learn/do business on Batik Design.
  - b. Productive age population (18-35 years) women and men, who come from disadvantaged families/poor.
  - c. Minimal educated SMP/package B or the equivalent, high school dropouts or high school graduates do not continue.
  - d. Location is in the Trucuk village Klaten district.
2. How to Educate Participants Recruitment
  - a. Socialization Dissemination to citizens in Countryside Sumber Trucuk Klaten district with materials dissemination of Community Service from the Sebelas Maret University Surakarta.
  - b. Announced to citizens in Countryside Sumber Trucuk Klaten District of Entrepreneurship Training will be held and opened registration for prospective participants.

- c. Selection Conduct the selection of registration under criteria which have been defined.
- d. Placement Establish a list of participants who have been selected.

#### LEARNING STRATEGIES

Learning process implemented in the following manner:

- a. Groups.  
For purposes of efficiency and effectiveness of learning strategy performed with a model approach to the group through the formation of 4 (four) groups each 5 people, a total number of students 20.
- b. Andralogi approach.  
Personalized approach based on individual needs and abilities of students with an approach that leads to minimize instructional approach.
- c. The ratio of theory and practical subjects is 20% compared to 80%.

#### PLACE OF EXECUTION

Place of implementation of Community Service Entrepreneurship Training for Children Dropout at the Village Sumber Trucuk Klaten Regency and CV Morinda Karanganyar. This event was attended by as many as 20 residents to study participants.

#### TRAINING CURRICULUM

##### 1. Learning Materials

Subject matter provided in the Entrepreneurship Training for Children Dropout includes four substantive skills include: Skills of Personnel, Social Skills, Academic Skills, and Vocational Skills. Given the subject matter of each of these substances from the group consisting general subjects as well as supporting a theory of subjects while learning skills is the subject practice. The training is conducted within the frequency of meeting times and duration of each meeting is 100 minutes.

## 5. RESULTS AND DISCUSSION

#### TARGET outcomes:

Target outcomes of this service are:

1. All participants of the training make bamboo products made from raw duck with batik designs.
2. All training participants able to prepare the business plan/business plan that science and technology based.
3. Most participants (60% of participants) are able to realize their business training into real business.
4. After the training the participants can open Independent Business. Of the 20 people the learner, all can work on the CV. Morinda. As

for the job in order to do their own home. The work provided in accordance with the order of CV. Morinda Karanganyar.

To be well targeted training activities carried out with the involvement of technical resources persons namely: Mrs. Muh. Sahid, leader of the company CV. Morinda Karanganyar. For purposes of efficiency and effectiveness, the practice is not done to each of the learners will be but done to the 4 (four) groups. At the end of the implementation of training activities carried out evaluation of training conducted in cooperation with the CV. Morinda Karanganyar. Training includes the practice of the technical production of bamboo Batik Design, technical planning and managing new ventures and preparing business bookkeeping. Assessments carried out to build a marketing network for trainees Batik Design by CV. Morinda. CV. Morinda often receive orders from domestic and abroad to handycraft so hopefully the 20 participants who can complete a given job. With the training through Community Service is expected to be skilled and residents learn to work in accordance with market demand so that will get maximum results, revenues that will be accepted based on how much can be finished more and more to get the job done more and more wages received. For example, to do handicraft form of bamboo duck (duck have been batik) before have been batik price of Rp 5000, - (five thousand rupiah) after have been batik price to 15,000, - (fifteen thousand rupiah) so that an increase of 300% and the results are quite encouraging for the participants of the training. In a day to do 10 pieces, for a month to do 300 pieces not yet have been batik. Price before have been batik: @ Rp 5.000, - (300 X Rp. 5.000, - = 1.500.000, -) if after have been batik sold at @ 15.000, - (300 X 15,000, - = Rp. 4.5 million, -) then, within one month of his income is above the minimum wage. Therefore, this training can improve living standards for people, especially the training, and income may increase as well.

#### Assistance Activities

1. The purpose of Mentoring Activities  
Provides advocacy and technical guidance to students in understanding the knowledge and skills acquired during training and apply them in business and industrial world as well as work independently.
2. Material Assistance  
Assistance in the form and technical assistance which includes three aspects:
  - a. Batik design on duck ornaments made from raw bamboo.
  - b. Planning and management of entrepreneurial businesses and entrepreneurship.

c. The basics of management and bookkeeping.

### 3. Instructor Mentoring

Instructor assistance is a faculty member of the FE UNS and experts as much as 3 people and assisted students.

### 4. Mentoring Model

Mentoring is done by using a model of participatory approaches in the field is through the full participation of the instructor assistance in activities of learners. Mentoring is done by a strategy group that is assisting the 4 groups of 20 people who formed the learner training. Each group consists of 5 students is 4 people as members and one student selected as the head of the group.

### 5. Time and Place of Assistance

Technical assistance for training learners batik design on duck ornaments made from raw bamboo for the poor residents in the Village District Sumber Trucuk Klaten regency was held on October 29.30 and 1,2,3,4 November 2010 with a frequency of 5 times to visit the instructor mentoring each group and one-time evaluation.

### Implementation Assistance

The instructor team visited each group and identifies problems encountered and provides solutions to these problems by providing explanations for the difficulties experienced learners in the process of designing batik as well as the process of finishing the decorations made from raw bamboo ducks.

Assistance Team provides direction and guidance to get good-quality materials, by providing examples and application usage and demand for smooth production.

At the end of the meeting held evaluation for learners to determine whether students are able to produce products according to standard or as a selection for the receipt or not the products/results of batik designs on ornaments made from raw bamboo ducks that will be ready to work.

If the evaluation turns out there are not as expected then the team will make allowances when giving guidance to students able to produce standard products and are ready to work.

#### 1. Implementation Program

##### a. Preparation Phase

Preparation phase which includes the stage of selection and recruitment of students and instructors have been made on time according to the schedule proposed were in September 2010 with the achievement of objectives to meet the criteria as planned.

### b. Training Phase

Implementation of the training was held on October 8,9,15,16 2010 with the funding allocation within the budget. Target training has effectively been achieved as indicated by the indicators of good learning materials evaluation theories on business management skills as well as material that is practical skills of batik design on duck ornaments made from raw bamboo for students who show an increase in competence.

#### 2. Benefits Institutional

Efforts application of science and technology developed have contributed to increasing the participation of FE UNS in order to improve the quality of life of rural poor in education, in economic, social and cultural.

#### 3. Social Benefits

Implementation of education and training activities batik designs on ornaments made from raw bamboo duck which was held is the provision of contributions towards the development and improvement of human resources for citizens in the Village District Sumber Trucuk Klaten district so as to change their behavior from people who have never been the business/entrepreneurship into independent and more business managers become managers or work more professional.

#### 4. Economic Benefits

Application of technology batik designs on ornaments made from raw bamboo ducks in education and training for citizens has given added value in the form of skills Batik Design On bamboo additional impact on increasing income. For example: before training, residents have never made batik design on duck ornaments made from raw bamboo. Who made the daily duck decoration is cheaper than in the have been batik. The selling price is for decoration duck @ Rp. 5000, - (five thousand rupiah) whereas if after have been batik price of Rp. 15.000, - per piece. So that residents receive significant revenue because the price of duck ornaments made from raw bamboo designed batik is more expensive and rather encouraging for students.

### Suggestion

To further improve the effectiveness of future training is recommended for:

1. Improving the quality of inputs (people learn) that by including in the candidate selection criteria to learn that residents who have the potential to entrepreneurship and has a strong willingness to the business of batik design on duck ornaments made from raw bamboo as its main business and not a side business. Consistently designs developed in the direction of training for participatory training design through the adjustment of the exercise content to the needs of participants, participant comprehension and presentation of

2. material that allows participants to participate actively.
3. Develop training design model that includes analysis of training, implementation, training and evaluation of training, so that learners can acquire new skills, knowledge and attitude in training but also be able to apply on the job.

#### Implication

1. Batik design field training program on duck ornament made from raw bamboo for the poor residents in the Village District Sumber Trucuk Klaten district are expected to successfully change the behavior of participants in carrying out their work as expected so that a transfer of training can be implemented properly. Transfer of training is defined as an ongoing activity to apply the expertise, skills and attitudes gained from the training.
2. By considering the benefits of training programs in the form of batik designs on ornaments made from raw bamboo duck encourage citizens to learn to work more professionally, it can be replicated to a group of citizens who do not get a permanent job or who are still unemployed.
3. In the future can be done a study to measure the effectiveness of the "transfer on training" that will be known who carried out the extent to which training can change the behavior of students who were involved in the business and industrial world as well as those trying to independently.

Furthermore, for studies that will identify the factors that influence the success of learning and transfer (generalization) training is expected to be able to provide the management direction of better training in the future.

#### REFERENCE

- [1] Adi Nusantoro, 2002, Memberdayakan Ekonomi Rakyat Untuk Pembangunan Ekonomi Indonesia, **Jurnal Ekonomi dan Bisnis**, UGM, Yogyakarta.
- [2] Anju Dwivedi, 2004, Metodologi Pelatihan Partisipatif, Penerbit Pondok Edukasi, Yogyakarta.
- [3] Agus Suryana, 2005, Seni Mendesain Pelatihan, Penerbit Progres, Jakarta.
- [4] Agustien Nyo dan Endang Subandi, 1999, Pengetahuan Barang Tekstil, Direktorat Pendidikan Menengah Kejuruan, Departemen Pendidikan dan Kebudayaan.
- [5] Ferdinand Agusty, 2003, Keunggulan Diferensiasif Dan Kinerja Pemasaran, *Jurnal Bisnis Strategi*, Fakultas Ekonomi Universitas Diponegoro, Semarang.
- [6] Genova, 2002, Mengenal Lebih Dekat : Kewirausahaan, *Jurnal Ekonomi Perusahaan*, STIE IIBI, Jakarta.
- [7] Geoffrey G Meredith, 1996, Kewirausahaan Teori dan Praktek, Pustaka Binaman Pressindo, Jakarta.
- [8] Gist: Bavetta & Stevan, 1990, Transfer Training Method: Its Influence on Skill Generalisation, Skill Repeetition and Performance Level, *Personel Psycology*.
- [9] Hall, C. M. 1996. Special Interest Tourism: an Introduction to tourism. Melbourne: Longman.
- [10] Handari Nawawi dan Mimi Murtini, 1996, Penelitian Terapan, Gajah Mada University Press, Yogyakarta.
- [11] Husein Umar, 2002, Metode Riset Komunikasi Organisasi, Penerbit PT. Gramedia Pustaka Utama, Jakarta.
- [12] Jusuf Irianto, 2001, Prinsip Prinsip Dasar Pelatihan, Insan Cendikia, Jakarta.
- [13] Jumaeri et.al, 1994, Tekstile Design, Institut Teknologi Tekstil, Bandung.
- [14] Kusnoko Adimihardjo dan Hary Hikmat, 2004, Participatory Research Appraisal, Penerbit Humaniora, Bandung.
- [15] Mondy & Noe, 1996, Human Resources Management, New York: Prentice Hall Inc.
- [16] Mudrajat Kuncoro, 2001, Analisis Profil Masalah Industri Kecil dan Rumah Tangga: Study Kasus Kabupaten Ngawi, Jawa Timur, *Jurnal Ekonomi Pembangunan* Vol . 6 No. 1, 2001, Universitas Gadjah Mada, Yogyakarta.
- [17] Muhammad Nasir dan Agus Handoyo, 2003, Pengaruh Orientasi Wirausaha Terhadap Kinerja Perusahaan Kecil Dengan Lingkungan dan Strategi Sebagai Variabel Moderat, (Studi Kasus Pada Industri Aneka di Kota Semarang), *Jurnal Bisnis Strategi* Vo. 12 Desember 2003, Universitas Diponegoro Semarang.
- [18] Minzberg Henry, 1990, The Design School : Reconsidering The Basic Premise Of Strategic Management, *Strategic Manajemen Jurnal*.
- [19] Nian S. Djoemena, 20000, Lurik Garis Garis Bertuah, The Magig tripes, Penerbit Jakarta.

## MANAGING RESEARCH AND DEVELOPMENT ORGANIZATION IN VOCATIONAL HIGHER EDUCATION

Ediana Sutjiredjeki<sup>1</sup>, Katharina Priyatiningih<sup>2</sup>, Nani Yuningsih<sup>3</sup>

<sup>1,2,3</sup> UPPM-Politeknik Negeri Bandung

<sup>1</sup>ediana\_sutjiredjeki@yahoo.com, <sup>2</sup>katrinpry@yahoo.com, <sup>3</sup>nani.yuningsih@gmail.com

### Abstract

One of the most important success factor in the national economic growth is the systematic utilization of science and technology. Hence, productivity and quality of R&D endeavors which are implemented in research organizations become a prime key. This paper describes a strategy to increase research productivity and quality in Politeknik Negeri Bandung (POLBAN). As one of the largest vocational education institution in Indonesia, Politeknik Negeri Bandung (POLBAN) offers 32 course programs which consist of engineering, commerce, tourism, and English language programs. With a number of more than 480 lectures who are supposed doing R&D activities, POLBAN is very prominent to support development of industries, either SME and high tech industries. Unfortunately, at present the number of distinctive research carried out in POLBAN is very small compared to the number of lecturers.

While research activity becomes a compulsory in vocational higher education, POLBAN face critical challenges such as limited research funding support, creating research environment, motivating lecturer, accessing information, and marketing research products. The way to alleviate these problems will make better on productivity and quality of R&D efforts which leads to academic research competitiveness in POLBAN. Properly managing an academic R&D organization effectively turns into very significant as well. Application of quality standards such as ISO 9001 directs an enhancing of research management in fact. Furthermore, collaborating with industries and other research organizations will improve research environment and the ability to catch up the technology changes.

**Keywords:** productivity and quality of R&D effort, managing academic R&D organization, academic research competitiveness, quality standard

---

### 1. Introduction

Polytechnic in Indonesia, Polytechnic in Indonesia, such as Politeknik Negeri Bandung (POLBAN) plays a very important function in preparing the Indonesian workforce for employment. Like other higher education institutions POLBAN performs *Tri Darma Perguruan Tinggi*, i.e. mission of teaching & learning, research & development, and community services. POLBAN providing high quality education and training to industry standards is the core function. As one of the largest vocational higher education in Indonesia, POLBAN offers 32 study programs. Based on the given mandate for vocational education, employability of POLBAN graduates is the number one priority to fulfil middle level manager and the outcomes have been consistently high.

To conduct the mission, POLBAN is supported by more than 480 lectures who are supposed doing R&D activities. POLBAN would be a very prominent partner for industries to develop their competitiveness, especially in this knowledge based economic era. The role of higher

education as a major driver of economic development as well as technological advancement is well accepted. This role will increase as further changes in technology, globalization, and demography impacts on the world. In responding to that initiative, POLBAN has the capacity and knowledge to play this important role.

POLBAN's dream is to be a leading National Applied Science Research Centre which conduct various research and development in areas of Engineering, Business and Commerce, and Tourism. POLBAN vision is to strengthening the applied research capacity that leads to better service for high tech industries and/or small-medium-enterprise (SME) requirements in research, and development and commercialization in order to prosper the nation [1]. This paper describes POLBAN research strategies in order to achieve the vision, and it is organized as followed. The existing research organization, the current research activities, and challenges are discussed in section two. Section three explains the POLBAN research strategies, includes the POLBAN strategic research planning, research quality standards, and planning of research organization restructuring. Finally, a

closing remark is presented in section four. This section highlights the critical points which have to be alleviated in the near future.

## 2. Research in POLBAN

One of the most important success factors in the national economic growth is the systematic utilization of science and technology. Therefore, productivity and quality of research and development (R&D) endeavors which are implemented in research organizations become a prime key. Currently R&D activities in POLBAN are managed by Research and Community Service Unit or UPPM (*Unit Penelitian dan Pengabdian kepada Masyarakat*). The UPPM is a technical implementation unit within POLBAN, that serves as the managerial executive which facilitates, coordinates, and supports the implementation of research activities, community services and cooperation between institutions conducted by the academic community of POLBAN. This unit is responsible directly to the Director of POLBAN. Figure 1 depicts the structure of the research organization or UPPM.



Figure 1. Research organization in POLBAN

Compared to academic research organization within a university, this unit is small. In addition, a research in universities is usually conducted by students, specially postgraduates and Ph.D students, or research associates under the direction of university professor. This situation will not be happened in vocational higher education, viz. POLBAN, since at present vocational higher education institutions in Indonesia can only run Bachelor degree called *Sarjana Terapan*.

Research activities in POLBAN mainly is focused on the applied research and development which are based on basic science research. At the moment, the number of lecturers who conduct a research is less significant. Compared to the total number of lecturers in POLBAN, only 18% of them are doing research, as shown in Figure 2.

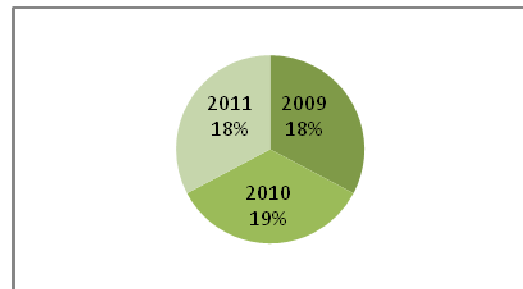

Figure 2. Percentage of POLBAN lecturers conduct research

Currently, the research composition consists of Engineering 61%, Commerce 25 %, Basic and General knowledge 10%, and English 4%. The type of research varies, for instance research for the novice, applied research, product development and innovation research. Subjects of research covers from telemedicine, robotic, finance, government policy, tourism, supply chains, material sciences, green environment, building construction and renewable energy.

Around 65% of POLBAN research grants come from government funding, viz. DIKTI and KNRT. While POLBAN expenditure for R&D activities is Rp. 730,000,000 per years. The total R&D investment for the year 2011 is Rp. 2,186,346,000. In addition, this year POLBAN has awarded a national strategic competitive research grant from DIKTI. The competition of this research grant is very tight, only few higher education institution are eligible to conduct this research, and POLBAN is the only vocational higher education granted.

Although the amount of the research funding during the last three years tends to increase, POLBAN is still struggling to improve the research quality and also the research number. POLBAN faces critical challenges such as creating research environment, motivating lecturer, marketing research products, and increasing external research funding to support research activities of all academic staff and students. Moreover, opportunities of the change in Indonesia government policy of research management has to be anticipated as well.

## 3. Research Strategies of POLBAN

Based on the Government regulation No. 17, 2010, Polytechnics has to conduct research activities which mainly focused on applied research. Successful applied research results in technology development and implementation [2]. We realize that technological innovation is almost definitely the key driver of long-term economic growth of a nation.

To develop a feasible research strategy for POLBAN, the research strategy team has been set up. The task of the team is to analyze POLBAN's

competitive position against a ring of peer communities, assess the POLBAN's existing and emerging research strengths, evaluate research group within POLBAN, and identify the best research facility which practices on a national basis. According to the results come a series of findings and recommendations which will be integrated into the POLBAN strategic research planning.

With the purpose of increasing POLBAN academic research competitiveness A number of strategies has been defined by the team, for examples:

1. Develop a research strategic planning based on the self evaluation;
2. Apply research quality standard, includes; quality standards for the R&D organization
3. Strengthen research groups, in particular a research group of the competitive research subject;
4. Define POLBAN strategic competitive research based on the themes which meet to the National research agenda, and industry requirements;
5. Set up technology transfer and community services;
6. Set up business and innovation centre;
7. Increase IPR ;
8. Increase external research grants.

The research strategic planning is an essential first step in the development of a results-based accountability system [3]. Therefore by doing this, the quality of the research activities might be improved.

The strategic research planning is identified as the process of addressing the following questions:

- Who are we?
- Where are we?
- Where do we want to be?
- What do we have to work with?
- How do we get there?
- How will we know how we are doing?

To guarantee the research quality, a Research Quality Assurance Group will be set up. The group performs the task of assuring that products or outputs of conducted research meet specified requirements. Some decisive factors to evaluate a research topic and or a research output are specified as followed :

- State of the art technology
- Availability of the technology roadmap
- Possibility to get the IPR
- Strategic values of the research
- Business opportunity of the products
- Acquisition of the core technology
- Product innovation.

Additionally, a specific quality procedures to guide the lecturers has been designed according to

international quality standard. In this case, the ISO 9001 is applied in POLBAN since 2008. This ISO quality procedures provide an operational framework not only for R&D organization in POLBAN, but also for the whole POLBAN management system.

The R&D organization success is measured according to specific quality standard. There are a number of ways of looking R&D organization effectiveness and productivity [4].

Output of R&D organization can be measured by three groups, namely process measures, result measures, and strategic indicators. POLBAN translates parameters in each group become steps of quality standards which relate to activities, organization objectives, and long term strategic aspect of R&D organization. Some examples of quality standard are [4]:

- Number of responses sent to enquiries from outside institution
- Number of technical reports published
- Number of patents generated
- External research grant obtained
- Number of innovation developed and adapted for commercialization
- Stability of research funding
- The degree of customer satisfaction with research output.

Regarding to those quality standard, there are requirements to expand the structure of research organization in POLBAN. A number of new subdivision should be added to the existing structure of UPPM, as shown in Figure 3.

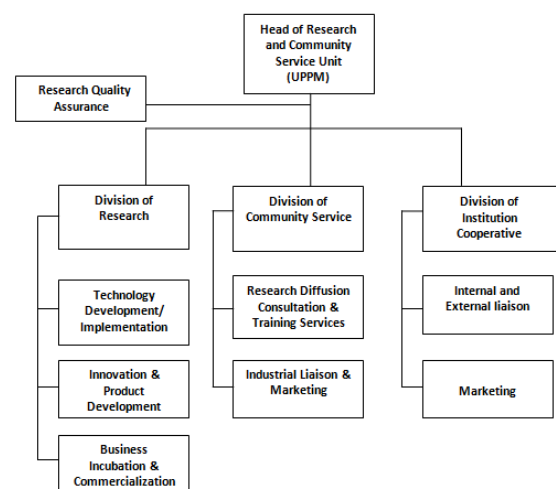

Figure 3. Proposed R&D organization

Looking forward to the change in technology, the proposed R&D organization is provided with Technology Development/Implementation subdivision, Innovation and Product Development subdivision, Business Incubation & Commercialization etc. With applying the new R&D organization, it is



expected that the research environment might be improved, the research productivity can be accelerated, and the research quality can be maintained. Moreover the most important is POLBAN may contribute to the national economic development.

Strengthened linkages with Industry is obligatory for vocational education. This requirement is assured by the Industrial Liaison and Marketing sub-division. Vocational higher education institutions such as POLBAN is the incubator for new ideas, concepts and inventions as the research outputs, while industries provide the means for turning them into need-satisfying products. Partnerships between industries and POLBAN will offer the platform for accelerated national development through the research activities undertaken in the vocational education.

The new POLBAN R&D organization is being proposed in the Senate Academic. It is still long way to go, before the new R&D organization can be approved. Moreover, in conjunction with the change of R&D organization in POLBAN, the authorization of the existing research unit should be upgraded to comply with the additional assignments.

#### 4. Closing Remarks

Managing academic R&D organization, especially in vocational education is much different with managing other R&D organizations in general. The thing which makes different is the fact that research activity in higher education is only one third of lecturer occupations. In addition to research activities, a lecturer still has other obligations for teaching and doing community services.

Research and development in vocational higher education is not a competitor for academic research in universities. Research in university can be focused on high-tech fields or basic and applied research areas. While research in vocational education or polytechnic should be directed into equivalent advantages, popular subjects, and feature majors. A cooperation with corresponding

industries around the environment must be encouraged.

Relating to economic development, in the near future the role of R&D activities in vocational higher education will be more essential. As a result, a better management of the R&D organization becomes imperative. In order to improve the quality of research and to increase the skills, and the research ability of lecturers in vocational higher education, the research activities have to be focused. As an example research in POLBAN might be concentrated to development of small- and medium-sized enterprises, and pay attention on solving crucial theoretical and practical problems related to local economy and industrial development.

Currently, most of lecturers in POLBAN spend their time only for teaching, so they do not have enough time for conducting a research. This situation should be shifted gradually. Hence, the time table should be re-managed to facilitate them for conducting a research.

In order to improve the quality of research and to increase the research ability of lecturers in vocational higher education, such as POLBAN, one of the best solutions is by integrating production, teaching and research activities to optimize their capabilities, as we can learn from China [5].

#### REFERENCES

- [1] Senate of Politeknik Negeri Bandung, *Rencana Strategis Politeknik Negeri Bandung 2011 – 2015*.
- [2] T. M. Khalil, *Management of Technology – The key to competitiveness and wealth creation*, International edition, McGraw-Hill Singapore, 2000.
- [3] Th. Bemelmans, "Strategic Planning for Research and Development", *Long Range Planning*, vol. 2, 1979, pp. 33-44.
- [4] R.K. Jain and H.C. Triandis, *Management of R&D Organizations – Managing the Unmanageable*, John Wiley & Sons, New York, 1990.
- [5] Z. Zhang, "Orientation and strategy of applied university in cooperative education", <http://www.seiofbluemountain.com/search/detail.php?id=1513>

# ALTERNATIVES FINANCING MODEL FOR VOCATIONAL HIGH SCHOOLS FIELD OF CIVIL ENGINEERING STUDY PROGRAM

**MachmudSugandi**  
gandhyy\_06@yahoo.com.au

## Abstract

It is assumed that vocational high schools need high financing. This is due to expensive learning processes, particularly the practical learning processes, which need much funding for workshop equipment, workshop materials, power and fuel supply, and for hiring technicians. Because of this high educational cost, vocational high schools need to find alternative of financing model to obtaining sustainable teaching-learning processes so as to preserve the educational quality.

The result of case study conducted at the State Vocational High School in East-Java, reveals that school financing is obtained from the following sources: 83.33% from the Central Government, 3.43% from the Province Government, 5.53% from District Government, and 2.32% from Local Community. The description of these sources indicates that the biggest percentage (77.78%) is obtained from the Central Government. It is well-known among education experts and practitioners that particularly Central Government Funding is susceptible to changes in macro-economics and economics global changing, which eventually may affect the stability of school financing.

The uncertainty of these conditions, the schools need to find specific strategies to maintain funding sources which are not susceptible to changes caused by external factors by means of (1) doing production-based learning, (2) doing teaching-factory, and (3) providing alternate capitals "modal bergulir" and technical assistance for graduates with entrepreneurship potential. This income-generating activity is expected to provide substantial and sustainable funding that will make the schools financially independent and able to produce skilled and productive labor. The students who are involved in the production-based learning have the competency and experience in creating market-oriented product.

**Keywords:** vocational high schools, alternative financing model, income-generating activity.

---

## 1. Introduction

It is assumed that vocational high schools need high financing than other high schools (Klein, 2001). This statement is according to the theoretic and empiric study which is found in the field. It is because practice learning needs more funding than theoretic-learning. This high financing needs due to skills-competencies process which is done in practice-learning, meanwhile in cognitive-competencies it is more theoretic. Practice-learning needs much funding to buy workshop equipment, workshop materials, maintain the equipment, for hiring the technicians and, power and fuel supply.

Financial support for the vocational high school learning process in Indonesia, classified into: (1) local and state government, (2) local community, (3) block grant. The amount of this funding is different between one another depends on the variable of the student, variation of the department, the number of school's collaboration with industry, and in achieving block grant from government and another sources (ADB or World Bank). This financial support is regulated according to the laws of National Education System No. 20 year 2003. Concerning this matter, there should be aforethought in using and operating the funding, so

that this funding could be used effectively and efficiently.

The variable-fund such as from local community, collaboration with industry, production income, and block grant are easily influenced by external factor. Meanwhile, fix-fund from local and state government is limited. However, the vocational high school has to graduate the good alumnus which is ready to work. Regarding this constraint, there should be another source of funding which is managed by the school itself as a generating income so that they could handle their learning processes which are not susceptible to changes caused by external factors.

The alternatives solution to making out these matters could be done in the learning process or when the student graduated. The first alternative is applying production-based learning or production-based training through competence-learning for the student in the last grade in doing productive workshop in their own group. It means that the students likely face the real condition in industry and have to produce a certain elements of that industry which suitable with the department of the school. The quality of the product under the control of the industry itself, so the students must come up

expectation of the industry since picks the raw material, production process, and quality control. In this learning process, the industry is as a supervisor so it could decrease the fail product. The approach which usually used in modification learning-based production is work-based learning or project-based learning.

Second alternative is providing alternate capital for the potential graduate students and technical assistance for them with entrepreneurship potential. This is based on the report of their competence exam and their parents' business background. Therefore, the student could establish their own business according to their competency, as well as build up their parents' business. This alternates capital come from the local government or banking with a low interest. Then, there is a technical assistance between school and lender to supervise the funding, technical guidance and entrepreneurship, and monitoring and evaluating implementation of the program.

### **1.1 Funding in the Vocational High Schools**

The source of the funding in education-process and the amount of funding allocation is ruled according to Amendment Constitution of 1945 Republic Indonesia number fourth, National Education System of Law No. 20 year 2003, and government regulation No. 19 year 2005 about Standard National of Education. It is stated that the nation provide at least 20% of their national and local income to commit education national learning process. The funding for the education needs become the responsibility between state and local government, and community. Moreover, the sources of the funding have to determine according to justice, sufficiency, and continuity.

According to Gasskov (2002: 204), generally the education funding mechanisms of vocational high school have to portray their principle that education or training is a service and the student or the training must carry on the fund. Finally, the aim of this skill-learning process could make a benefit for the person as well as the society. This personal and social benefit lead us for the concept of funding basis which could be as the answer of some questions such as "Who have the responsibility in financing vocational education or vocational training?" According to the social impact, there is stated that the government has the responsibility in financing the educational or training process. Meanwhile, according to personal benefit, there is a concept that there should be a private financing.

### **1.2 Government Financing**

Refer to nation financing, the government big priorities to create social benefit are social development, manpower factor, and income or increase the nation income for the social benefit. According to Gasskov (2000: 193), the government

position in giving equal access for the vocational education is unique, equality in education process and training can be reached through these following financing mechanism: 1) giving learning or training and giving free job offer or with a low fee for everybody who wants to get a skill in public school around the country, 2) training voucher in the form of education service and training for the young people for the short future, and 3) giving the scholarship for them who have low income and have not access to follow the program.

The government funding for the vocational high school in Indonesia could be categorized into: (1) operational subsidy for vocational education process which given regularly and equal to every school according to the variable of the student in every grade, and (2) grant funding to the school according to their program in a competitive way. However, government financing support is relative smaller to fulfill the educational-learning process needs. Therefore, there should be another financing alternative which more excessively and continue.

### **1.3 Private Financing**

Concept of private finance by the student and the employer is a kind of direct contribution of the learning process or training process, the contribution of employer as the impact of profit from this learning or training program. According to Gasskov (2000: 197), individuals finance training through; (1) fees paid for courses, (2) accepting reduced wages during training periods at enterprises, (3) training after working hours, and (4) repayment of training loans. Private financing is very susceptible because it is depends on parents' financial ability, meanwhile most of the students of vocational high school come from under middle-class which see that education is not their priority in life. This fact is reinforced with UNESCO's data, that %GDP of Indonesia's education (0.9%) is the lowest in Southeast Asia.

### **1.4 The Existing Financing Pattern**

The overall pattern of funding that is formulated from the research findings on the State Vocational High School field of Civil Engineering study program as follows: the largest source of funding is dominated by source of funds from the Central Government is 83.33%, the source of funds from the Provincial Government is 3.43%, the source of funds for District Government is 5.53%, and the source of funds from Local Community's 2.32%. In detail, the funding can be described as follows: (1) source of funds from the central government used to meet the cost of building infrastructure investment is 93.65%, to personnel expenditure is 16.40%, to non-personnel expenditure is 0.27%. (2) sources of funds from the provincial government used for building infrastructure investment spending is 3.30%, to meet

procurement of instructional material is 11.47%, to operational cost of personnel is 0.50%, to operational of non-personnel is 4.19%, and to meet maintenance infrastructure learning is 0.52%. (3) sources of funds from the District government more widely used for operational costs teaching-learning process consisting operational personnel cost is 71.73% and non-personnel operating costs is 38.78%, and 36,27% used to maintenance infrastructures learning. (4) sources of community funds used to cover the shortage of school operating expenses directly or indirectly covering the sharing fund of procurement of learning facilities is 13.46%, to covering personnel operating costs is 11.37%, and to covering non-personnel operating costs is 56,76%, and maintenance costs of infrastructure learning facilities is about 64.21%

### 1.5 Learning-Based Production

Learning process in vocational high school, in theoretic way as well as practical based on Three

Level Classification System. According to Bott (1996: 20), this system is usually used to determine the grade of study in every task given or to determine whether they are master or not with the study. Three levels Classification System which is showed in the Figure1, will help to determine the way of vocational high school student learning in theoretically and practically.

The School learning in vocational high school has own characteristic than high school. In this school, the practice learning gets the most portions than theoretic learning. According to Three Level Classification System, practical learning include psychomotor domain. The students' competency since the general level to qualified level are the student skill-competency in observing productive material, solving the practice problem, and easily adapting the field work or in reaching specification

Figure 1. Table 1 A Three Level Classification System (Bott: 1996).

		Affective Domain	Psychomotor Domain
General	Knowledge Comprehension	Receiving	Observation Initiation
Working (With Supervision)	Application Analysis	Responding Valuing	Practicing
Qualified (Without Supervision)	Synthesis Evaluation	Organizing Characteristics of the Value Complex	Adaptation

The School learning in vocational high school has own characteristic than high school. In this school, the practice learning gets the most portions than theoretic learning. According to Three Level Classification System, practical learning include psychomotor domain. The students' competency since the general level to qualified level are the student skill-competency in observing productive material, solving the practice problem, and easily adapting the field work or in reaching specification of the product. The learning actualization of the student in reaching psychomotor domain is using production-based learning approach.

Production-based learning or usually called production-based training is a kind of education or training in school through some production of good or service or make a material component of a certain industry according to specification of the product in the market. According to Sasmita (2007:207-212), the purpose of this production-based learning: (1) create a skilled labor which are needed in industry as well as could produce a saleable product, and (2) engraft productive

experience in developing entrepreneurship motivation in creating a commercial service or product. In line with this, Directorate Education Vocational High School (1999), states that production-based learning is a learning-skill process which is created and done according to procedure and work standard in a real job, in order to create product or service according to market demand.

There is another approach which has the same final purpose with production-based learning, one of them is project-based learning and work-based learning. Project-based learning is helping the student in understanding; (1) knowledge and skill and meaningful-use through authentic tasks and work (CORD, 2001; Hung & Wong, 2000; Myers & Botti, 2000; Marzano, 1992), (2) expanding the knowledge through extra activities with the support of designing learning process or open-ended investigation, in which the result or the answer is not fixed by certain perspective, and (3) in a developing learning process through a real work and cognitive negotiation inter-individual in a collaborative work field.

Work-based learning/WBL according to Bound (2003) is a learning program which create to portray the collaboration between vocational high school and work field or industry, as the result this program could fulfill the student's need in learning process, and give the contribution to the developing the company as well as industry. WBL is a formal program in vocational high school. The first aim of this program is making closer the relation between school and the real work field.

### **1.6 Theoretic Support on Production-based Learning**

Theoretic learning support on productive workshop in vocational high school on the product oriented which fulfills the consumer's need is a learning theory; (a) constructivism, and (b) experiential.

According to Mayer (1992), in the learning practice, especially in the last half century, there is a displacement learning theories, from the behavioristic theory to the cognitive, from the cognitive to the constructive. The implication of this changing is seen from the perspective that curriculum as a body of knowledge or skill-transfer is something naïf. If the constructive point of view about individual as a constructor is acceptable, it is better to see the curriculum as a strategy of study and a number of tasks. Therefore, there is a changing perspective in the class room. The teacher is not only as a source of knowledge and the student as the recipient, but they are act as a partner, the teacher as a critical constructive guidance and instructor. The class room sphere is created according to the social setting which gives countenance to the knowledge and skill construction (Driver & Leach, 1993).

Production-based learning is based on the constructivist theory. There is a prominent learning strategy in constructivist learning, such as (a) collaborative learning strategy, (b) the student is active, (c) laboratory activity, (d) field experience, (e) and solving problem. The main teacher's duty in this learning process is to control the student's idea and interpretation in understanding specification of a product as industry and consumer's necessity, and in giving alternative through the implication, data, and argument.

There are a lot of study declare that constructivism is a theory based on the student experience in construct their knowledge (Murphy, 1997; Brook & Brook, 1993, 1999; Driver & Leach, 1993; Fraser, 1995). The constructivist learning is focus on the active learning in order to get the self-experience, than passive learning. From this perspective, studying is not only stimulus-responed as stated by behaviorists, but a process of self-regulation and developing conceptual structure through a process of reflection and abstraction (Von Glaserfeld in Murphy, 1997). The real activity in

doing production-based learning is giving experience which could help the student correlate their conceptual knowledge with the real market so that they could improve their skill (Barron, Schwartz, Vye, Moore, Petrosino, Zech, Bransford, & The Cognition and Technology Grou at Vanderbilt, 1998). This is showing that production-based learning is a portrayal of the real work life, has a potency to expand and dig out the procedural and conceptual knowledge (Gagne, 1985), which in another terms is called knowing that and knowing how (Wilson, 1995). Knowing 'that' and 'how' is not sufficient without the disposition to 'do' (Kerka, 1997). The expanding and digging out in understanding the knowledge could be used as an academic cleverness.

Collaborative learning strategy is an important project-based learning in this constructive learning theory. Learning together with other learners can be a very powerful form of learning, in which learners help each other's in this construction processes (Simons, 1996:294). According Vygotsky (1978) the collaborative learning strategy is based on the Zone of Proximal Development theory (ZPD). According to Davydov (1995), Vygotsky recommends three level or zone concept, in which could make the student more success with a guidance of experience-partner. ZPD is defined as "the distance between the actual development level as determined by independent problem-solving and the level of potential development as determined through problem-solving under adult guidance or in collaboration with more capable peers" (Gipps, 1994: 24-25). This partner is not dictating the student, but involve in the collaboration, demonstrative, and modeling process.

This contextualization principle which is the important characteristic in project-based learning is come from the theory of constructive study. The constructive experts state that studying is a process of making up the reality through learning process. Studying is closely related to what the student's learnt and knew (Bednar, Cunningham, Duffy, & Perry, in Dunn, 1994). The constructivist experts deny the concept of real life existence; they state that the real life is just idiosyncratic which we build up. There are no two people who have the same concept; it is based on the view of point that the combination of their own experience and knowledge will create different interpretation. Based on this perspective, there is suggestion that the learning process should be taken on the broader sense that could reflect the real life and this have a close relation with the aim of this study that is implementation of the study. In short, authenticity is important. As has been stated, project-based learning is an authentic learning model.

Jonassen (1991), and Brown Collins and Duguid (1988) also have the same thought that context is an important part of the knowledge

learning process in relation with that learning process. The implication on the learning process is creating the actual studying condition, authentic, and relevant with the certain learning context. The teacher and the learning model which is created focus on the realistic approach in which the students are easily solving the problem in the real life (Jonassen, 1991). The constructivist learning condition is a place where learners may work together and support each other as they use a variety of tools and information resource in their pursuit of learning goals and problem-solving activities (Wilson, 1995:27). Project-based learning is also an approach which creates a realistic learning condition, and focus on the problem solving which may be happen in the real life.

Production-based learning is also supported by experiential learning theory. As stated by William James that the best learning process is through their own experience, sensory experience is a basic learning, and the effective learning is holistic, and interdisciplinary (in Moore, 1999). These principles are also applied on the production-based learning. The students learn by themselves how to identify the materials until control the product quality. The teachers are as a guidance, facilitator, and partner. The product which is chosen is interdisciplinary because it contains of many kinds of discipline which is needed in finishing the problem in the production process. The student learning process is a sensory experience as a studying foundation. As well as by John Dewey that experience is a key element in the learning process (Moore, 1999; Knoll, 2002). Dewey sees that studying is "process of making determinate the indeterminate experience." It means that all of these experiences is connected each other between the learning situation and with the problem appeared. According to the past knowledge, the new knowledge builds up a new knowledge (billet, 1996). Production-based learning could be seen as a stabilization learning process, expanding the knowledge, and correcting the knowledge. This statement also stated by Marzano (1992) that studying through the real condition (such as: investigation and problem solving) could be expanding and correcting the knowledge.

### 1.7 Providing Alternate Capital

The reason of searching the alternate capital is a limited financing donation from the state or local government, and susceptible donation from the students, local community, and the industry or production unit. The vocational high school together with the sponsor make collaboration in creating a new innovation that is providing alternate capitals for the potential graduate student. Therefore, the student could establish their own business according to their competency, as well as build up their parents' business.

Providing alternate capital has been done in some vocational high school in East Java, Southeast Sulawesi, and South Sulawesi. The student or the graduate student who are involved in the production-based learning have the competency and experience in creating market-oriented product. The procedure of alternate capitals lending are: (1) competition level, in this process the school offers the proposal to the sponsor, (2) implementation program, the student or the graduate student get the alternate capitals. The amount of the alternate capital is based on the proposal, and (3) monitoring and evaluation level, in this level the sponsor have to monitor and evaluate the implementation of the funding.

The contribution from this alternate capital to the school as the income generating is 8%/year in flat calculation, so that every student has to turn it back on time.

## 2. Conclusion

The high financing need of vocational high school, demand of the good quality of the graduate student from vocational high school, and a limited funding have a big effect on the learning process especially in this crisis. Therefore, the schools alternative funding is developed in order to create a good quality vocational high school, while the alternate funding could be done in the form of: (1) doing production-based learning, and (2) doing teaching-factory, and (3) providing alternate capitals "modal bergulir" and technical assistance for graduates with entrepreneurship potential. This income-generating activity is expected to provide substantial and sustainable funding that will make the schools financially independent and able to produce skilled and productive labor. The business could be a new business, or continuing the parent's business or collaboration with the industry around the vocational high school. The students who are involved in the production-based learning have the competency and experience in creating market-oriented product.

## ACKNOWLEDGMENT

The completion of my research at Postgraduate of Yogyakarta State University is made possible by the generous help of many institutions and individuals. Therefore, I am very grateful to the Directorate General of Higher Education (DGHE) at the Ministry of Culture and Education for giving financial support of doctoral dissertation grants program.

Word of thank from researcher submitted to the head master of state vocational high schools in the province of East Java, who was selected as survey respondents and who have given permission to perform data retrieval funding of education at the schools.

## REFERENCES

- [1] Ajeyalami, D.A. (1993). *Teacher Strategies Used by Exemplary STS Teachers. What Research Says to the Science Teaching, VII.* Washington D.C: National Science Teachers Association.
- [2] Barron, B.J., Schwartz, D.L., Vey, N.J., Moore, A., Petrosino, A., Zech, L., Bransford, J. D., & The Cognition and Technology Group at Vanderbilt. (1998). *Doing with Understanding: Lessons from Research on Problem- and Project-Based Learning.* *The Journal of the Learning Science*, 7, 271—311.
- [3] Bott, Paul A. (1996). *Testing and Assessment in Occupational and Technical Education.* Boston: Allyn and Bacon.
- [4] Bound, D., and Solomon, N. (2001). *Work Based Learning, A New Higher Education?* Buckingham: St Edmundsbury Press Ltd.
- [5] Brook, J.G., & Brook, M.G. (1993). *The Case for Constructivist Classrooms.* Virginia: ASCD.
- [6] Brook, J.G., & Brook, M.G. (1999). *The Constructivist Classroom. The Courage to Be Constructivist.* Readyroom, 57(3) November 1999. <http://www.ascd.org/readyroom/edlead/9911/brooks.html>
- [7] Brown, J.S, Collin, A., & Duguid, P. (1988). *Situated Cognition and the Culture of Learning.* *Educational Researcher*, 18(1), 32—42.
- [8] CORD. (2001). *Contextual Learning Resource.* <http://www.cord.org/lev2.cfm/65>.
- [9] Davydov, V.V. (1995). *The Influence of L.S. Vygotsky on Education Theory, Research, and Practice.* *Educational Researcher*, 24(3), 12—21.
- [10] Driver, R., & Leach, J. (1993). *A Constructivist View of Learning: Children's Conceptions and the Nature of Science. What Research Says to the Science Teaching, VII.* Washington, D.C.: National Science Teachers Association, 103-112.
- [11] Gagne, E.D. (1985). *The Cognitive Psychology of School Learning.* Boston: Little, Brown, and Company.
- [12] Gasskov, Vladimir. (2000). *Managing Vocational Training Systems. A handbook for senior administrators.* Geneva: International Labour Organization.
- [13] Gipps, C. (1994). *What We Know about Effective Primary Teaching. Dalam Jill Bourne (Ed.), Thinking Through Primary Practice.* London: The Open University.
- [14] Hung, D.W., & Chen, D.T. (2000). *Appropriating and Negotiating Knowledge.* *Educational Technology*, 40(3), 29—32.
- [15] Hung, D.W., & Wong, A.F.L. (2000). *Activity Theory as a Framework for Project Work in Learning Environments.* *Educational Technology*, 40(2), 33—37.
- [16] Jonassen, D.H. (1991). *Objectivism versus Constructivism: Do We Need a New Philosophical Paradigm?* *Educational Technology Research and Development*, 39(3), 5—14.
- [17] Kerka, Sandra. (1997). *Constructivism, Workplace Learning, and Vocational Education.* ERIC Digest No. 181. Columbus OH: ERIC Clearinghouse on Adult Career and Vocational Education. Retrieved on December 30, 2006. from <http://www.ericdigests.org/1998-1/learning.htm>
- [18] Klein, Steven. (2001). *Financing Vocational Education: A State Policymaker's Guide. Sorting Out The Byzantine World Of State Funding Formulas, District Cost Variation, And Option For Supporting The Provision Of Equitable, Quality Vocational Education In High Schools.* (Instructional Resource No. 30). Athens, GA and College Park, MD: Educational Resources Information Center (ERIC Document Reproduction Service No. ED457329).
- [19] Knoll, M. (2002). *The Project Method: Its Vocational Education Origin and International Development.* *Journal of Industrial Teacher Education*, 34(3).
- [20] Marzano, R.J. (1992). *A Different Kind of Classroom: Teaching with Dimensions of Learning.* Virginia: ASCD.
- [21] Mayer, R.E. (1992). *Cognition and Instruction: Their Historic Meeting Within Educational Psychology.* *Journal of Educational Psychology*, 84(4), 405-412.
- [22] Moore, D. (1999, January 23). *Toward a Theory of Work-Based Learning.* IEE Brief.
- [23] Myers, R.J., & Botti, J.A. (2000). *Exploring the Environment: Problem-Based Learning in Action.* <http://www.cet.edu/research/conference.html>.
- [24] Sasmita, A.H., (2007). *Implementing Production-Based Training in Practice at Public Vocational High School 6 of Bandung.* *Journal Vocational Technology of Education, INVOTEC*, 4 (11): 207—212.
- [25] Vygotsky, L.S. (1978). *Mind in Society.* Cambridge, MA: Harvard University Press.
- [26] Wilson, B.G. (1995). *Metaphors for Instruction: Why We Talk About Learning Environments.* *Educational Technology*, September-Oktober, 25—30.

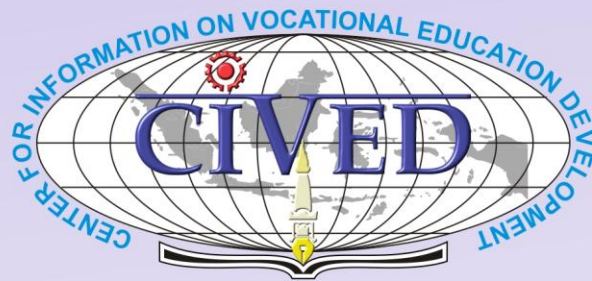

No. ISBN : 979 820 450-6