

PAPER • OPEN ACCESS

The Effect of Masses in the Determination of Optimal Suspension Damping Coefficient

To cite this article: A Yudianto *et al* 2019 *J. Phys.: Conf. Ser.* **1273** 012067

View the [article online](#) for updates and enhancements.



IOP | ebooks™

Bringing you innovative digital publishing with leading voices to create your essential collection of books in STEM research.

Start exploring the collection - download the first chapter of every title for free.

The Effect of Masses in the Determination of Optimal Suspension Damping Coefficient

A Yudianto¹, N Kurniadi², I Wayan Adiyasa³, Z Arifin⁴

¹Politecnico di Torino, Corso Duca degli Abruzzi, 24, 10129 Turin, Italy

²Diponegoro University, Prof.H.Soedarto Street, Semarang, 1269, Indonesia

³Gadjah Mada University, Bulaksumur, Yogyakarta, 55281, Indonesia

⁴Yogyakarta State University, Colombo Street 1, Yogyakarta, 55281, Indonesia

E-mail: s250659@studenti.polito.it

Abstract. The proper design of the suspension damper determines the ride quality and road holding performance of the suspension system against the road excitation. The objective of the present study is to investigate the effect of both sprung and unsprung masses on the root-mean-square vertical acceleration experienced by the occupants to determine the optimal value of the damping coefficient. Road excitation, 2-DOF mathematical model, and ISO 2631 weighting function were numerically modelled into three different cases in Matlab platform. The responses in root-mean-square value of acceleration were then evaluated. Further, the results were compared and the analysis was performed to determine the optimal value of the damping coefficient for the proposed suspension model. The obtained results indicate that varying the sprung masses with the proportional value of unsprung masses does not affect the root-mean-square value, but it increases the value of optimum damping coefficient by 131.5 Ns/m. Making the sprung mass constant increases the root-mean-square value by 0.005 m/s² for each chosen unsprung mass. However, fixing the unsprung mass influences both acceleration and the value of damping coefficient.

1. Introduction

Suspension is essential for achieving adequate road holding behaviour and comfort which determine the distinctive characteristics of each vehicle [7]. By mean of suspension, the wheels are linked to the body or to a frame to allow the distribution of forces complying with the design specification in every load condition. Suspension system must also accomplish their task to absorb and smooth out the shocks received by the wheels from road irregularities which is then transmitted to occupants. However, the sensation of comfort in a vehicle is affected by multiple factors, including the vibration generated by various system in the vehicle. The vibration amplitude corresponds to a given comfort level [8]. Thus, the vibration transmitted to the car body when the car is running needs to be filtered and attenuated by the suspension system to minimize the potentially harmful the effects of the dynamic load on the occupants. The proper value of damping coefficient becomes substantially important in order to have maximum performance on the suspension system and therefore the main function which is, among others, ensuring the comfort feeling perceived by occupants of the suspension system in the vehicle can be fully maximized.

Numerous publications dedicated to the understanding of suspension damping and comfort level have been conducted by several researchers. Sun et al [1] simulated the effect of suspension damping on vehicle ride. The evaluation on vertical acceleration, suspension dynamic deflection and tire dynamic load were evaluated from the model. Moheyeldeen et al [2] analysed the performance indices of air spring suspension over the passive suspension. The obtained values of RMS of body acceleration, suspension travel and dynamic tire force were compared and analysed. Sert et al [3] studied on the optimization of suspension system and sensitivity analysis for improvement of stability in a midsize heavy vehicle. The comparison between the virtual and physical test was performed to understand the



static and dynamic roll behaviour and the improvement to the stability dynamics based on increasing roll stiffness of the suspension. Barethiye et al [4] studied the combination of nonlinear and hysteresis model of shock absorber for quarter car simulation on the basis of experimental data. The results generated by the combined model which were compared to linear as well as piecewise linear model. The proposed model was substantially a better option to study the vehicle characteristic more precisely. In terms of vehicle comfort, Geweda et al [5] developed the vehicle full model with seven degrees of freedom to improve the ride comfort using genetic algorithm optimization and PI controller. The optimized parameters and PI controller give significant improvements of the vehicle ride performance over the passive suspension system. Yang et al [6] studied on ride comfort of tractor with tandem suspension based on multi-body system dynamics. The proposed approach was able to predict and improve the ride comfort by experiment results and could be used for any other specific categories of vehicle. Banerjee et al [7] analyzed the ride comfort of math ride dynamics model of full tracked vehicle with railing arm suspension. This proposed model was considered as generic and computationally efficient for suspension design of tracked vehicles.

It can be inferred from the literature review that a lot of research works were conducted in the topic of suspension system and ride comfort. However, the ride comfort which is linked primarily with the ability of the tires and suspensions to filter out vibration caused by motion on a road that is not perfectly smooth is deeply studied in this work. The aim is to understand the effect of the different values of sprung and unsprung mass applied in the system to determine the value of the most optimum damping coefficient in the suspension system. The external excitation from the road irregularity is the main consideration of the random input of the vibration source. The study was performed by giving different cases to the system to understand the final behaviour of the sprung mass root-mean-square (r.m.s) acceleration. Three different cases were conducted in this study by changing the combination between the sprung mass and unsprung mass. The system was mathematically modelled in Matlab platform so that the dynamic behaviour of the suspension could be simulated.

2. Calculation Approach

A scheme explaining the procedure to measure the r.m.s vertical acceleration in this study is presented in Figure 1. The random input of the road excitation is modelled with taking into consideration the ISO 8606:1995 standard for the value of the roughness and road class. This random excitation becomes the input of the 2-degree-of-freedom quarter-car model which the dynamic behaviour is mathematically modelled in Matlab platform. ISO 2631 weighting function is included in the calculation. Lastly, the root-mean-square (r.m.s) value of the acceleration described as the function of the damping coefficient can be plotted and analysed.

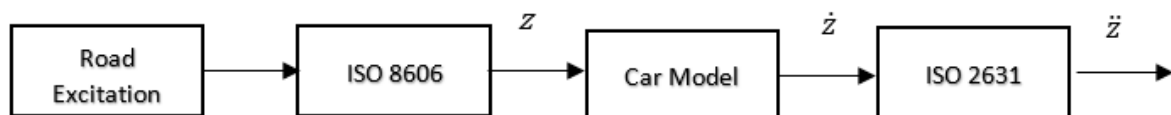

Figure 1. Scheme of the model calculation

2.1. Road Excitation

One of the essential aspects in studying riding comfort is the excitation due to motion on uneven road. Road excitation causes a variable normal load F_z and increases the stressing of the structural elements. As the consequences, it reduces the ability of the tires to exert forces in the x and y direction [7]. In this case, such excitation is nearly impossible to be studied in a deterministic approach and random vibrations becomes the preferable method. The C class road having the value of constant c following ISO 8606 standard with c_{min} 1.28×10^6 m²/cycles/m, $c_{average}$ 2.56×10^6 m²/cycles/m and c_{max} 5.12×10^6 m²/cycles/m is chosen. The road excitation which is expressed in the function of distance following the

law $h(x)$ needs to be transformed into the function of time $h(t)$ with the consideration that the vehicle travels with the velocity V . Therefore, it is possible to compute the frequency ω referred to time and power spectral density S with referred to time. Once the power spectral density $S(\omega)$ (namely of function $h(t)$) of the vehicle is obtained, the response $S_r(\omega)$ of the power spectral density can be expressed as

$$S_r(\omega) = H^2(\omega)S(\omega) . \quad (1)$$

Here, the excitation namely a function $h(t)$ and the frequency response $H(\omega)$ of the vehicle are known. The r.m.s value of the response is the square root of the power spectral density integrated in the relevant frequency range [7]. In this case, the frequency response $H(\omega)$ is the ratio between the amplitude of the acceleration of the sprung mass and the displacement of the contact point. Finally, the r.m.s acceleration value of the response in the frequency range ω_1 and ω_2 can be expressed as

$$a_{rms} = \sqrt{\int_{\omega_1}^{\omega_2} S_r(\omega)d\omega} . \quad (2)$$

2.2. Quarter-car Model Data and Assumptions

For the sake of simplicity in the calculation, a quarter car model with two degrees of freedom including single wheel with related suspension and part of the body whose weight is imposed on it is generated. The tire is considered as massless spring and both the unsprung and sprung masses are considered. The mathematical model is performed under the assumption that the source of excitation is solely due to road profile. Thus, the wheel is assumed perfectly balanced and the engine and also driveline vibration are negligible. The quarter car model with two degrees of freedom is appropriate for studying the behavior of vehicle suspension in a frequency range beyond the natural frequency of the unsprung mass [7]. In order to understand the effect on the vertical acceleration, varied combinations on both sprung and unsprung masses are performed in each case. The natural frequency F_{nat} of the model is chosen at 1.4 Hz and the vehicle speed V is 50 km/h.

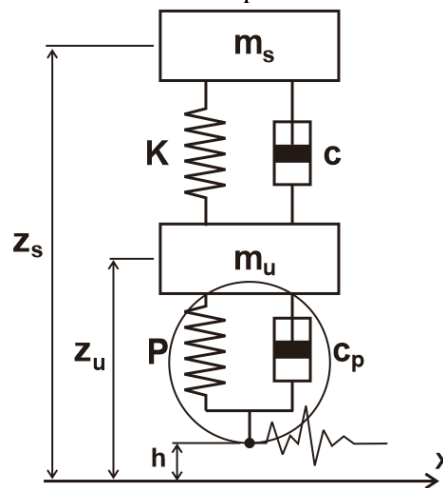

Figure 2. Quarter-car model with two degrees of freedom

The following is the equation of motion of the model.

$$\begin{bmatrix} m_s & 0 \\ 0 & m_u \end{bmatrix} \begin{Bmatrix} \dot{z}_s \\ \dot{z}_u \end{Bmatrix} + \begin{bmatrix} c & -c \\ -c & c + c_p \end{bmatrix} \begin{Bmatrix} z_s \\ z_u \end{Bmatrix} + \begin{bmatrix} K & -K \\ -K & K + P \end{bmatrix} \begin{Bmatrix} z_s \\ z_u \end{Bmatrix} = \begin{Bmatrix} 0 \\ c_p \dot{h} + Ph \end{Bmatrix} \quad (3)$$

Where m_u is the unsprung mass, m_s is the sprung mass, z_u and z_s are the displacement from the static equilibrium position and referred to an inertial frame, K is the suspension stiffness, P is the tire stiffness, c is the damping of suspension, c_p is the damping of the tire which is considered very small and $h(t)$ is the vertical displacement of the supporting point due to road irregularities. In this study, it is defined that damping of the tire c_p is neglected, the value of P is equal to $10K$ and m_s is equal to $10m_u$. The stiffness of the suspension is defined as

$$K = m_s (2\pi F_{nat})^2 \quad (4)$$

An optimum value of damping coefficient can be found by keeping the vertical acceleration in the minimum value in a large range extending up to the natural frequency of the unsprung mass. The mathematical expression of the optimum damping of the proposed model is given by the following.

$$c_{opt} = \sqrt{\frac{Km}{2}} \sqrt{\frac{P+2K}{P}} \quad (5)$$

Thus, recalling also Eqn (1) and Eqn (2) it can be said that the r.m.s value of the vertical acceleration of the sprung mass of the model is

$$a_{rms} = \sqrt{\int_{\omega_1}^{\omega_2} \omega^4 H^2 S d\omega} = \sqrt{cV} \sqrt{\int_{\omega_1}^{\omega_2} \omega^2 H^2 d\omega} \quad (6)$$

Where H is the frequency response yielding the displacement of the sprung mass.

In order to understand the behaviour, numerous iterations were performed up to which value of the optimum damping coefficient could be observed. As explained in the previous, the optimum damping coefficient is obtained for the minimum value of the r.m.s acceleration perceived by occupants.

2.3. Weighting Function

The occupants of a vehicle experience vibrations of different amplitudes and frequency which affect in the reduction of comfort perception [8]. One of the limitations of the exposure to vibrations has been defined in ISO 2631 which is a weighting function addressing human exposure to multiple mechanical shocks. ISO 2631 standard distinguishes the frequency range that may cause a reduction of comfort, fatigue, health problems, and also that may cause motion sickness [7]. It suggests the weighting functions of the frequency to calculate the r.m.s values of the acceleration referring to the acceleration due to vibration. As such, what creates discomfort in particular frequency range is the ratio between acceleration and frequency. In this case, the road excitation is transferred into the suspension system, chassis, vehicle seat and, finally, it will be perceived by the occupant. For the simplicity, the vertical acceleration perceived by occupant is directly measured in the point of sprung mass. The transfer function of the ISO 2631 weighting function is expressed in the following.

$$H_{2631} = \frac{80.03s^2 + 2.989s + 0.02108}{s^3 + 78.92s^2 + 2412s + 5614} \quad (7)$$

3. Results and Discussions

Three different cases were conducted to understand the behaviour of the identified problem. The chosen values of sprung masses are based on the average mass of European passenger's vehicle under the assumption that the mass is equally distributed in all four corners.

3.1. Case A: Sprung and unsprung mass vary

Three sprung masses of 450 kg, 550 kg, and 660 kg are chosen in the first case and the value of unsprung mass is under condition that the value is 10% of each chosen sprung mass. Therefore, the value of suspension stiffness also follows the Eqn (4) and, therefore, each value of the combination unsprung and sprung mass has their own value of suspension stiffness. The damping coefficient of the

tire is negligible since it is considered very small. The tire stiffness is chosen that the value is 10 times greater than the stiffness of suspension spring.

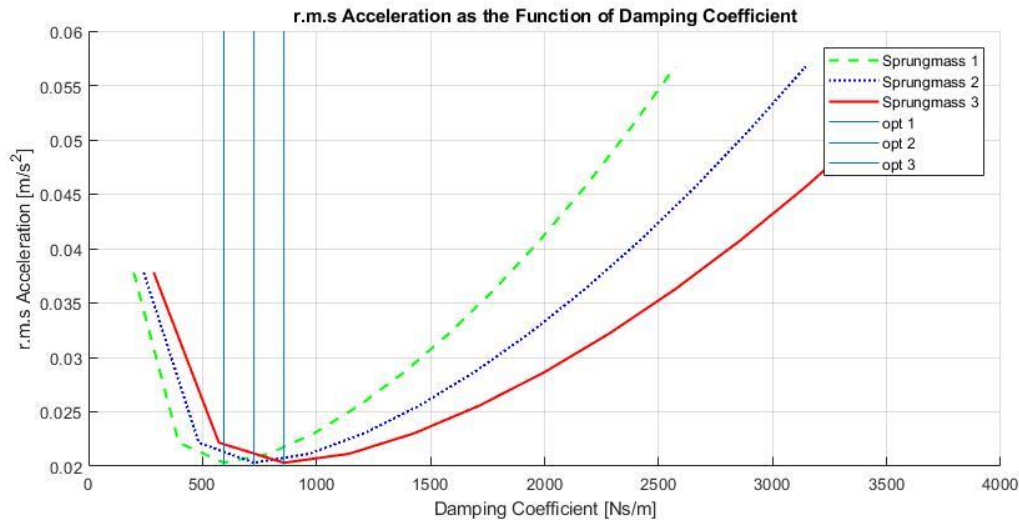

Figure 3. Case A result

Figure 3 compares the results of the case A. Varying the chosen value of sprung mass and keeping the value of unsprung mass at 10% of the sprung mass follows that the most optimum value of damping coefficient is getting greater as the sprung mass value increases. The dashed line represents the iterations of the 450 kg of sprung mass. It follows that the most optimum damping coefficient is achieved at the value 594 Ns/m. The dotted line explains the behaviour of the iterations for the second sprung mass case which is 550 kg. In this case, the lowest vertical acceleration is reached at the point of 725 Ns/m of damping coefficient. The last line depicts the curve of the 660 kg sprung mass. By increasing 100 kg of masses from the second value, the optimum damping is achieved at 857 Ns/m. The lesser calculated values with respect to the optimum damping coefficient give significant increase of the vertical r.m.s acceleration. The same behaviour will also occur if the value of damping is increased, but with the slight lower parabolic increment. However, the three variations of sprung masses do not affect the r.m.s acceleration experienced by occupants and all the three cases have the minimum r.m.s acceleration value at 0.02 m/s^2 .

3.2. Case B: Unsprung mass is fixed

In case B, the value of unsprung mass is kept constant at 55 kg. Three different sprung masses are applied in the study with the equal value as before which are 450 kg, 550 kg and 650 kg. The value of natural frequency is also equal. The stiffness of the suspension following the Eqn (4), so that it has three different values of suspension stiffness in the calculation and the values of tire stiffness is ten times greater than suspension stiffness. Tire damping is neglected as well.

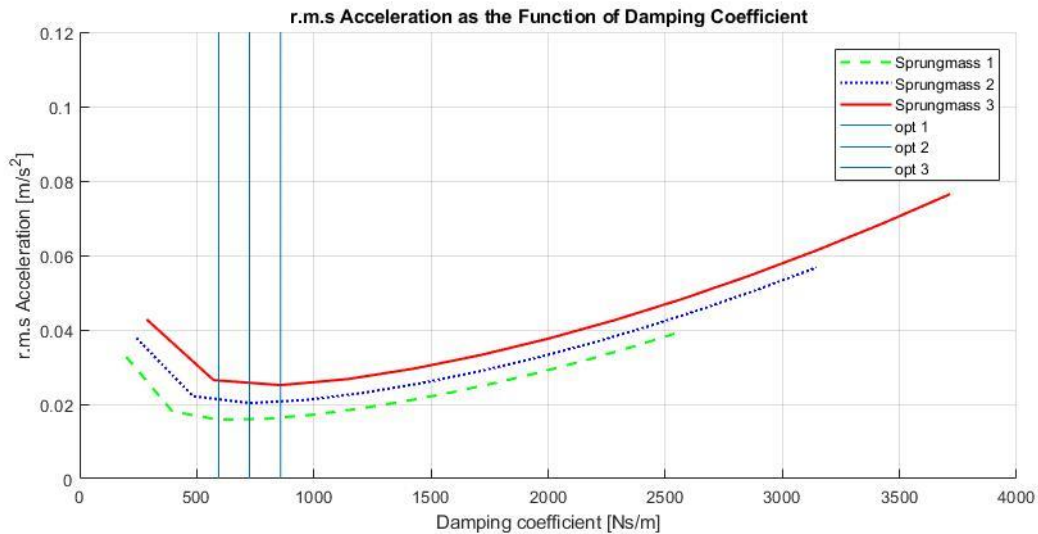

Figure 4. Case B result

Different behaviour of the results is depicted in the Figure 4. By keeping the value of unsprung mass constant, three different optimum damping coefficients with different values of r.m.s acceleration were obtained. The dashed line shows the r.m.s value as the function of the damping coefficient for 450 kg sprung mass which initially, the lowest damping coefficient gives higher value of r.m.s up to then it reaches the minimum value of 594 Ns/m with 0.016 m/s^2 of vertical r.m.s acceleration. The second line, the dotted line, is the representation of r.m.s acceleration as the function of damping coefficient for 550 kg of sprung mass. Very similar curve is plotted. Yet, it gives the higher value of acceleration perceived by occupants, which is approximately in the order of 0.020 m/s^2 at 725 Ns/m of damping. The continuous line represents the third situation which applied 650 kg of sprung mass. By having value of unsprung mass of 55 kg, for 650 kg of sprung mass contributes to the greater vertical acceleration perceived by occupants at about 0.025 m/s^2 for 858 Ns/m suspension damping coefficient. For all three conditions, the increment of damping coefficient gives the increase of vertical acceleration with very similar shapes. It can be said that for constant unsprung mass, the increment of sprung mass contributes to different value of the lowest r.m.s acceleration which determined the comfortability of the occupant to determine the optimum value of the damping coefficient. In case of constant unsprung mass, the heavier sprung mass, the higher value of the optimum damping coefficient followed also by higher r.m.s acceleration.

3.3. Case C: Sprung mass is fixed

Case C fixes the value of sprung mass at 550 kg. The unsprung masses are chosen as 45 kg, 55 kg and 65 kg. The natural frequency of the system is defined as 1.4 Hz. Since the value of sprung mass is fixed, based on the Eqn (4), there is only one value of suspension stiffness applied in the calculation of the three different unsprung masses. As equal to the previous two cases, the tire stiffness is 10 times higher than the spring stiffness and damping due to tire is negligible.

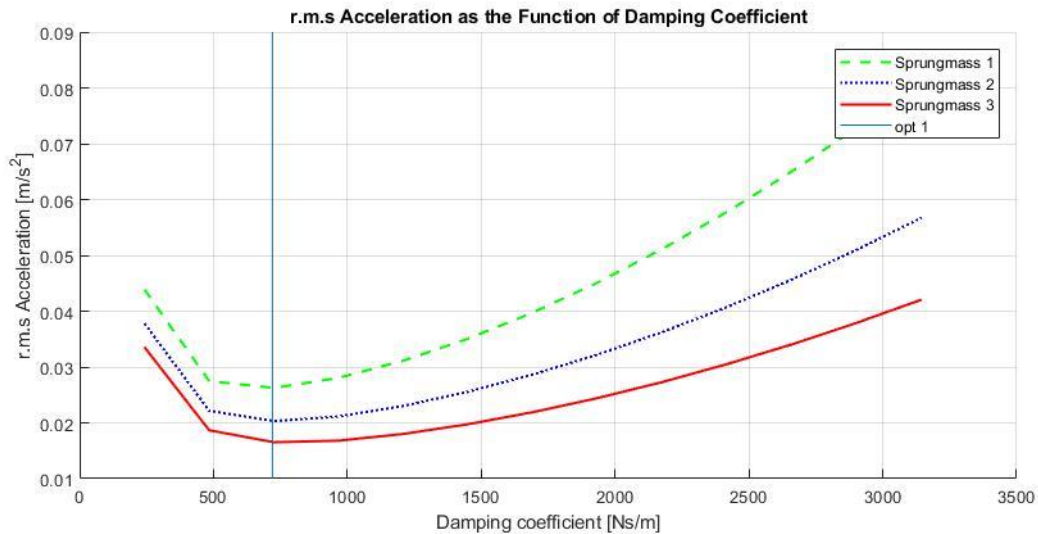

Figure 5. Case C result

The most prominent point of the case C is that the value of optimum damping coefficient does not change for the conditions of three variations of unsprung mass. Figure 5 compares three calculation results of the case C. The optimum damping coefficient relies on 720 Ns/m of damping coefficient for the three selected unsprung masses. However, those yield in three different values of r.m.s acceleration which are 0.026 m/s², 0.021 m/s², and 0.016 m/s² for the value of unsprung mass 45 kg, 55 kg, and 65 kg respectively.

Further observation on the graph, after achieving the optimum value of damping coefficient, for the increase of this value, the root-mean-square acceleration also increase with slight parabolic behaviour. Comparing three results, by lowering the unsprung mass, the curve is getting more incisive as opposed to the other two curves. Thus, it can be said the lighter unsprung mass, with the constant value of sprung mass, will give higher increment of the vertical acceleration perceived by occupants. On the other hand, the heavier the unsprung mass give slight increment of the r.m.s acceleration. Observing the smaller value of the damping than the optimum one, the three values give the significant increase of the vertical r.m.s value of acceleration as the chosen value of damping is lower. The same behaviour occurs for the values greater than the optimum damping.

4. Conclusion

Varying the sprung mass and unsprung mass, under the assumption that the unsprung mass is 10% of chosen value of sprung masses, increases the value of the optimum damping coefficient by approximately 131.5 Ns/m in average for each increment of sprung mass. However, this condition does not affect in the r.m.s acceleration perceived by occupants and the value keeps constant at 0.02 m/s². For the case of fixed unsprung mass, three different sprung masses contribute to the increment of both r.m.s acceleration and the optimum damping coefficient. The increment of r.m.s value is in the order of 0.005 m/s², while for the optimum damping coefficient values also increase by 132 Ns/m in each increment of sprung masses. Furthermore, when sprung mass is constant, it does not influence the value of the most optimum damping coefficient which is in the value of 720 Ns/m for all three applied unsprung masses. Yet, it is clear that it affects the r.m.s acceleration value by 0.005 m/s² at the point in which the optimum damping coefficient is achieved. Finally, varying the sprung masses with the proportional value of unsprung masses does not affect the r.m.s acceleration, fixing the unsprung mass affects both the optimum damping coefficient and r.m.s value and making the sprung mass constant, the optimum value of damping coefficient does not change. Further studies are planned to experimentally compare the present study with the model of full degree of freedom taking into

consideration the weight distribution of the vehicle. In terms of occupant comfort, modelling the source of the internal source excitation could be also interested.

5. Acknowledgments

Very great appreciation is expressed to *Lembaga Pengelola Dana Pendidikan* for the entire funding of the study and explanation given by Prof. Andrea Tonoli has been a great help and profound support in conducting this project. Further, my special thanks are extended to Politecnico di Torino, Diponegoro University, Gadjah Mada University, and Yogyakarta State University for complete support and collaboration of this work.

6. References

- [1] X M Sun, Y Chu, J Fan and Q Yang 2012 Research of Simulation on the Effect of Suspension Damping on Vehicle Ride *Energy Procedia* **17** p 145 – 151
- [2] M M Moheyeldin, A M Abd-el-tawwab, K A A El-gwwad and M M M Salem 2018 An Analytical Study of the Performance Indices of Air Spring Suspensions over the Passive Suspension **Journal of Basic and Applied Sciences** press
- [3] E Sert, P Boyraz 2017 Optimization of Suspension System and Sensitivity Analysis for Improvement of Stability in A Midsize Heavy Vehicle Engineering *Science and Technology International Journal* **20** p 997-1012
- [4] V Barethiye, G Pohit, A Mitra 2017 A Combined Nonlinear and Hysteresis Model of Shock Absorber for Quarter Car Simulation on the Basis of Experimental Data *Engineering Science and Technology International Journal* **20** p 1610-1622
- [5] A E Geweda, M A El-Gohary, A M El-Nabawi, T Awad 2017 Improvement of Vehicle Ride Comfort Using Genetic Algorithm Optimization and PI Controller *Alexandria Engineering Journal* **56** p 405-414
- [6] Y Yang, W Ren, L Chen, M Jiang, Y Yang 2009 Study on Ride Comfort of Tractor with Tandem Suspension Based On Multi-body System Dynamics *Applied Mathematical Modelling Journal* **33** p 11-33
- [7] G Genta and L Morello 2009 *The Automotive Chassis Volume 2: System Design* (New York: Springer)
- [8] L Morello, L R Rossini, G Pia, and A Tonoli 2011 *The Automotive Body Volume 2: System Design* (New York: Springer)