

SPRAYBOOTH

Paint Special Course

" THE MONEY MACHINE "

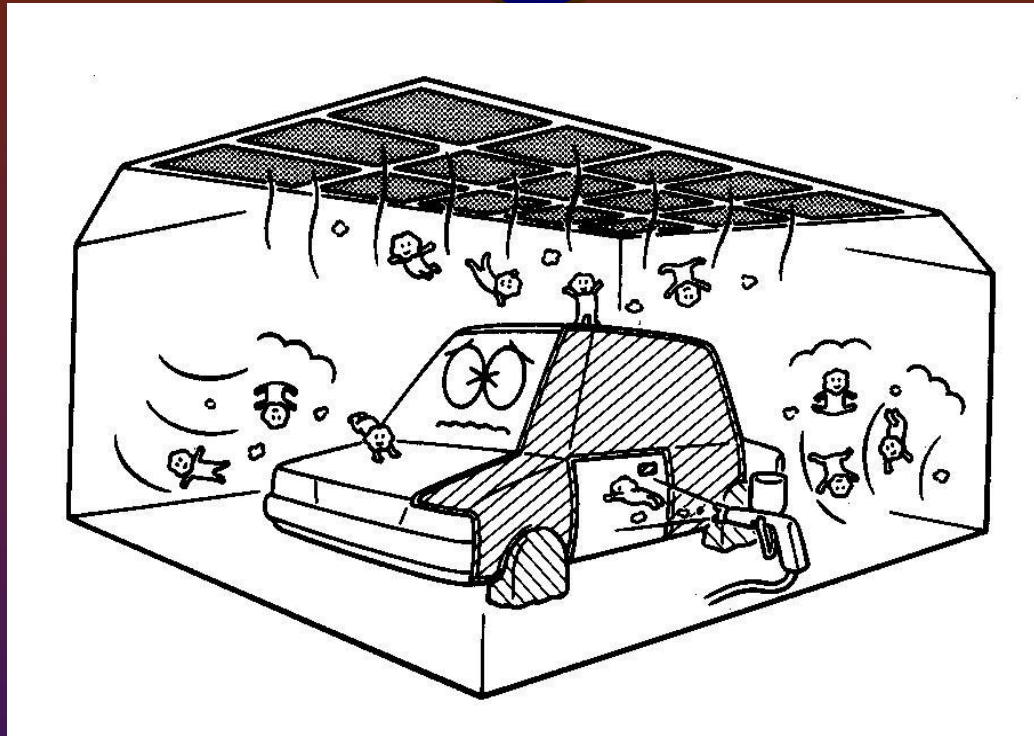

❖ Spraybooth :

Sebuah ruang tertutup tempat aplikasi pengecatan yang menggunakan sistem sirkulasi udara tersaring untuk menjaga agar udara yang masuk dan keluar ruang tersebut bersih

Tipe Spraybooth



Single Blower

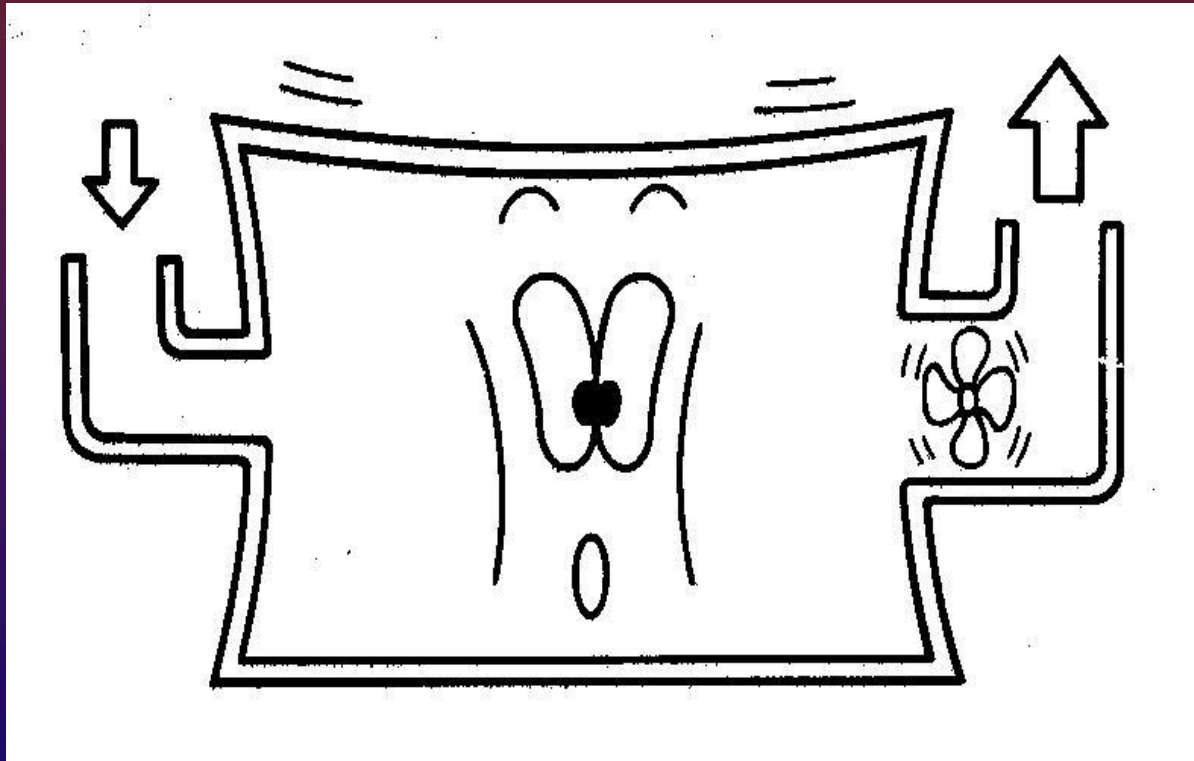

Double Blower

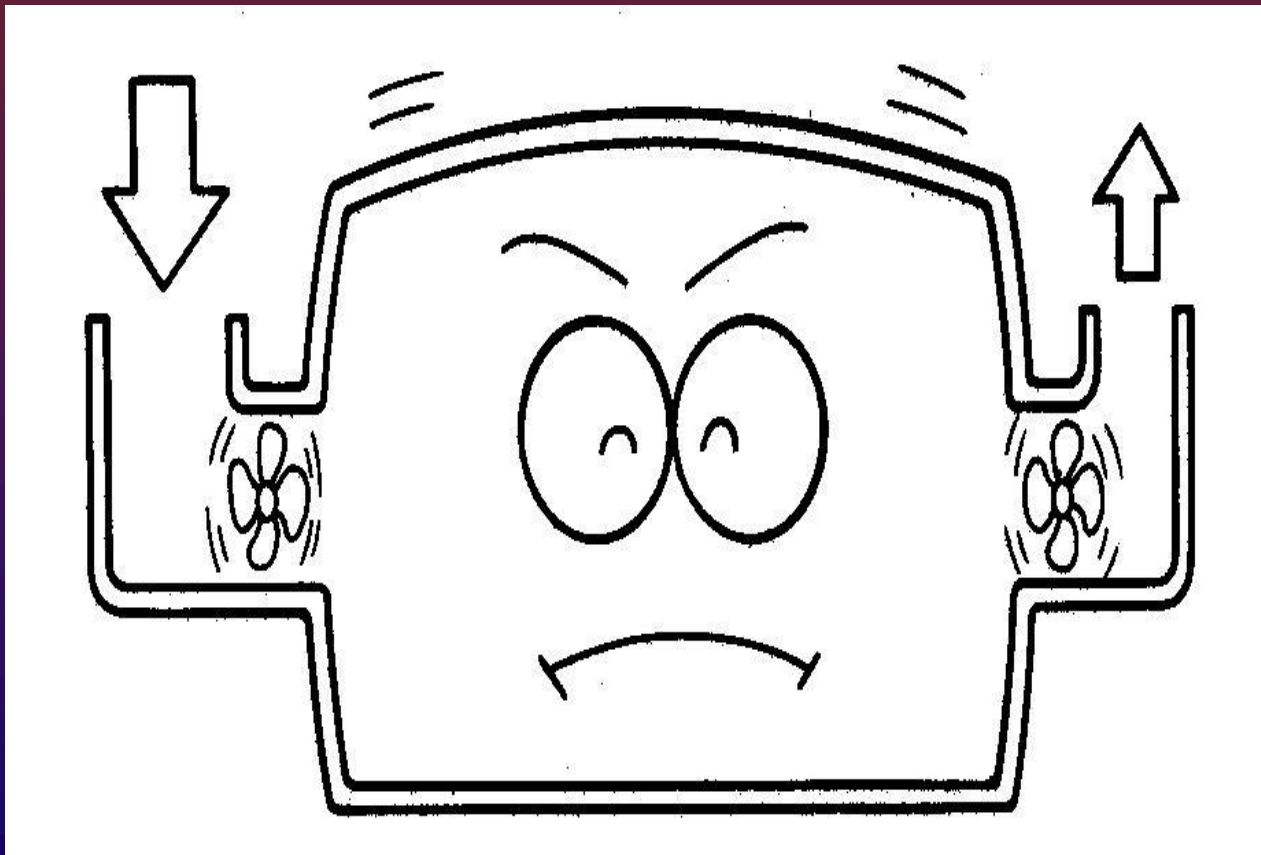

COMBIBOOTH

Spraybooth yang dilengkapi dengan fasilitas pemanas untuk proses pengeringan cat (Oven)

- ❖ Saima
- ❖ Saico
- ❖ Lutro
- ❖ Usi
- ❖ Blowtherm

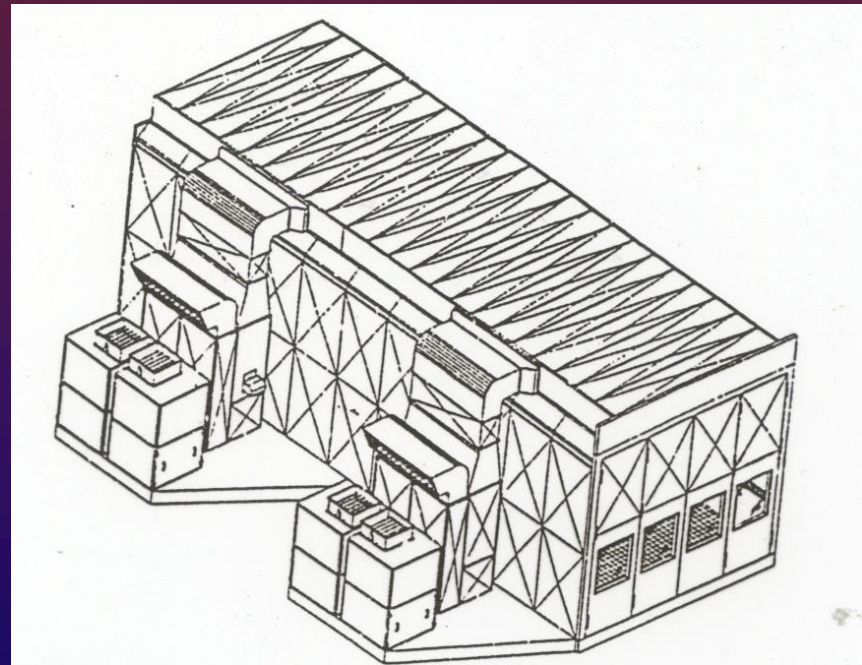

Cara kerja Spraybooth

□ Fase pengecatan

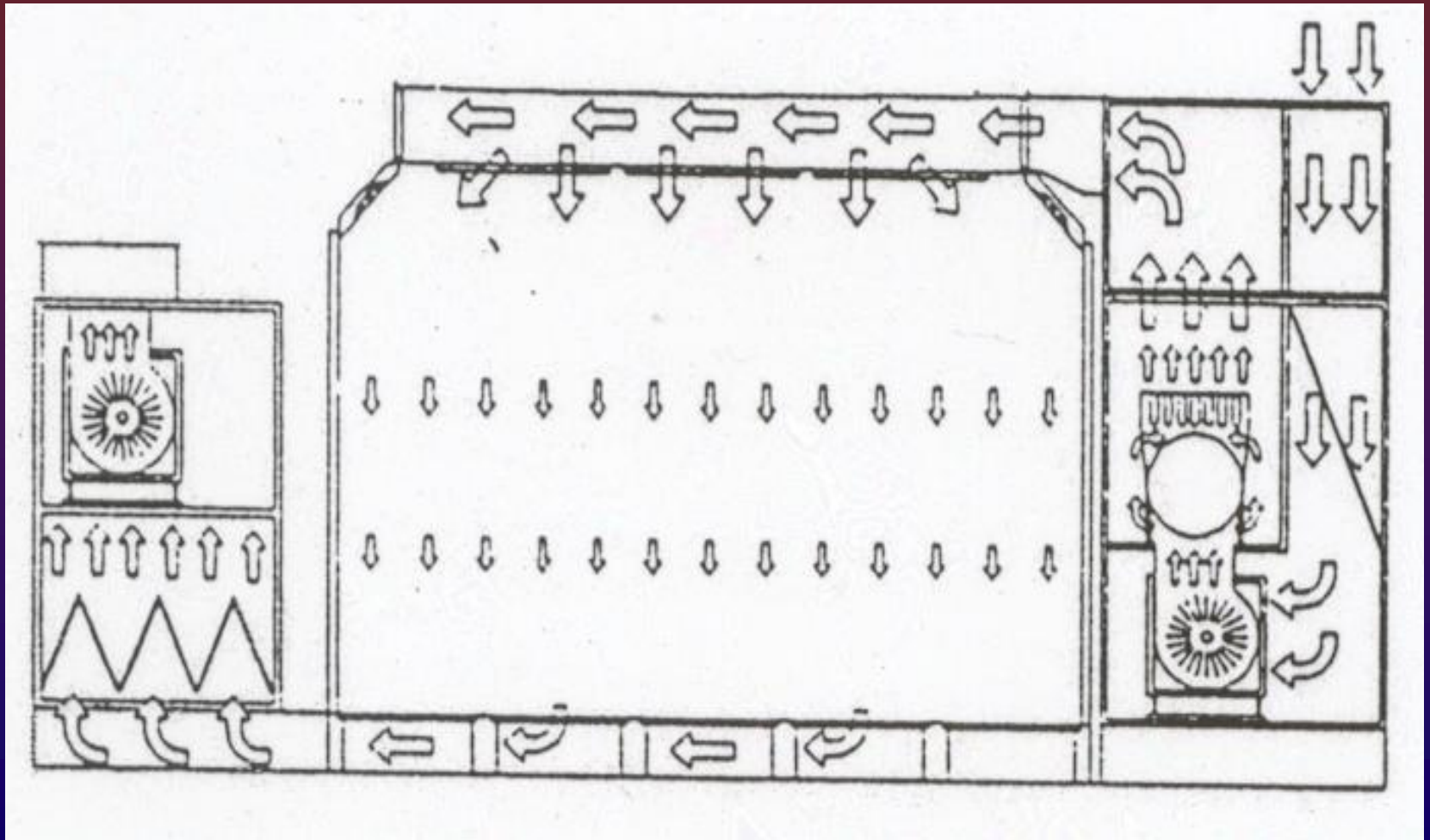

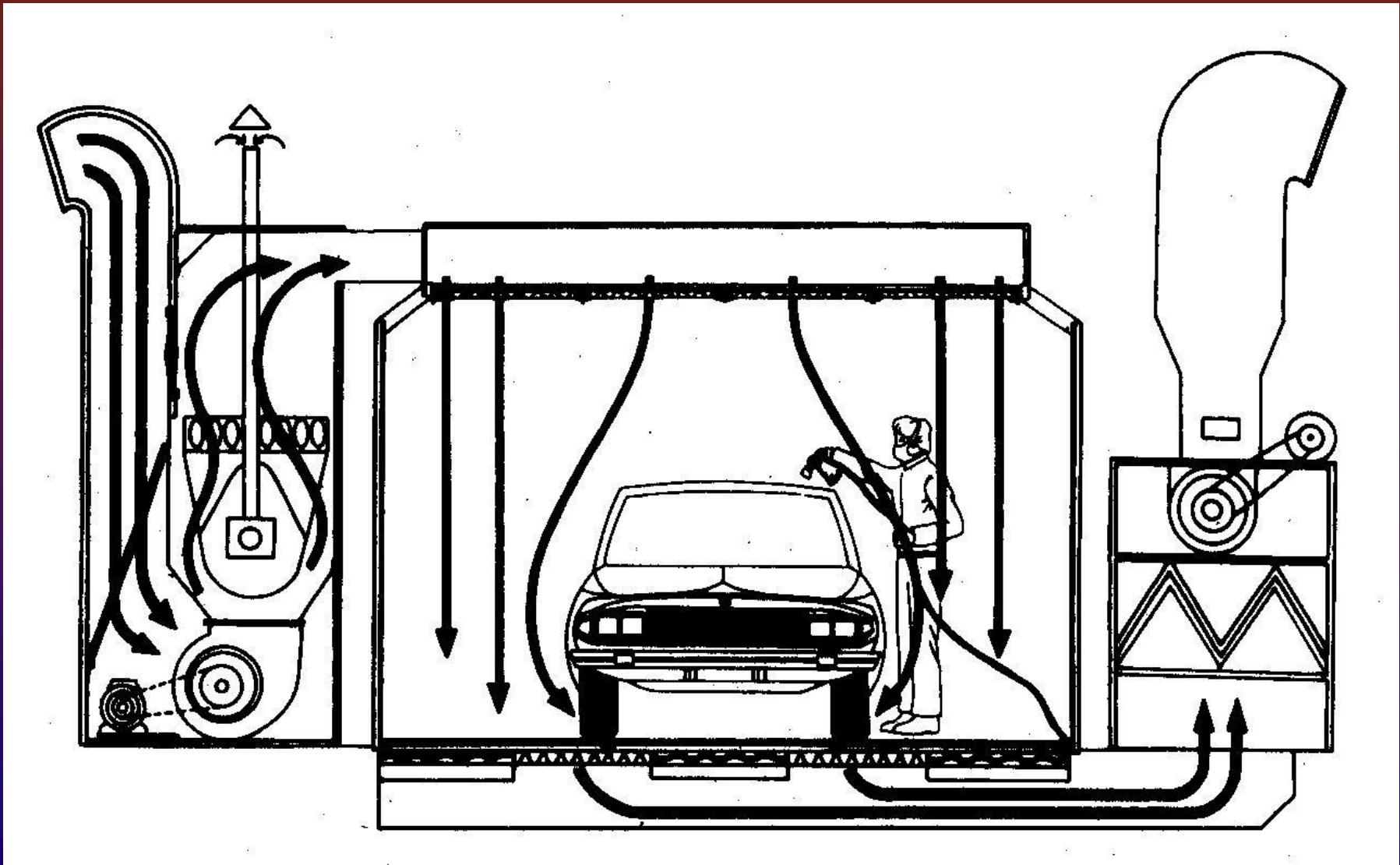
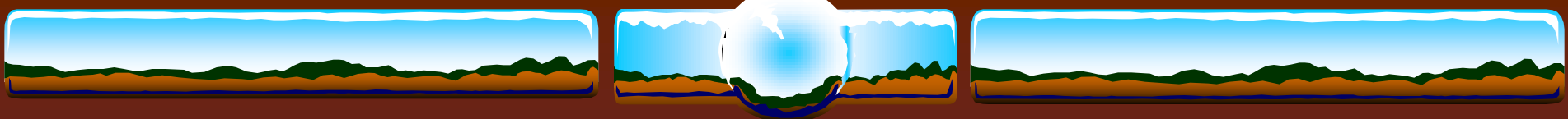

□ Fase pengeringan

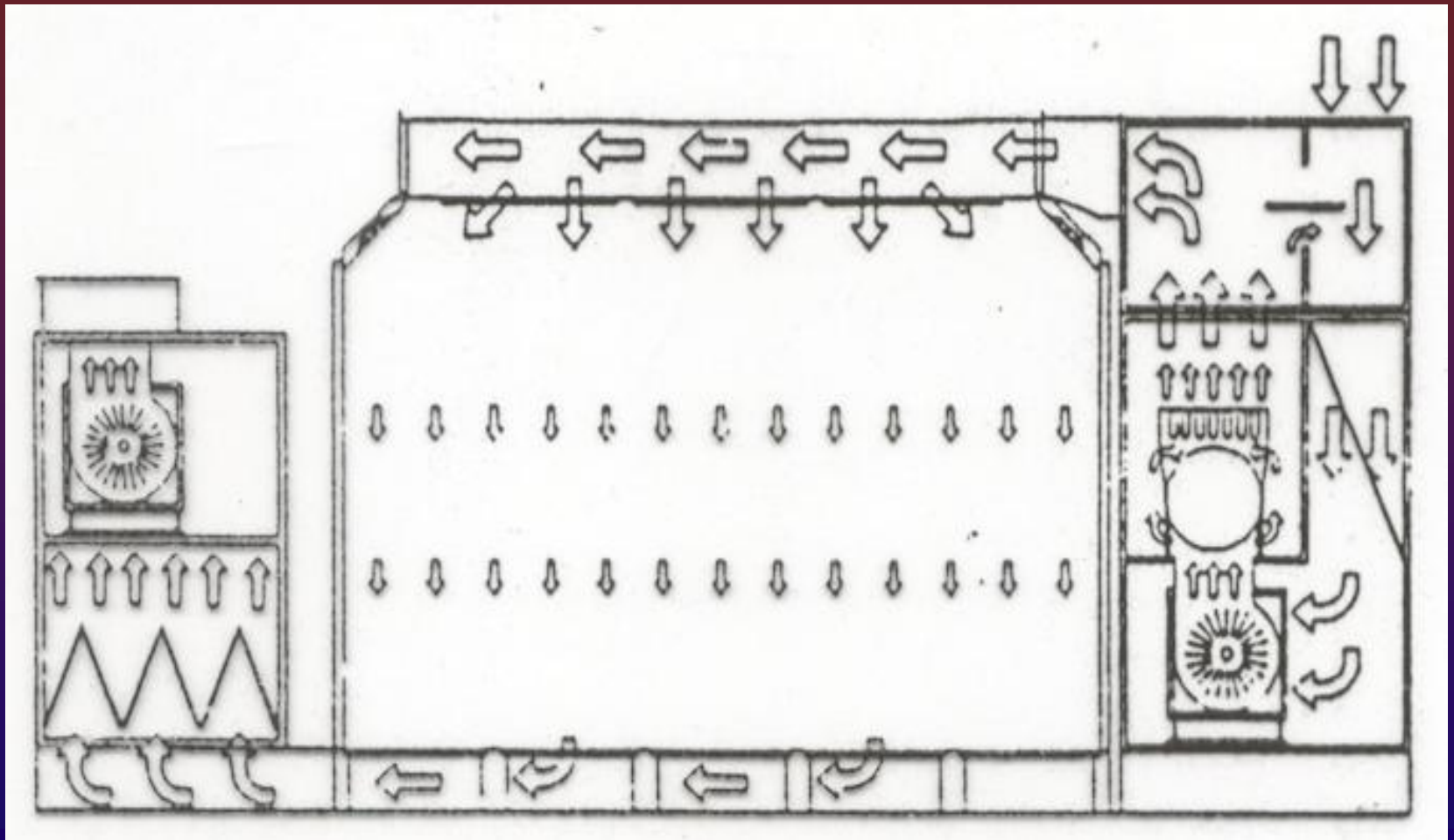

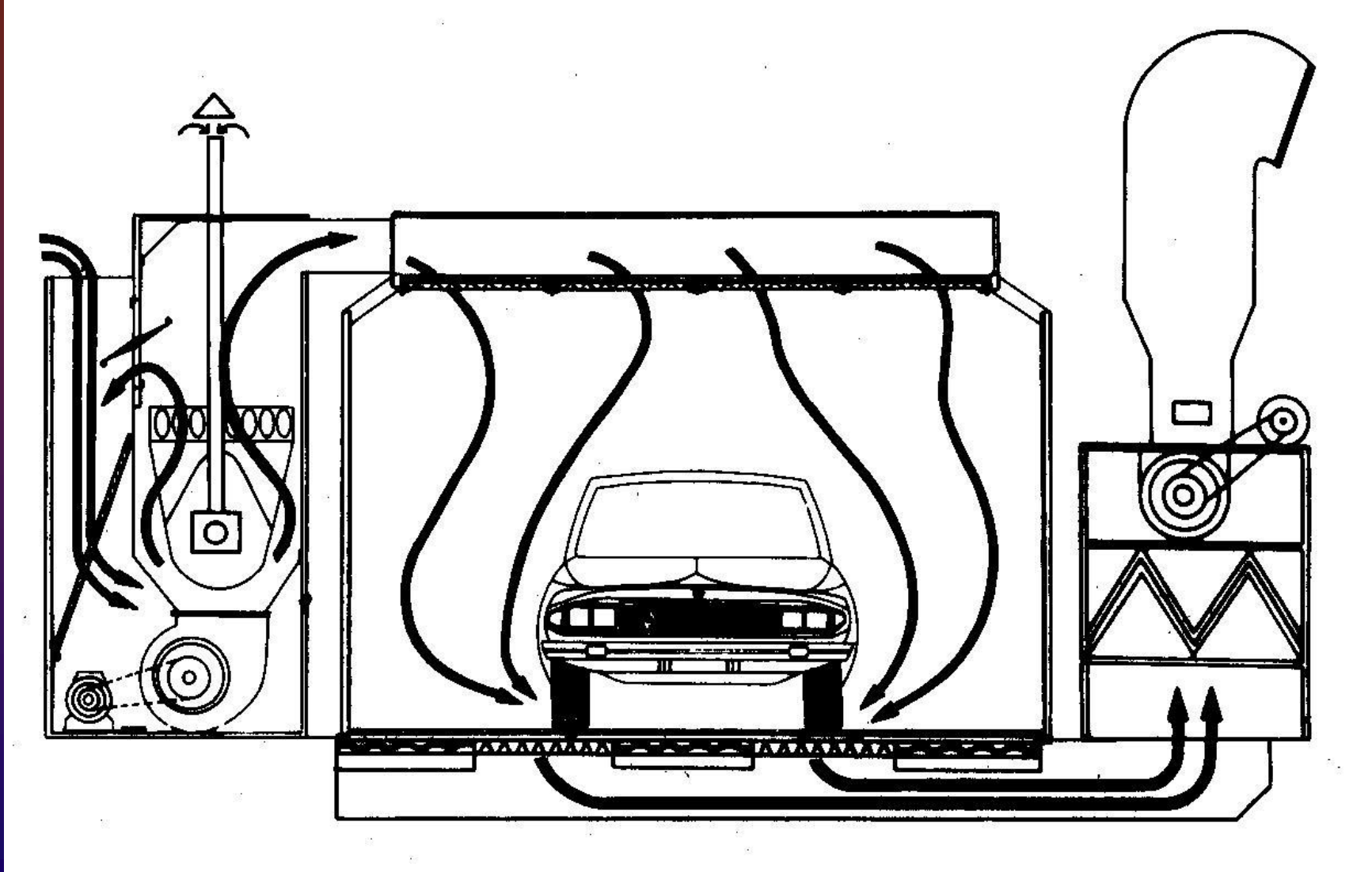
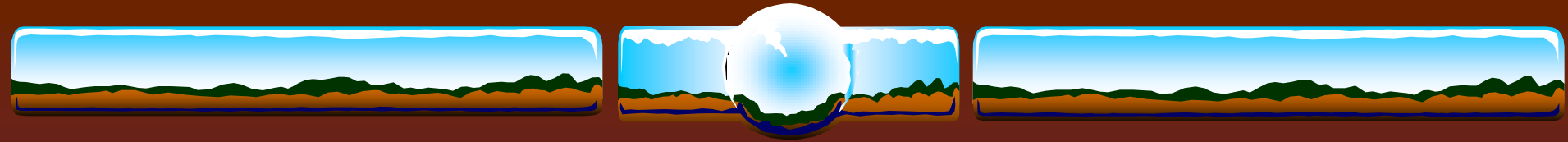

Grafik pengeringan pada oven

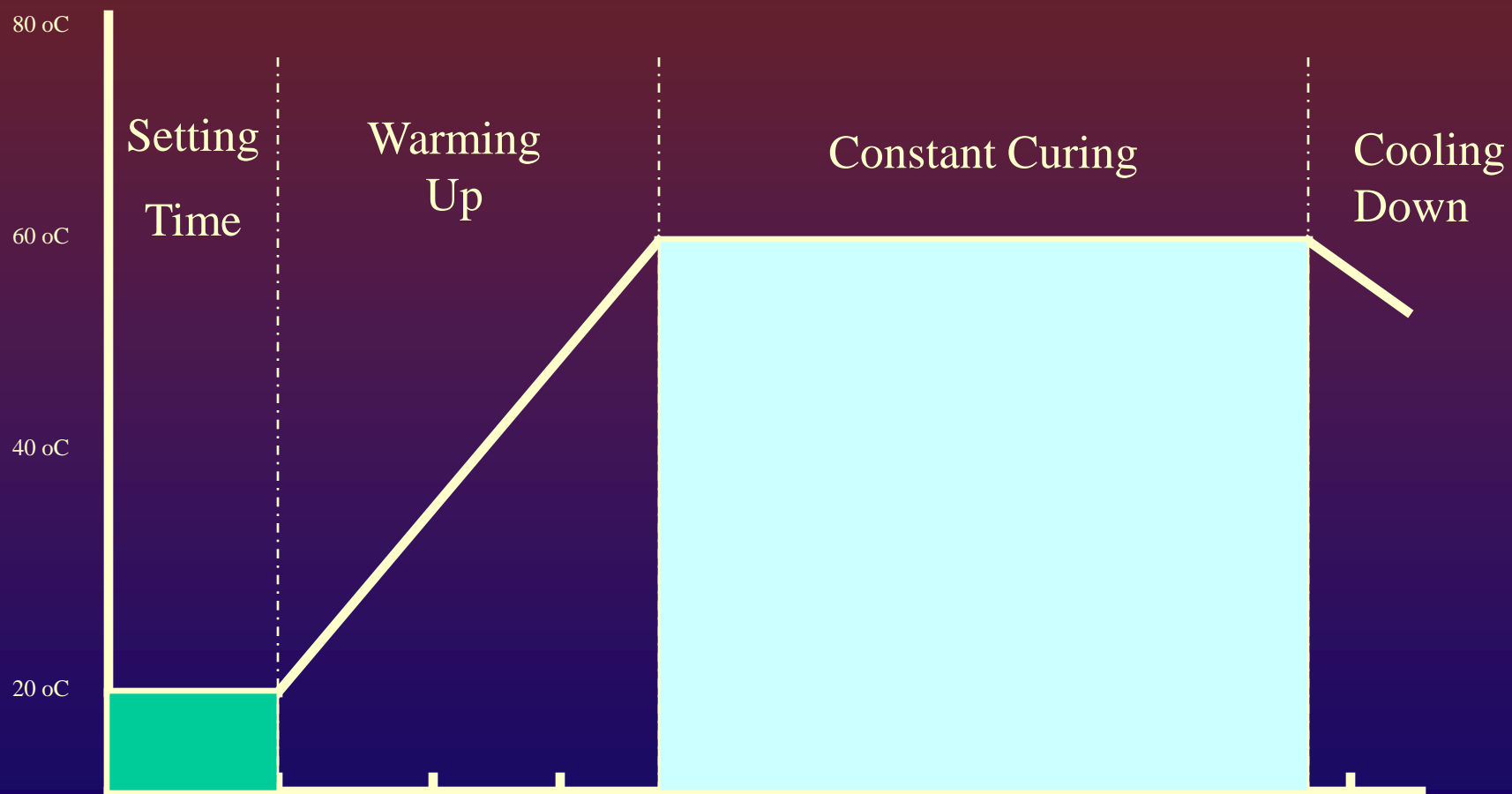

Komponen Booth

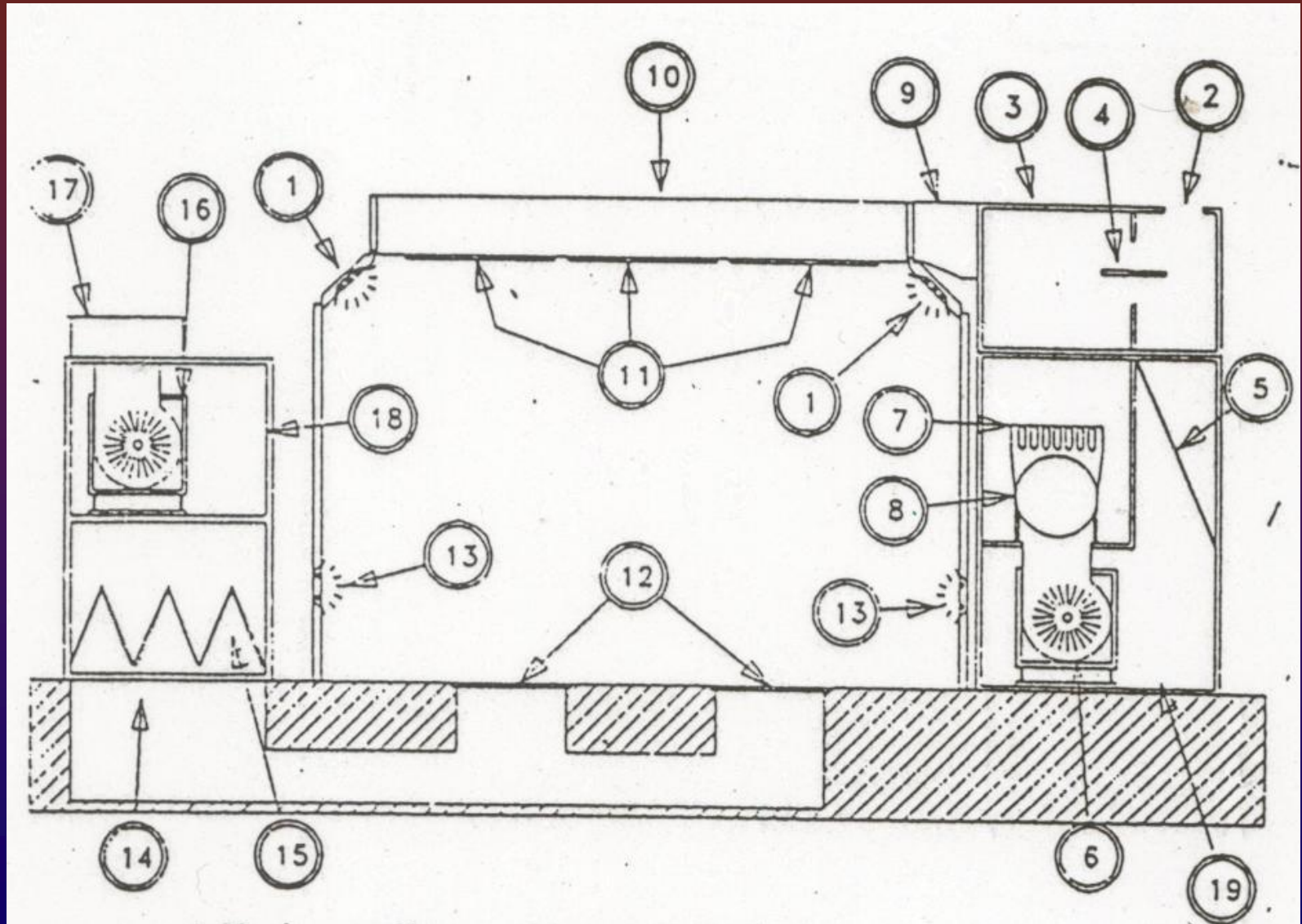

Hot Air Generator Group

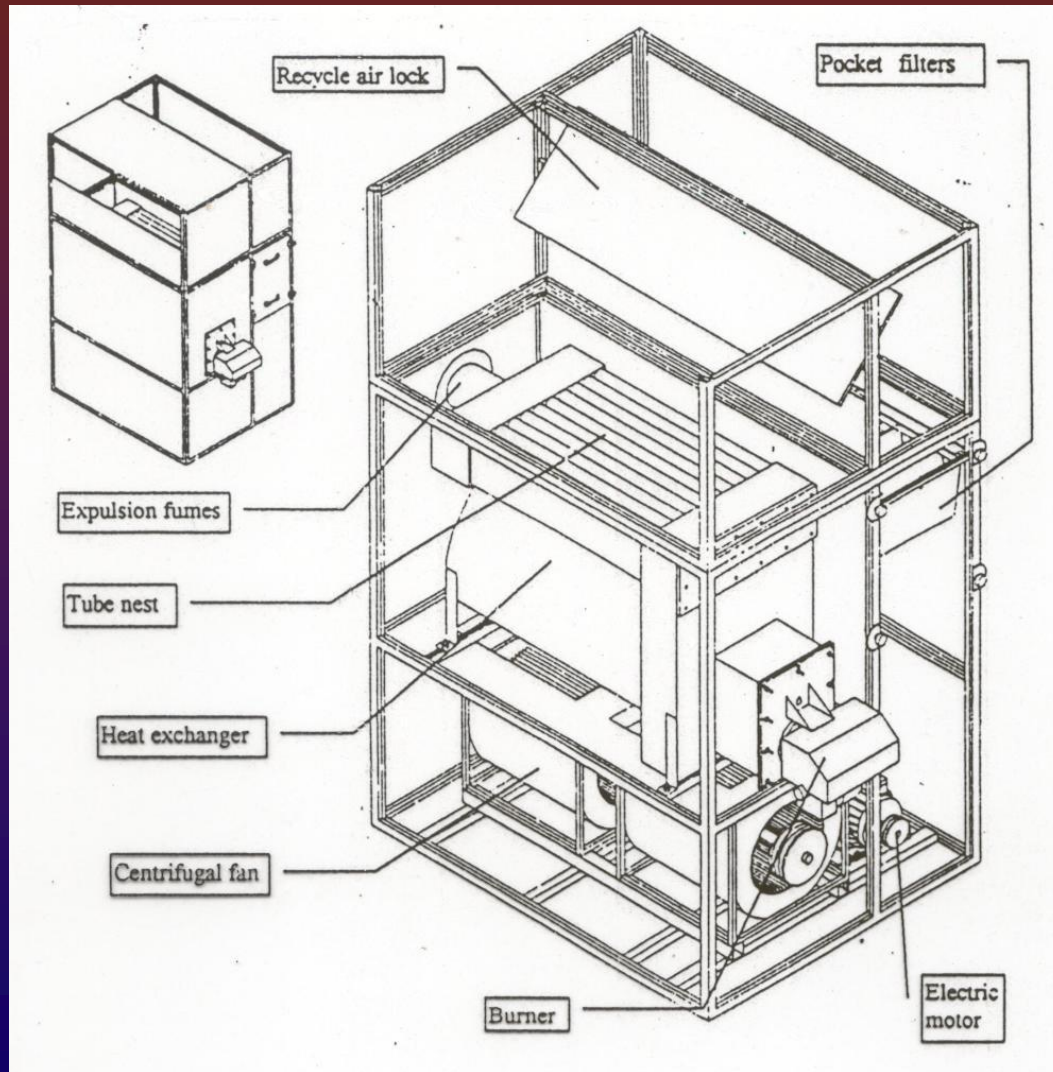

Cleaner / Extractor

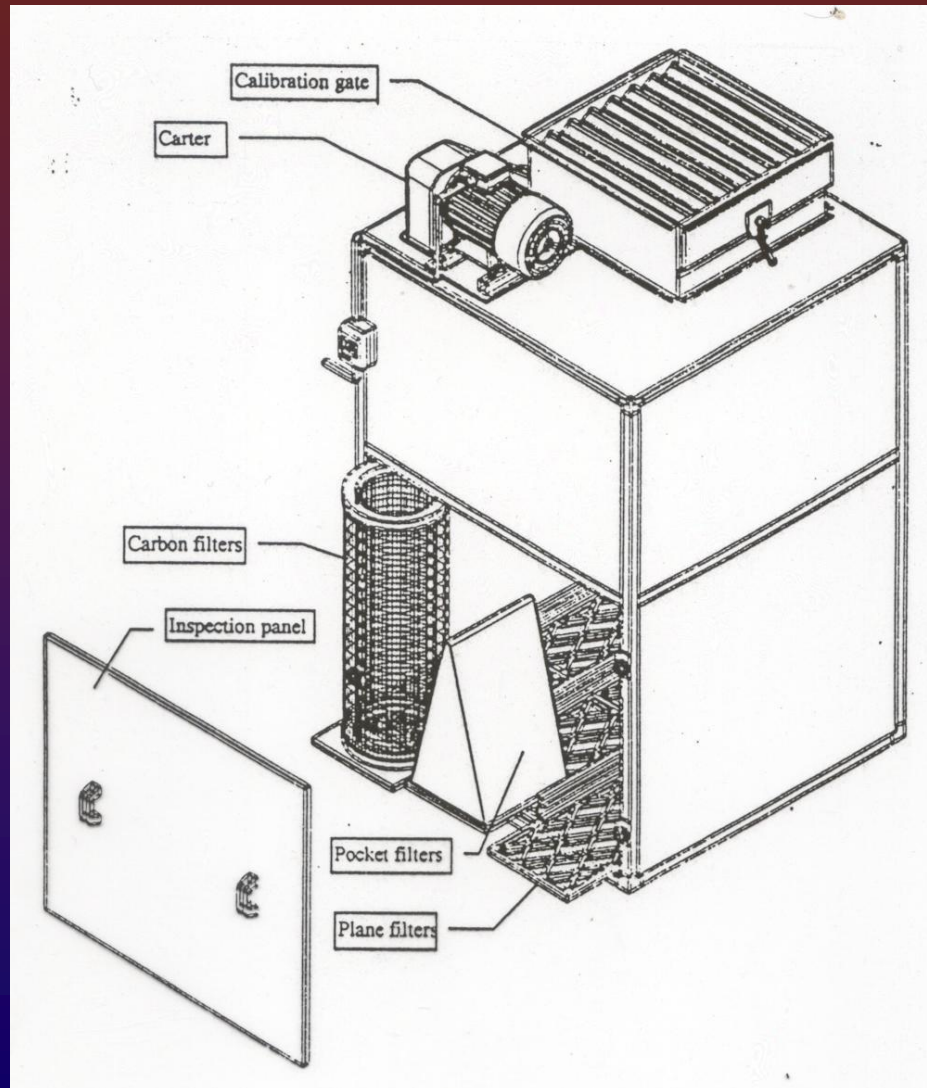

Control Board

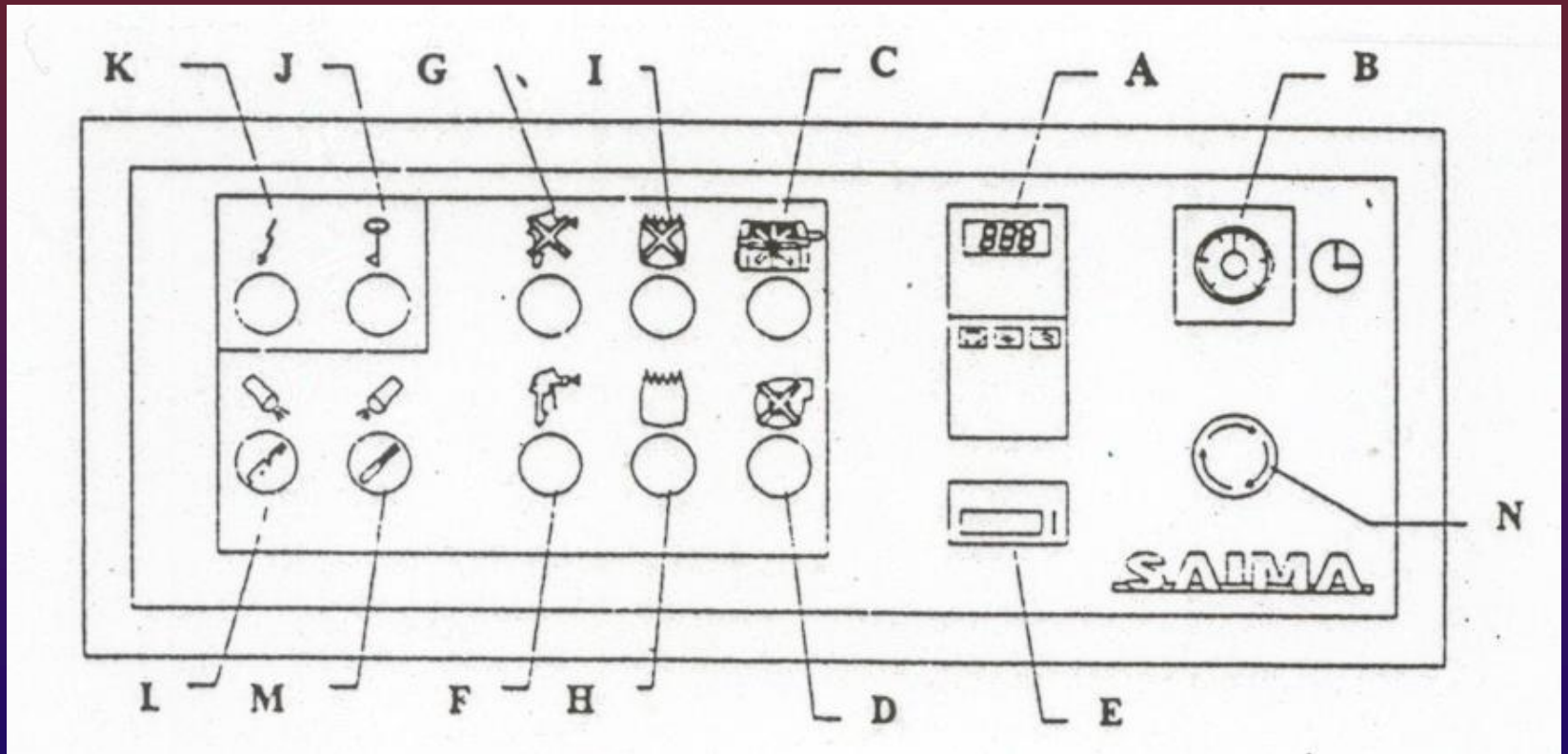

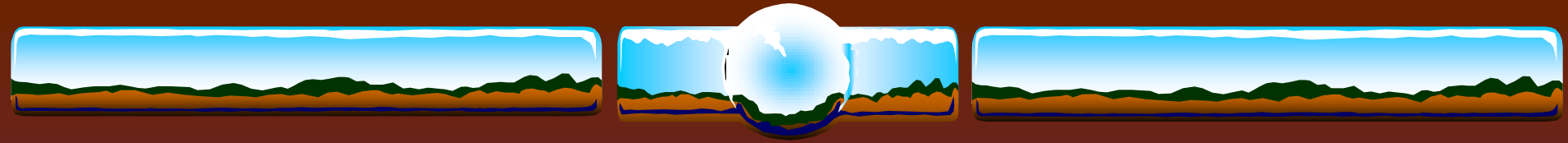

Perawatan Berkala

Saringan Bawah (undergrating filter)

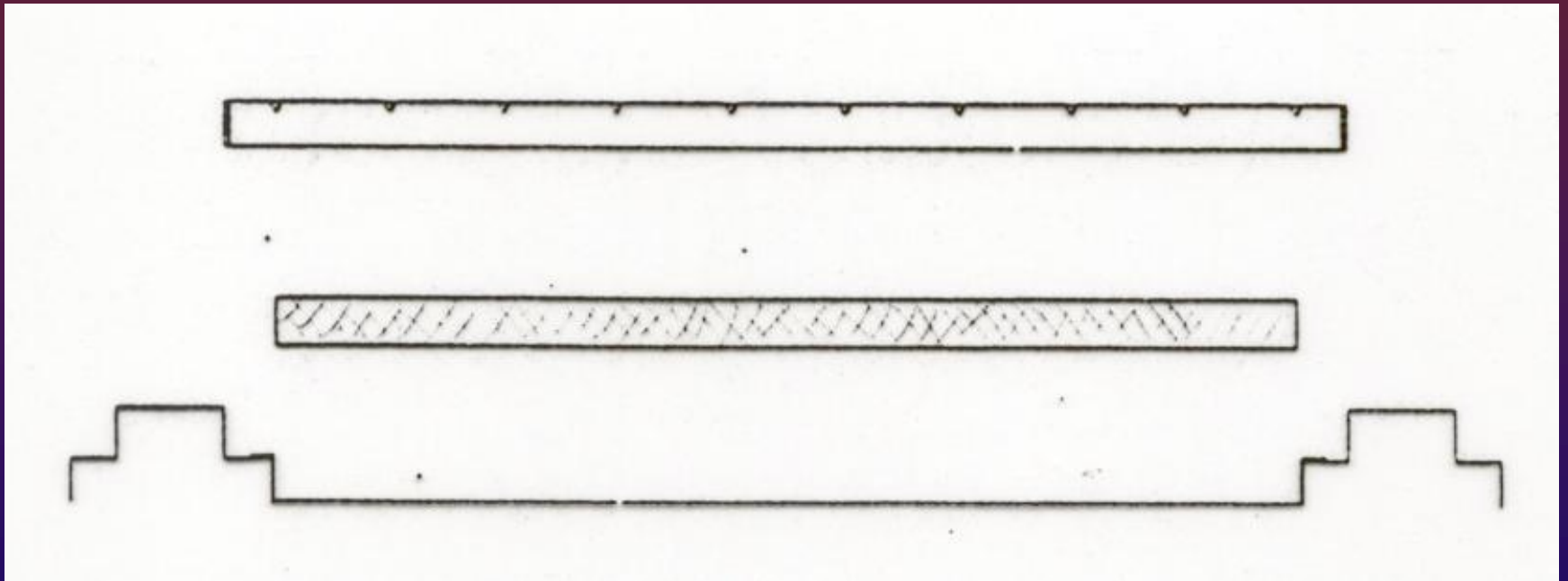

Generator Pre-filter

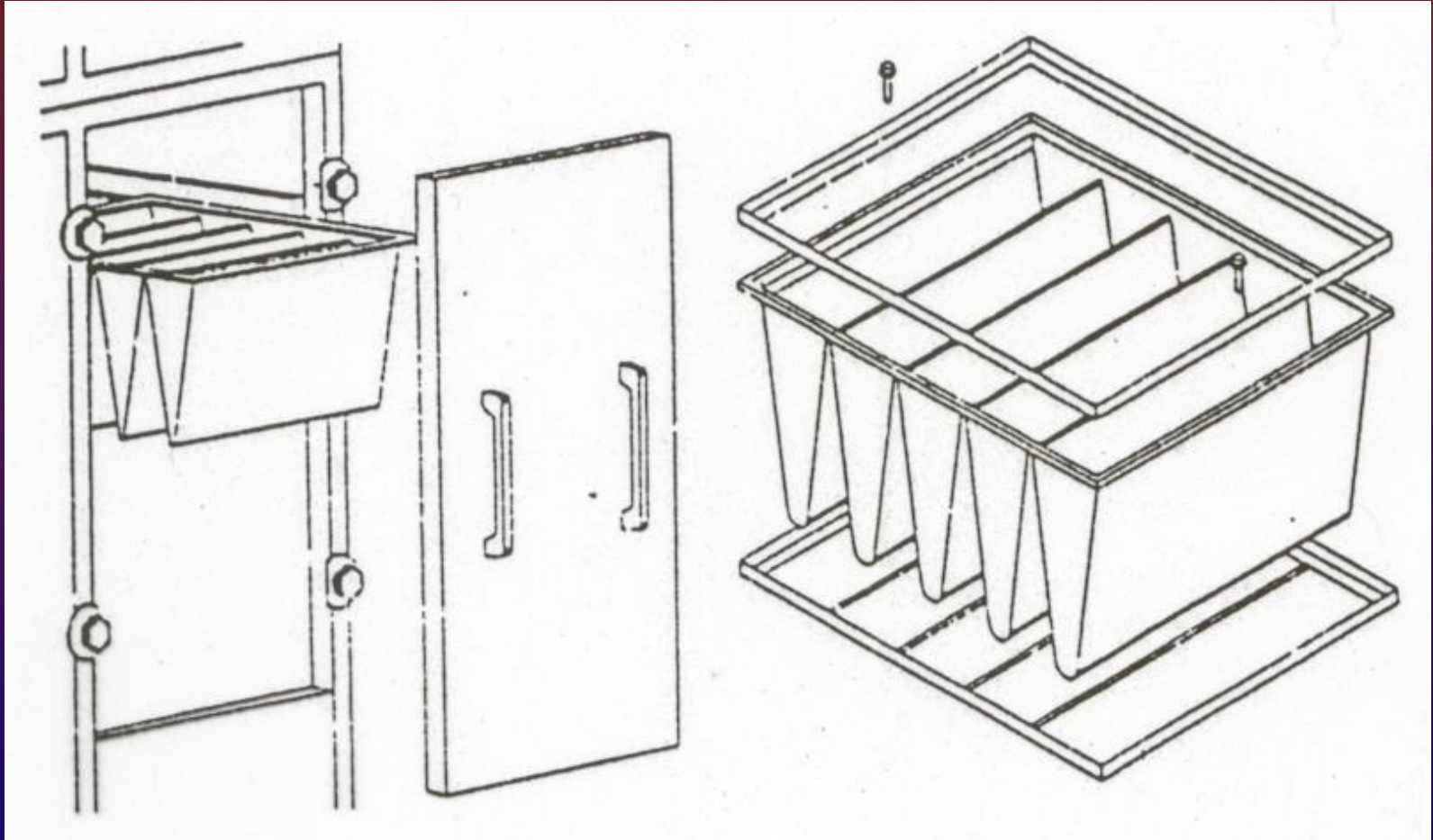

Saringan Atap (Ceiling Filter)

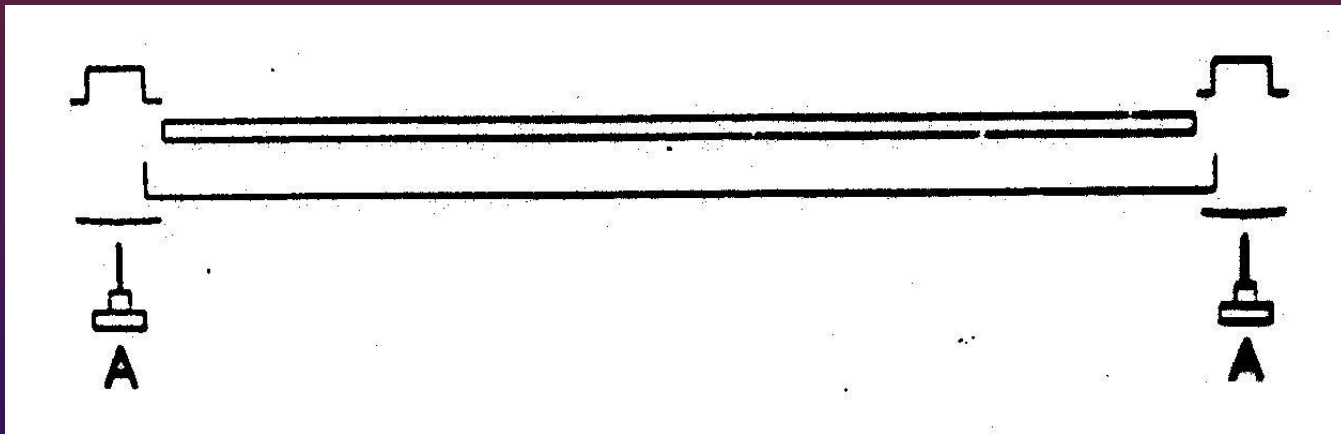

Fume Stack & Driving Belt

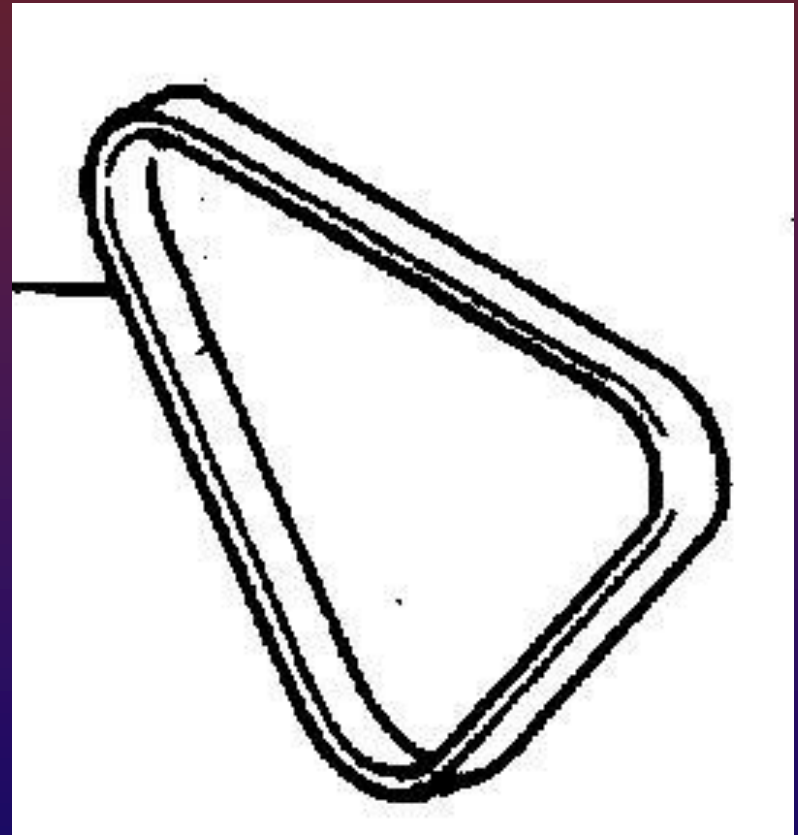
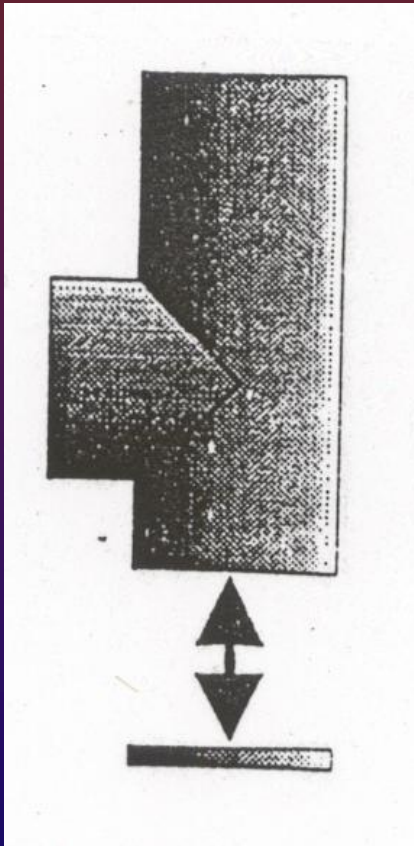

Fluorescent – Neon Lamps

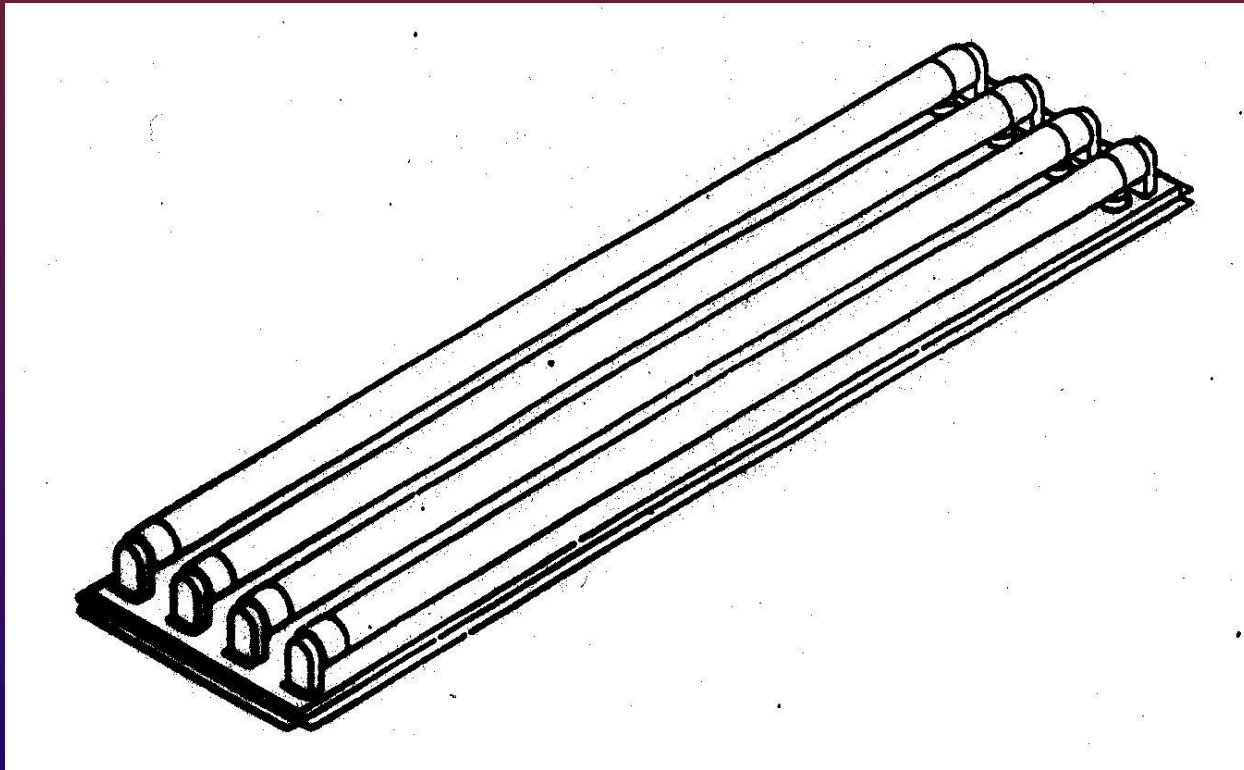

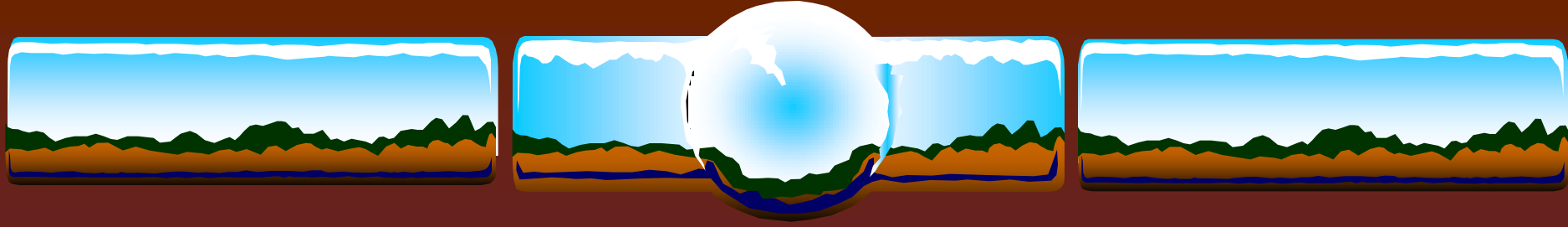

Alat Pengerian Lain

Infra Red



Model Infra Red

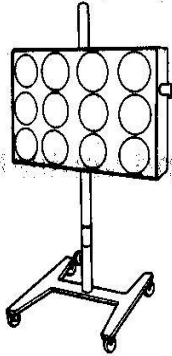

Small Bank Stand Type

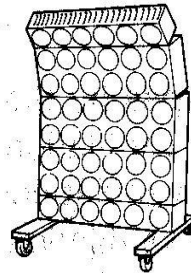

Large Bank Stand Type

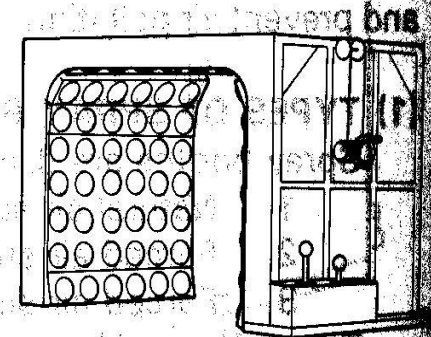

Tunnel Type

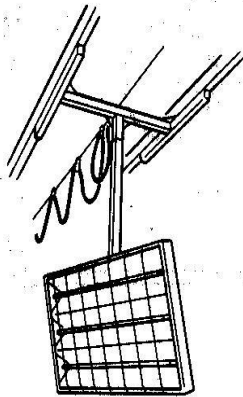

Rod Heater (Hanging Type)

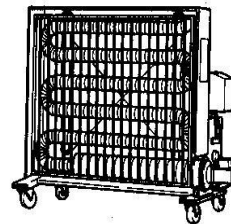

Tubular Type

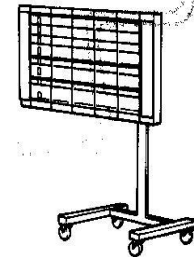
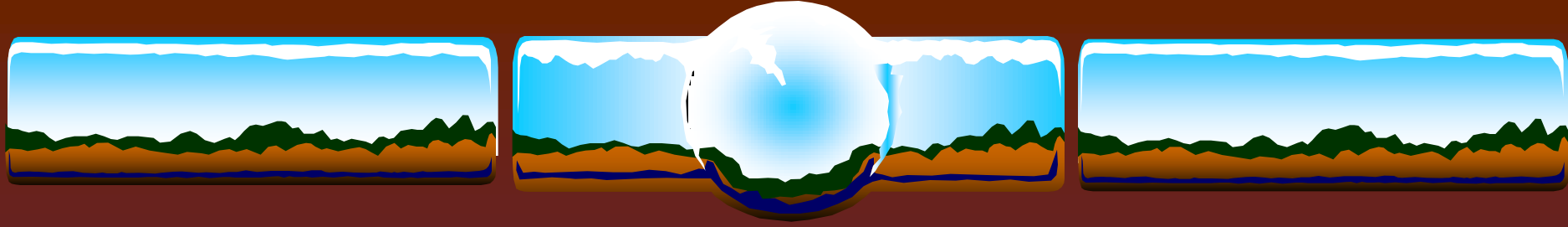

Plate Type



Cacat pengecatan yang
mungkin terjadi bila
dilakukan di dalam
Combibooth



Solven Pop (popping)



Seeds (Bintik-bintik)





Orange Peel





Pertanyaan

Mana yang lebih baik dalam pengeringan cat :

- menggunakan oven
- tidak menggunakan oven



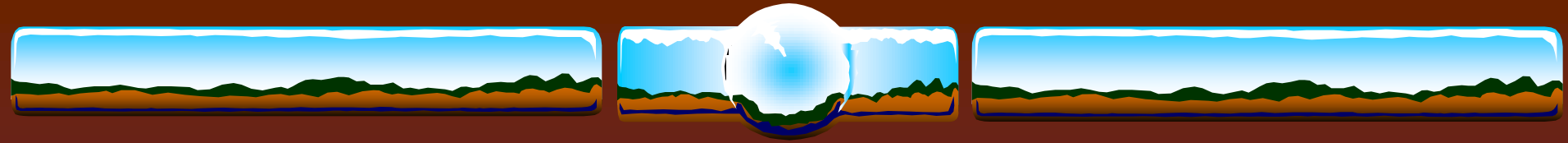

SEKIAN